

The new Menzi Muck M5-series.

Technical description.

Engine

4-cyl. Turbo Diesel-Engine / Commonrail
Deutz TCD 4.1 L4
Exhaust stage EU 97/98 IIIB (TIER 4 interim)
integrated particle filter/catalyst (without additive)
max. output 115 kW (157 HP) according to SAE J1995 / ISO 3046
adjusted performance according to ISO 14396: = 114 kW (155 HP) at 2000 min-1
Maximum torque at 1600 min-1: 610 Nm
Capacity 4100 ccm
Service interval 500 hours

Cooling

Generously dimensioned cooling system (pull).
Three separate coordinated cooler elements for hydraulic oil/ charge air/ water maximum cooling capacity through side-by-side arrangement of the cooling elements
Variable fan motor
optional: swing condenser-element for air-conditioning

Hydraulic system

Sensitive LUDV Load Sensing hydraulic system
Two capacity controlled swash plate axial piston pumps (P1/P2)
Optional: third controlled swash plate axial piston pump (P3)
Gear pump for fan drive
Operating pressure 300 bar/4351 psi
Capacities of the hydraulic pumps:
P1 = 280 l/min/ 73,96 US-gall. for working (working pressure: 300 bar/4351 psi)
P2 = 175 l/min. / 46,23 US-gall.for driving (working pressure 400 bar/5802 psi)
P3= 190 l/min. / 50,19 US-gall. for powerline M5 (optional)
(working pressure 350 bar/5076 psi)

Hydraulic cylinder

The hydraulic cylinders are again from our own design and manufacturing
Cylinders on the chassis are equipped with check valves (safety hose break)
All cylinders on the boom assembly are equipped with cushioning

Hydraulic circuits

Circuit 1 (on the boom assembly): up to 190 l/min. / 50,19 US-gall. through proportional foot pedal- double acting
Circuit 2 (on the boom assembly): up to 100 l/min./26.4 US-gall. through proportional-rocker switch on the right joystick – double acting
Circuit 3 (on the boom assembly): up to 40 l/min./10.6 US-gall. through switch on the left joystick - double acting (optional)
Circuit 4 (on the boom assembly): for hydraulic quick hitch from pilot pressure – double acting (optional)
Hydraulic preparation for winch (on the chassis): up to 120 l/min./31.7 US-gall. through proportional rocker switch on the left joystick – double acting (optional)
Return line (on the boom assembly): for hydraulic hammer
Leakage line (optional)
The required liters/US-gallons of the auxiliary hydraulic circuits can be selected over the colored display.

Powerline M5 (optional)

The powerline M5 is recommended for accessories, which demand a permanent specific high power output:
As for example Mowers, harvester heads, drill rigs or stumpgrinders
The option Powerline is composed as follows:
1 separate hydraulic pump (P3) with priority supply up to 190 l/min. / 50,19 US-gall. simple acting circuit
1 large hydraulic hose to the arm for pressure and return
Pressure up to max. 350 bar/5076 psi, quantity of liters up to max. 190 l/min. / 50,19 US-gall. can be selected over the display
Double acting circuit (optional)

Electrical system

Voltage 24 volts
Starter 7.2 kW
Alternator 100 Amp
Total electrical power 2400 Watt

Rotation / Swivelling

Swivelling with momentary steering over the joysticks for proportional and demand control
Double supported slewing ring
Slewing ring, size modul 10
Maximum slewable speed up to 10 rpm
Axial pinion constant engine with high starting torque, integrated valves with ramp time for soft approaching and deceleration of the swing
Automatic acting disc brake
Swivelling radius 360° endless
Maximum swivelling moment 52'000 Nm

Drive M5-Serie

Hydrostatic drive in closed circuit
Separate Hydraulic pump – capacity 175 l/min./46.2 US-gall.; max. 400 bar/5802 psi
Two stage travelling gear (according to type and tires up to max. 15 km/h/9.32 mph)
Automatic parking brake
Automotive drive: Through the foot pedal the engine speed and drive are driven synchronously. Within both speed steps the foot pedal can be adjusted in a finer resolution by a pushbutton.

Drive M540 & M545

All wheel drive Menzi H-Drive-System with torque overlay for maximum power conversion regarding traction / transmission
Menzi Raod Traction Modul (RTM) switchable barrier for maximum drive or modus for maximum floor / tire-conserving

Tires big wheels

Quality forestry Nokian tires 600/50-22,5 with steel inserts (b=600 mm, d=1140 mm)
Optional: Quality forestry tires Nokian 600/55-26,5 with steel inserts (b=600 mm, d= 1350 mm)
other tires on inquiry

Tank contents

Operating tank: 205 liters / 54.2 US-gall.
Additional fuel tank in the chassis: 230 liters / 60.8 US-gall.
Hydraulic oil system content: 220 liters / 58.1 US-gall.

Steel construction

Beside our know-how as years of market and technology leader all supported steelwork are statically charged per FEM (Finite-Elemente-Method) All moving parts are equipped with wear bushings.

Chassis / support

Proven construction with years of experience
Swivel feet in front are of unstressed steel casting
Construction with maximum ground clearance
Relevant moving parts are equipped with wear bushings

Operation /Steering

Ergonomic multi function lever Menzi ultijystick with each two proportional rockers (with palmrest)
Standard equipped with three foot pedals (drive, telescope and auxiliary circuit)
Fourth foot pedal for winch (optional)
Various toggle switches

Menzi Powerboom

Patented boom
No collision danger with boom cylinder
Minimal turning radius through new arm concept
Menzi wide angle for maximum working area
Design allows close range operations
Hydraulic telescope 1800 mm
Telescope supported by 8 wear plates (front and back on all four sides)
Maximum lift capacity / larger cylinder diameter
Bucket pin diameter 60 mm

Panorama-Cockpit

Spacious and clear panorama-security-cockpit with „Roll-Over-Protection-Security“ – ROPS according to (DIN ISO 3471)
Vibration free and quiet cabin through hydromounts
Cabin can be tilted with a hydraulic hand pump
Optimal view on all sides
View up by rounded and bent far back windscreen

Front and right side window hinged
Air cushioned seat type „Klepp“
Radio with CD-Player, inclusive two speakers.
Storage compartments, document compartment, bottle holder, cubbyholes, socket for charging mobil phones, coat hook etc.
8 spotlights standard
(4 in the front / 4 in the back)
Powerful heating with seven individual adjustable air nuzzles
Standard equipped with pollen and recirculated air filter
Powerful air-conditioning with automatic climate control (optional)
Air-cushioned comfort seat type Grammer (optional)

Dashboard with LCD-Display

Clear and ergonomic arranged instrument panel
Analog controls with integrated color display to show the most important indicators: engine speed, hourmeter, day time counter, fuel gauge, dirty air filter, hydraulic oil temperature, water temperature, battery state of charge, engine oil pressure, pressure hydraulic return filter, alarm, service display, engine stop etc.
various control elements with toggles switches
Optional: with rearview camera

Further Equipment

Diesel fuel pump with auto stop
integrated tool box

Individual options

Air-cushioned comfort seat, type Grammer
Three point safety belt (suspenders)
Air-conditioning with automatic climate control
Special color
Heater with time clock

Optional Equipment

Equipment for heavy lifting
Biodegradable hydraulic oil
Road Equipment (country-specific)
Automatic central lubrication system
Safety valves on the dipper cylinder
Turning light on the roof

FOPS-roof
LED-additional light on the boom assembly
LED-lights
Xenon lights
Lightning system on the roof
Reversibal fan (reverse ventilation)
Additional external tool box

Options Hydraulic

Hydraulic preparation for winch
Circuit No. 3 for additional functions (40 l/min/10.6 US-gall. - digital - double acting)
Circuit No. 4 for hydraulic quick hitch
Powerline M5 - for maximum efficiency for accessories which demand a high oil flow
Hydraulic affluent filter
Leakage line
Electrically switchable check valves

Type specific options

M520 & M525: Hydraulic free wheels on driving wheels
M530 & M535: Mechanical or hydraulic lifting axle of small wheels
M540 & M545: Hydraulic mountain steel claws (rigid, mechanically extendable or hydraulically telescoped)

Accessories

Digging buckets 400/600/800/1000 mm
Hydraulic grading bucket1400 mm
Grading bucket, rigid 1300/1500 mm
Hydraulic quick hitch M5
Powertilt with hydraulic quick hitch
Tiltrotator with/without grapple
Oil-Quick-Coupling system
Original Menzi Universalgrab type UG12
Hydraulic Hammer / concrete crusher
Hydraulic hedge shear / Feller-Buncher
Mowers /hydr.mowing bucket
Drill rigs
Hydraulic Mowing bucket
Latticed bucket/ Skimmer bucket/ Crushing bucket
Stump cutter / Compression vibro plate
Winch
other accessories on onquiry

M5

Dimensions

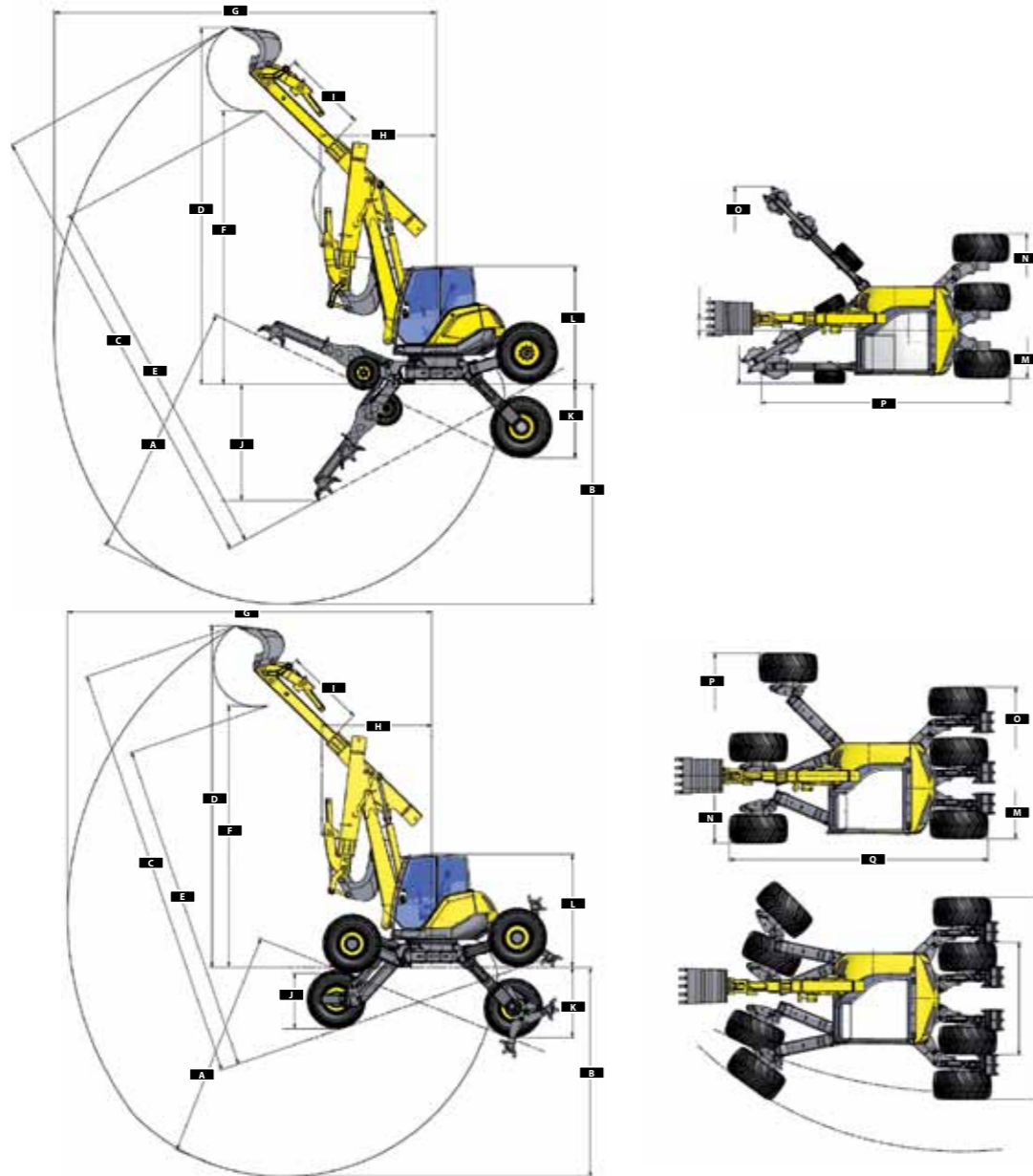

Dimensionen in mm		M520	M525	M530	M535	M540	M545
A	Max. Excavation depth with adjusted chassis	5470	16'11"	5470	16'11"	5460	17'11"
B	Max. Excavation depth chassis horizontal	4730	15'6"	4730	15'6"	4730	15'6"
C	Max. Excavation height with adjusted chassis	9870	32'4"	9910	32'4"	9870	32'4"
D	Max. Excavation height chassis horizontal	7700	25'3"	7700	25'3"	7700	25'3"
E	Max. Discharge height with adjusted chassis	7940	26'	7970	26'1"	7940	26'
F	Max. Discharge height chassis horizontal	5890	19'3"	5890	19'3"	5890	19'3"
G	Max. Jib Range	8210	26'11"	8210	26'11"	8210	26'11"
H	Min. Swivelling radius	2480	8'1"	2480	8'1"	2480	8'1"
I	Dipper length	1800	5'10"	1800	5'10"	1800	5'10"
J	Positioning range stabilizers (M340: front wheels)	2500	8'2"	2500	8'2"	2510	8'2"
K	Positioning range hub drive (M340: rear wheels)	1580	5'2"	1650	5'5"	1570	5'1"
L	Transport height	2550	8'4"	2550	8'4"	2550	8'4"
M	Minimum width hub drive, transport width	2230	7'3"	2370	7'9"	2230	7'3"
N	Max. positioning width hub drive / rear wheels	4530	14'10"	4680	15'4"	4530	14'10"
O	Max. positioning width stabilizers / front wheels	6730	22'1"	6720	22'	6730	22'1"
P	Chassis length	5830	19'1"	5960	19'6"	5040	16'6"

Masse variieren je nach Bereifung/Werkzeug · Technische Änderungen vorbehalten / 0213

Menzi Muck **M520**
 Menzi Muck **M525**
 Menzi Muck **M530**
 Menzi Muck **M535**
 Menzi Muck **M540**
 Menzi Muck **M545**

M5



The Highlights:

- Wide angle kinematics
- Force multiplier
- APM steering
- Panoramic view cab
- low fuel consumption

The models of the new M5-series

Menzi Muck M520

Hydrostatic two wheel drive
 Two removable shafts with steering wheels
 Hydraulic telescope support

Menzi Muck M525

Hydrostatic two wheel drive
 Two removable shafts with steering wheels
 Hydraulic telescope support
 Hydraulic rear steering

Menzi Muck M530

Hydrostatic all wheel drive over two big and two small tires
 Hydraulic telescope support

Menzi Muck M535

Hydrostatic all wheel drive
 Two removable shafts with steering wheels
 Hydraulic telescope support
 Hydraulic rear steering

Menzi Muck M540

Hydrostatic all wheel drive over four equal big tires
 P-Matic parallel-support

Menzi Muck M545

Hydrostatic all wheel drive over four equal big tires
 P-Matic parallel-support
 sensor steered all wheel steering