

Link-Belt®

LS-98A

Wire Rope Crawler Excavator/Crane

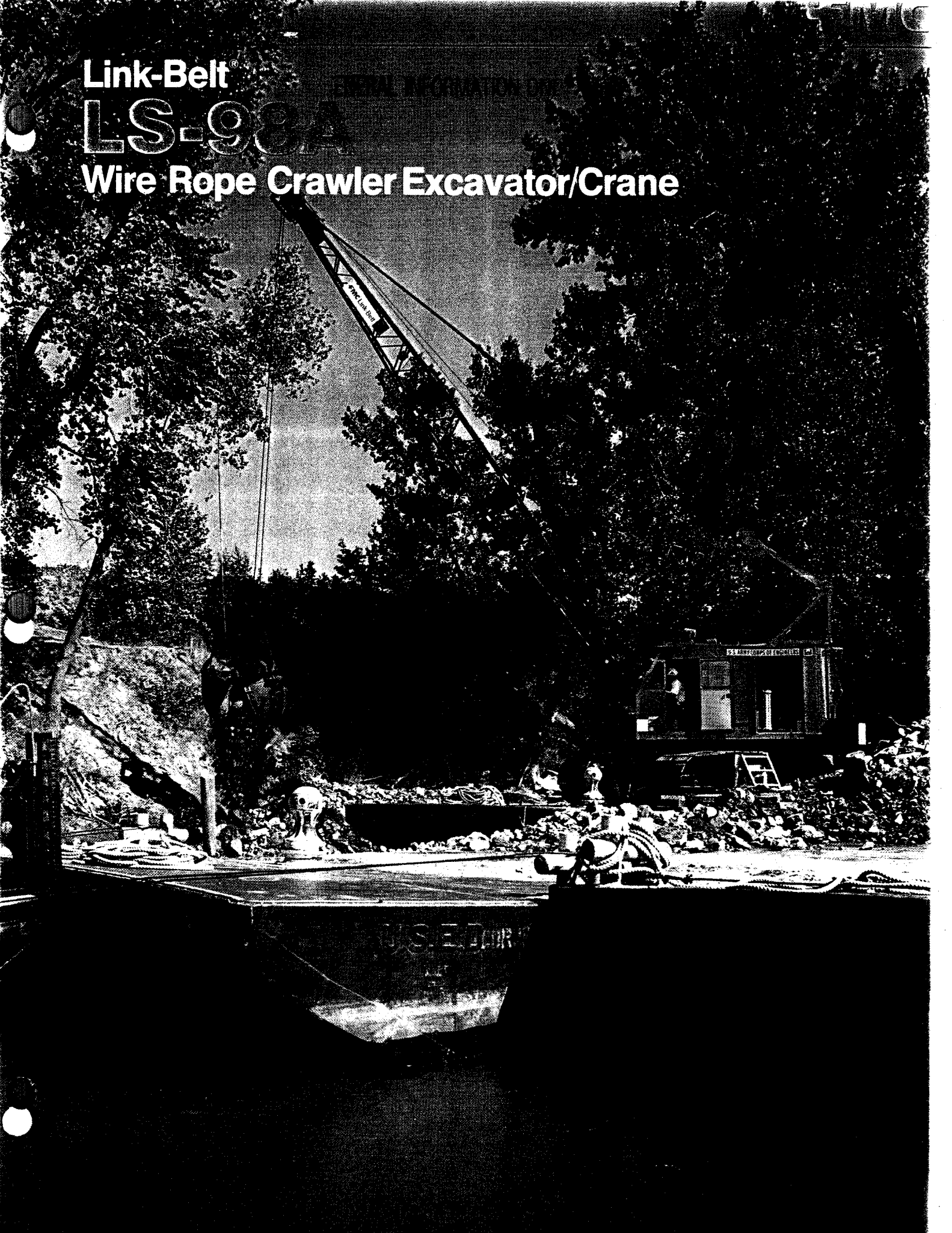

# LS-98A Serviceability

*Exclusive Full-Function design with easy-to-reach components*

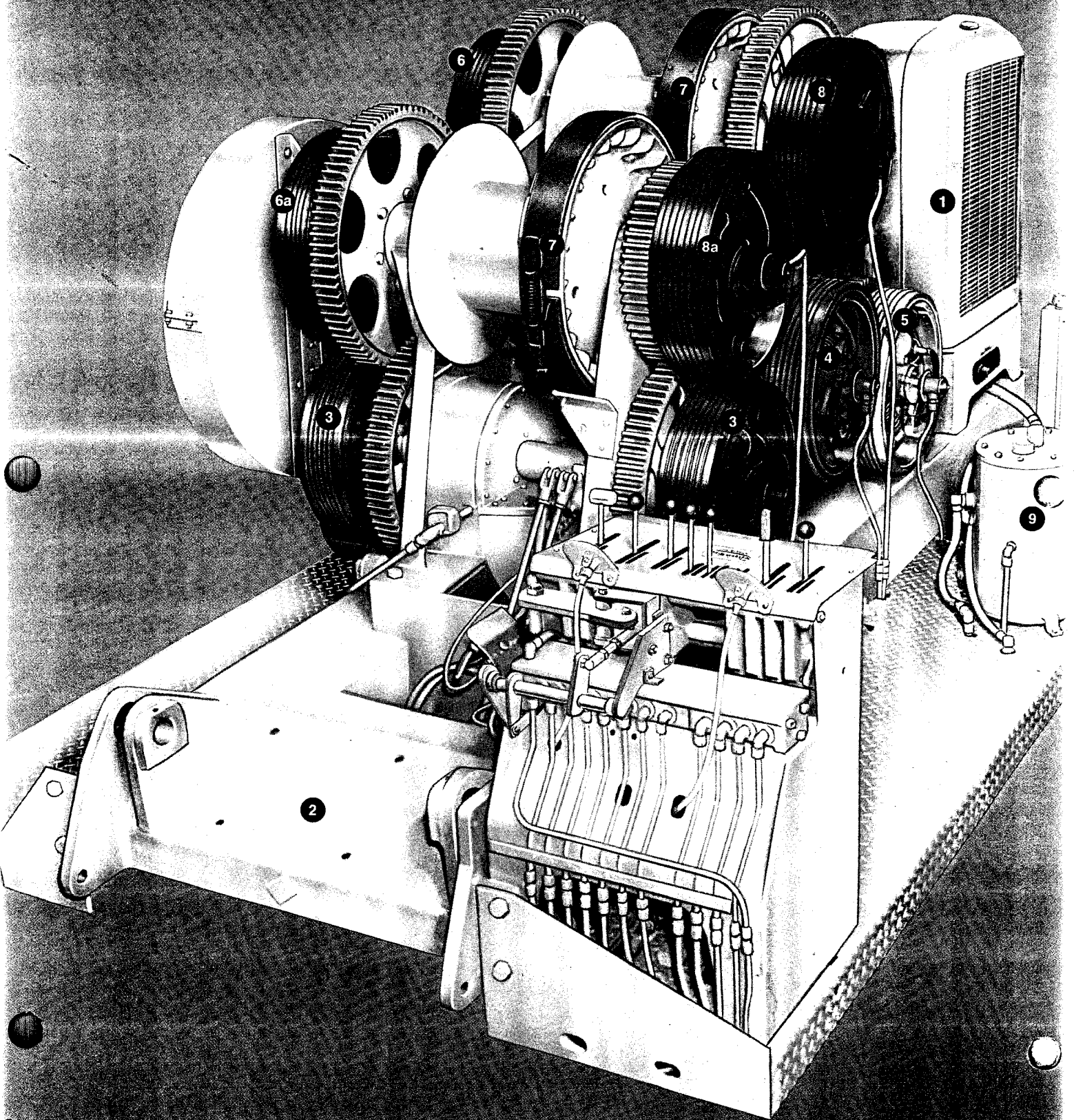



# LS-98A Controllability

Exclusive Speed-o-Matic® power hydraulic control system

## GENERAL INFORMATION ONLY

- 1 **Engine:** Diesel equipped with friction clutch, hydraulic coupling or torque converter.
- 2 **Frame:** Fixture welded, then stress relieved for strength and durability. Line bore accuracy for proper shaft and gear alignment for less component wear and lower maintenance cost.
- 3 **and 4: Travel and swing:** (Independent is optional.) Two-shoe power hydraulic controlled travel clutches (3) transmit power into the travel sprockets. Swing clutches (4) power the swing pinion. (Only left hand swing clutch is visible.)
- 5 **Boomhoist:** Independent, gear driven. Two-shoe power hydraulic controlled clutch for boom raising and lowering. (Only left hand clutch is visible.)
- 6 **6a. Hoist clutches:** Two-shoe power hydraulic controlled rear drum (6) and front drum (6a). (Only clutch drums are visible.)
- 7 **Drum brakes:** Mechanically operated by foot pedals. Separated from 2-shoe clutches to eliminate heat transfer, resulting in cooler brakes and clutches for longer component life. Brake drum is splined to the drum shaft.
- 8 **8a. Power load lowering clutches:** (Optional) independent. Two-shoe, power hydraulic controlled. Ideal for powering down light loads, and controlled lowering of heavier loads.
- 9 **Speed-o-Matic® power hydraulic control system:** Vane-type pump, belt driven from engine, piston-type accumulator, and sump tank. Normal system operating pressure is 900-1050 psi (6 206 - 7 240 kPa). Short-throw control levers actuate variable pressure valves which direct oil under variable pressure to each operating clutch.

**Full-Function design:** Offers a separate shaft, set of clutches, and gears for swing/travel, rope drums and boom hoist for increased component life. Shafts have involute splines, and mounted on anti-friction bearings — no press fits — all for easier component removal. Clutches and gears are outside the side housings for service accessibility.

### Control system

For superb control of all the machine functions, the LS-98A incorporates the exclusive Speed-o-Matic power hydraulic control system. This system is unaffected by day-to-day atmospheric variations and does not require priming or bleeding. Oil under variable pressure does the work. Operator can complete more cycles per shift.

### Interchangeable two-shoe clutches

Short throw levers in operator's control console actuate variable pressure valves from which oil under variable pressure is directed to the various hydraulic clutches for prompt, positive engagement of 2-shoe clutches or other functions. Clutches can be partially engaged for smooth acceleration and deceleration of swing, travel, inhaul, hoist and booming. The 2-shoe clutches are self-compensating over a wide range of lining wear and heat expansion, requiring less operator attention. The control system is time tested and proven throughout the world.

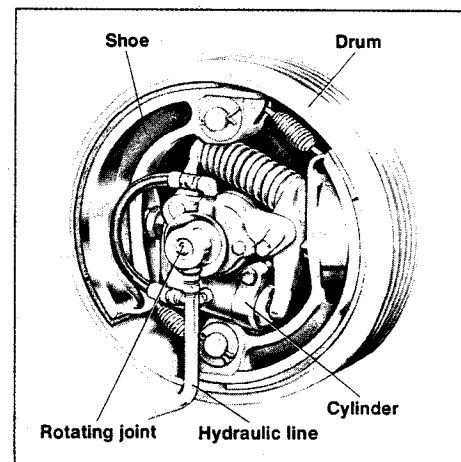

Two-shoe clutches

### Swing brake

Spring applied or power hydraulically released under control of the operator. Acts to hold upper and boom at any swing position, or can be partially engaged for a slight drag to control side drift. The brake is controlled from the operator's position

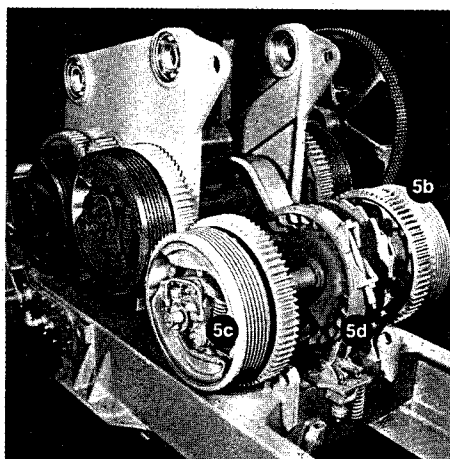

Independent boomhoist

### Independent boomhoist

Gear driven with power hydraulic clutch control for boom raising (5b, clutch drum only visible) and boom lowering (5c). An automatic, spring applied rope drum brake (5d) is power hydraulically released. A manually controlled rope drum locking pawl is standard.

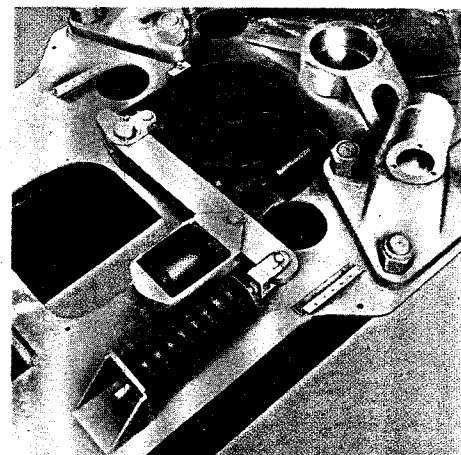

Swing brake

through a variable pressure control valve. A mechanical swing lock is also standard equipment.

# LS-98A Maneuverability

Power hydraulic steering-travel

GENERAL INFORMATION ONLY

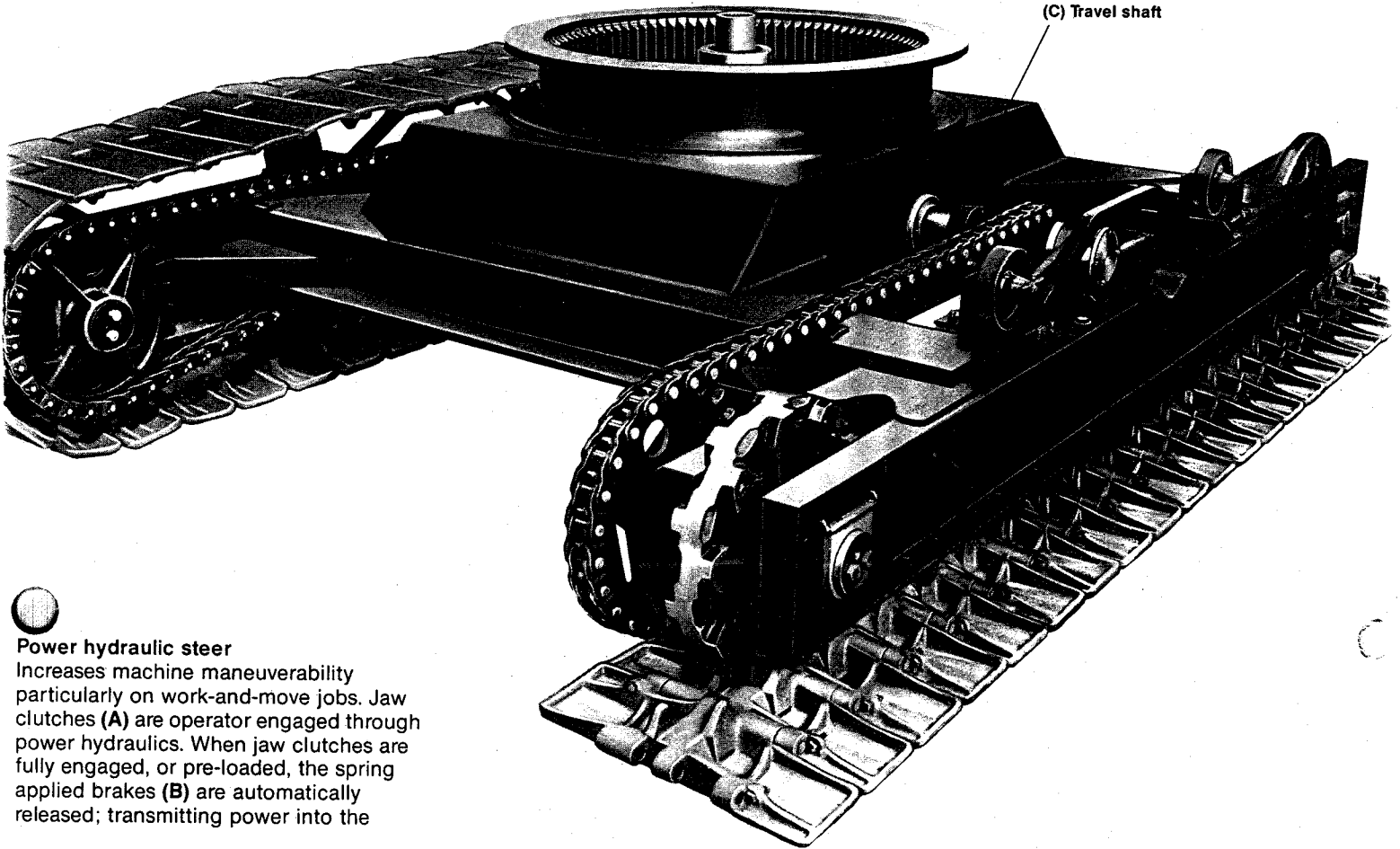

(C) Travel shaft

## Power hydraulic steer

Increases machine maneuverability particularly on work-and-move jobs. Jaw clutches (A) are operator engaged through power hydraulics. When jaw clutches are fully engaged, or pre-loaded, the spring applied brakes (B) are automatically released; transmitting power into the

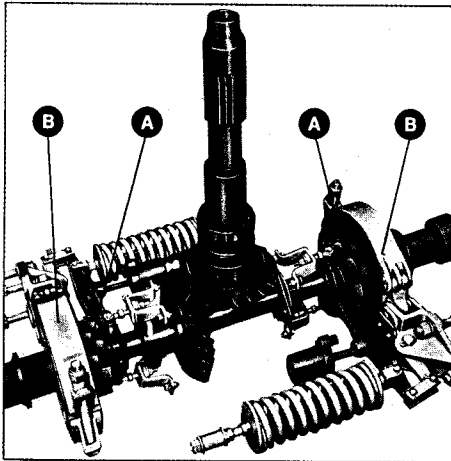

Power hydraulic steer

travel shaft, and chain drive mechanism. Jaw clutches (A) are engaged independently for steer by either of two operator steer control levers. They are simultaneously engaged for straightline travel by the two steer control levers. Brakes (B) also serve as digging brakes while working. The steer/travel mechanism is completely enclosed within the lower frame . . . no components protrude below the underside of the carbody to be subject to damage when working or being transported.

## Rugged lower

All-welded, stress relieved and then line bored for mounting of the travel shaft (C). The overall crawler length 15'1" (4.60 m) provides mobility plus over-the-end stability for dragline, clamshell, wrecking ball, magnet or lifting crane applications.

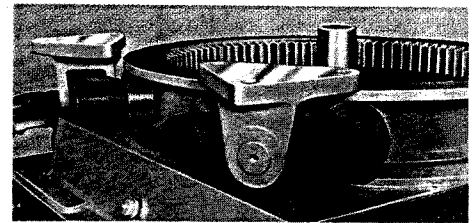

Conical hook rollers

## Eight hardened, conical hook rollers

Rollers are mounted on anti-friction bearings and join the upperstructure to the crawler mounting. Rollers, mounting brackets and roller path are all heat treated for long, trouble-free service. Rollers are shim-adjusted for wear.

# LS-98A Dragline production capability

*More engine horsepower to the rope drums*

GENERAL INFORMATION ONLY

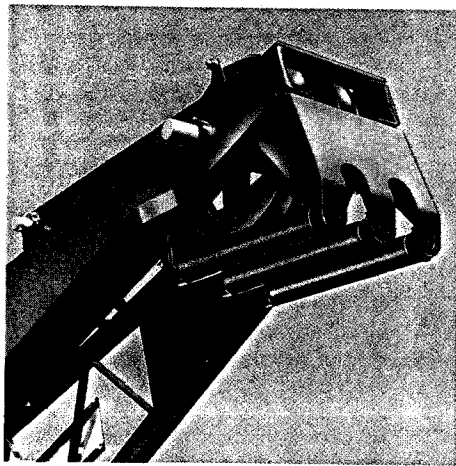

Angle boompoint

**Angle boompoint**  
Sheaves and roller-type hoist rope guards are mounted on anti-friction bearings for increased rope and sheave life.

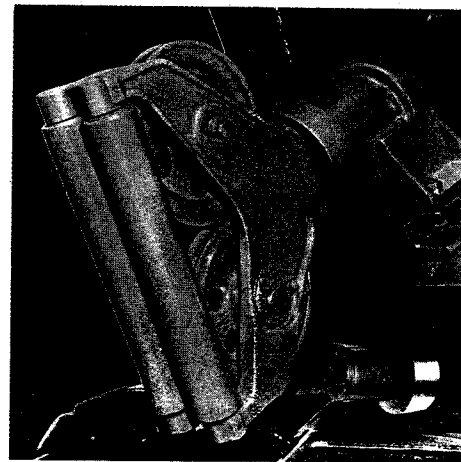

Full-revolving fairlead

### Rope drum horsepower

The usable rope drum horsepower is the net engine horsepower **less** frictional losses of the power train. The Link-Belt® LS-98A excavator/crane power train, with its machine cut gears, anti-friction bearings and in-line shaft mountings reduce frictional losses. Thus, more usable engine horsepower is available at the rope drums, maintaining high production standards.

### Full-revolving fairlead

Rotates to insure full inhaul rope support in all positions. All moving parts are mounted on anti-friction bearings. Saves inhaul rope and permits greater economy.

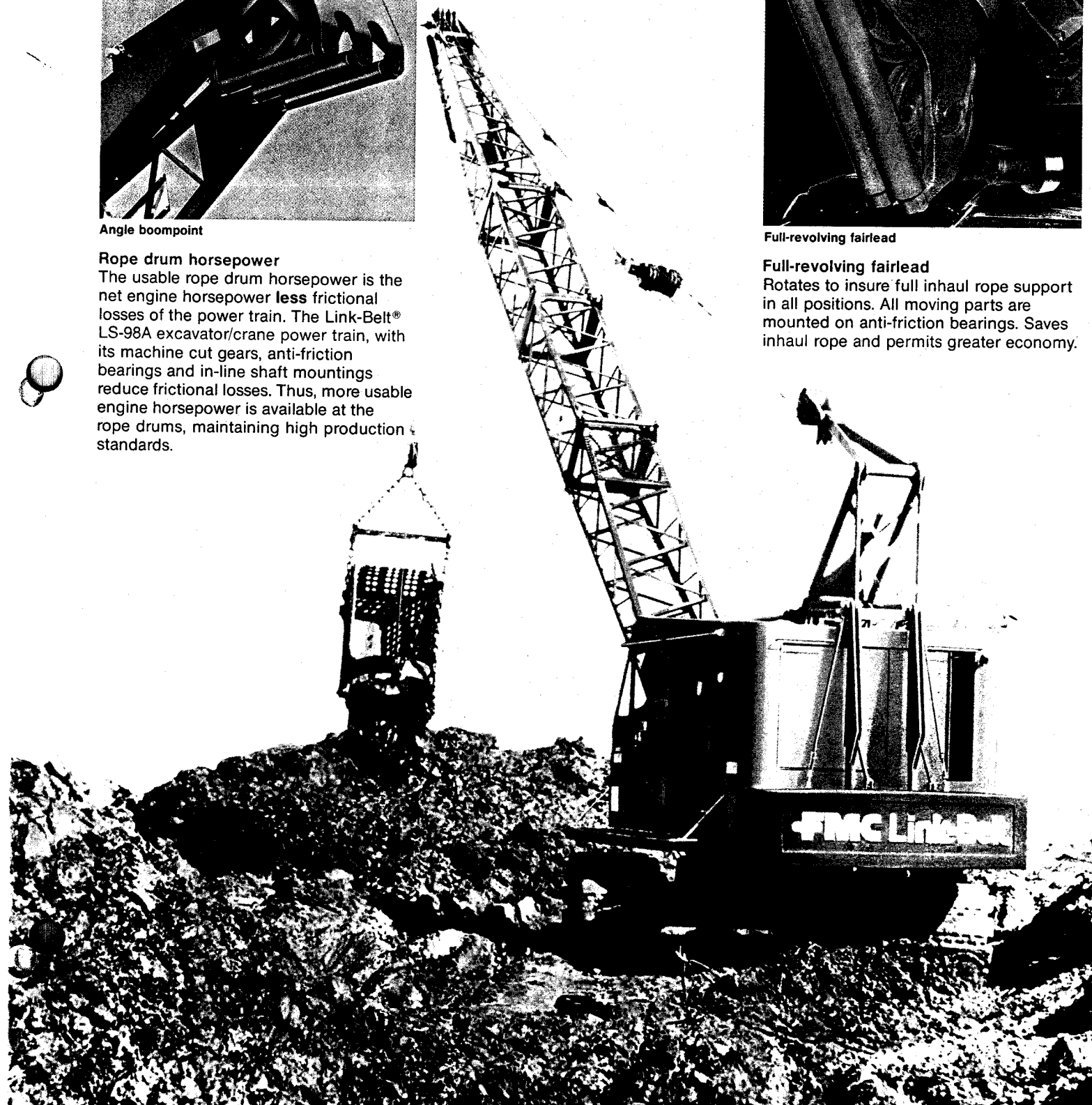

# LS-98A Flexibility

Options to tailor the machine to the job

## Wide choice of options

The flexibility of the Link-Belt® excavator/crane Full-Function design results in the availability of options, all designed to maximize the usefulness and productivity of the LS-98A, unmatched by other cranes.

With the optional independent swing and travel, the LS-98A is able to swing while traveling, or travel while swinging for greater on-the-job maneuverability.

Tailor the LS-98A to the job from a wide choice of options to meet varied job application requirements. The result is increased on-the-job machine and load handling capability for increased profits.

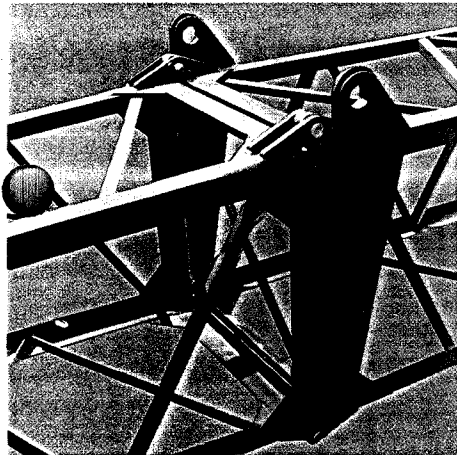

Pin-connected angle boom

## Boom attachment

The Link-Belt 40-ton (36.28 metric ton) LS-98A lift crane is available with a **pin-connected angle boom**. Basic boom is 40' (12.19 m) in length, with extensions available up to a maximum boom length of 100' (30.48 m). A 20' (6.10 m). Bolt-connected angle jib is available, with 10' (3.05 m) extensions up to maximum jib

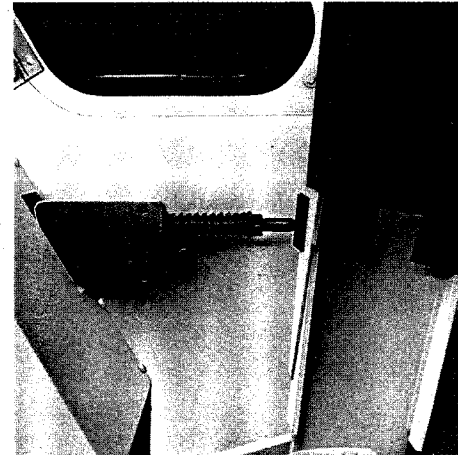

Boomhoist limiting device

## Boomhoist limiting device

This device is for added safety in close-radius booming. When the boom approaches minimum radius this mechanism acts to disengage the boom raising clutch with simultaneous engagement of the boomhoist brake.

GENERAL INFORMATION ONLY

Jib mast

length of 40' (12.19 m). Jib mast is equipped with equalizer sheaves for frontstay and backstay lines, and a deflector sheave, mounted on anti-friction bearings for the jib hoist line.

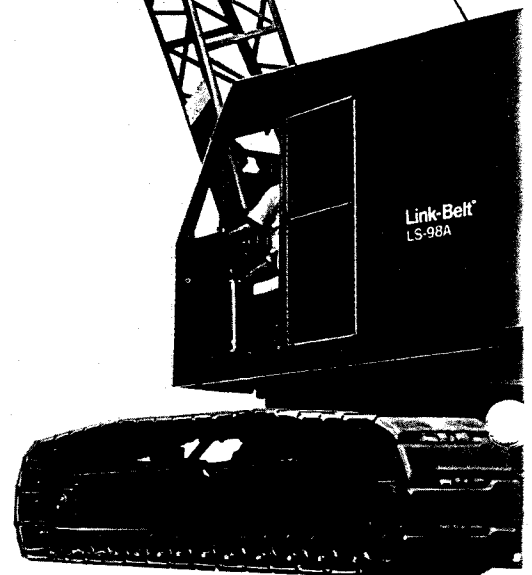

## GENERAL INFORMATION ON

### Two-speed rope drums (optional)

For specialized applications, 2-speed gear driven rope drums are available. Clutches (A) operate at standard hoist line speed. Clutches (B) operate at 90% higher than standard speed. However, with this arrangement, clutch-controlled power load lowering is not available. Loads must be lowered on the drum brake(s).

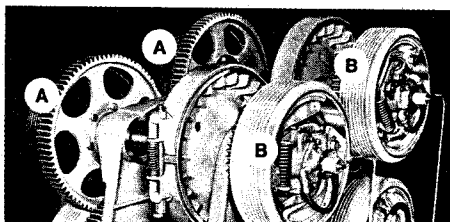

Two-speed rope drums

40% decreased speed for either hoisting or lowering. Standard speed is retained for swing, travel, boomhoist and third drum. Engaging the 2-shoe clutch provides standard rope drum speed. This option will greatly increase machine production.

### Third rope drum (optional)

A gear-driven third drum is available. Particularly valuable for "snaking in" a load, the third drum is high in line speed and rope capacity and is completely independent of all other machine functions.

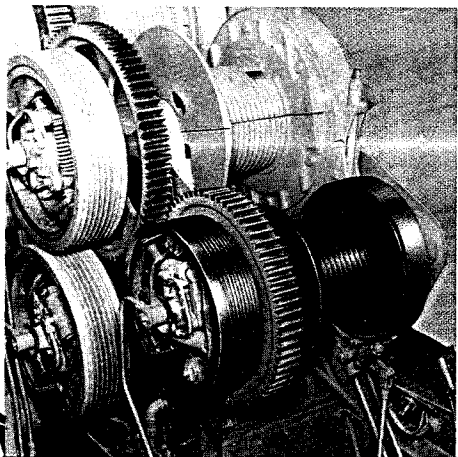

Third rope drum

### Two-speed, planetary driven hoist/lowering rope drum (optional)

An exclusive, independent planetary arrangement can be mounted at either or both hoist and lowering ends of extended drum shafts. The planetary arrangement can provide up to 70% increased speed or

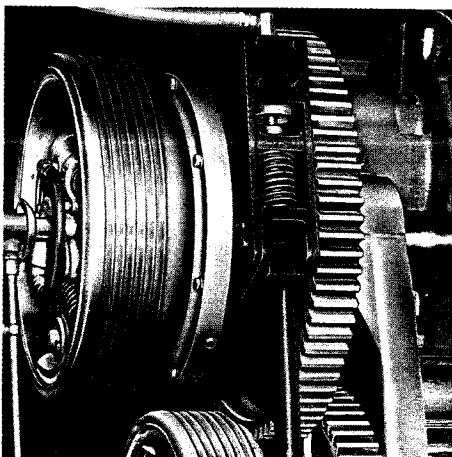

Two-speed, planetary driven hoist/lowering rope drum

### Auxiliary two-shoe rear drum brake (optional)

The addition of the auxiliary 2-shoe rear drum brake nearly doubles the rear drum total effective braking area. The brake is power hydraulically applied with a variable pressure control valve interconnected with the standard drum brake linkage for simultaneous engagement of both drum brake band and shoes. When the rear

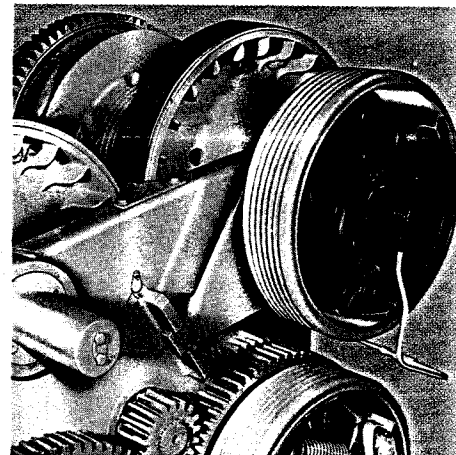

Auxiliary two-shoe rear drum brake

drum auxiliary brake is installed, power load lowering, planetary lowering or 2-speed gear-driven hoist are not available.

### Elevated operator's cab (optional)

2' (0.61 m), 4' (1.22 m), or 7' (2.13 m) above the standard position are available. This option puts the operator up where he can see his work on specialized loading jobs. The result is greater speed of operation.

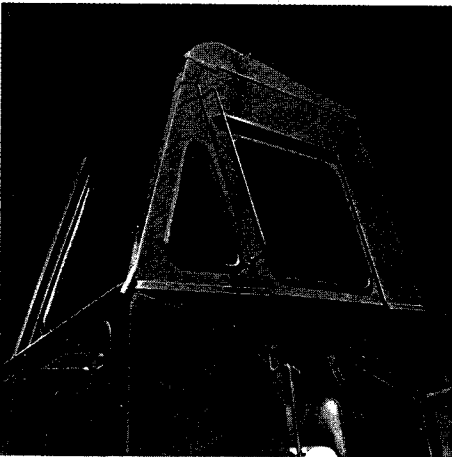

Elevated operator's cab

Retractable gantry

FMC Link-Belt



# LS-98A Dependability

*In dragline - clamshell - magnet - lifting crane*

## GENERAL INFORMATION ONLY

Through the years, the LS-98A has developed a reputation for dependability not only in day-to-day cycle work with magnet, clamshell or dragline bucket, but also as a lifting crane.

Stress relieved frames followed by in-line bores means longer gear and shaft life.

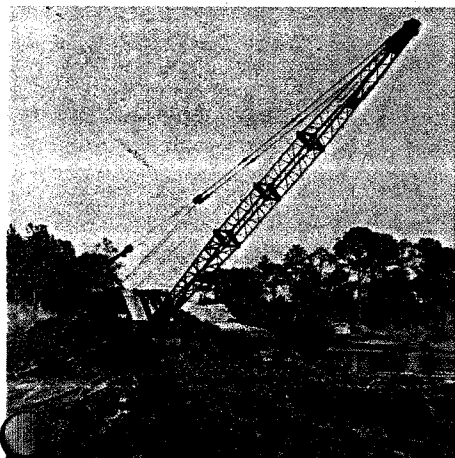

Speed-o-Matic® power hydraulic controls and interchangeable 2-shoe clutches decrease cycle time plus reduce maintenance cost. And, resale value of the quality-designed LS-98A is amazingly high compared to competitive size machines.

The LS-98A design benefits:

- **Serviceability** (page 2)  
*FMC exclusive Full-Function gear train design with easy-to-reach components.*
- **Maneuverability** (page 4)  
*Power hydraulic controlled swing and travel; 15' 1" (4.60 m) crawler length and conical hook rollers on anti-friction bearings.*
- **Flexibility** (page 6-7)  
*Wide choice of options to tailor the LS-98A to the job.*
- **Controllability** (page 3)  
*FMC exclusive Speed-o-Matic® power hydraulic control system, plus 2-shoe clutches, independent boomhoist and swing brake.*
- **Dragline production capability** (page 5)  
*High usable rope drum horsepower. Boompoint sheaves, rope guard rollers and fairlead components mounted on anti-friction bearings.*
- **Dependability** (page 8)  
*Stress relieved frames. Shafts mounted in in-line bores. Speed-o-Matic power hydraulic control system and interchangeable 2-shoe clutches.*

We are constantly improving our products and therefore reserve the right to change designs and specifications.

**FMC Corporation Cable Crane & Excavator Division Cedar Rapids Iowa 52406**

Link-Belt® cranes/excavators manufactured in: Cedar Rapids Iowa • Lexington & Bowling Green Kentucky • Ontario Canada • Milan Italy • Queretaro Mexico & Nagoya Japan (under license)



# General Specifications

Link-Belt® 40-ton (18.14 metric ton)

Wire rope crawler crane/excavator

## LS-98A

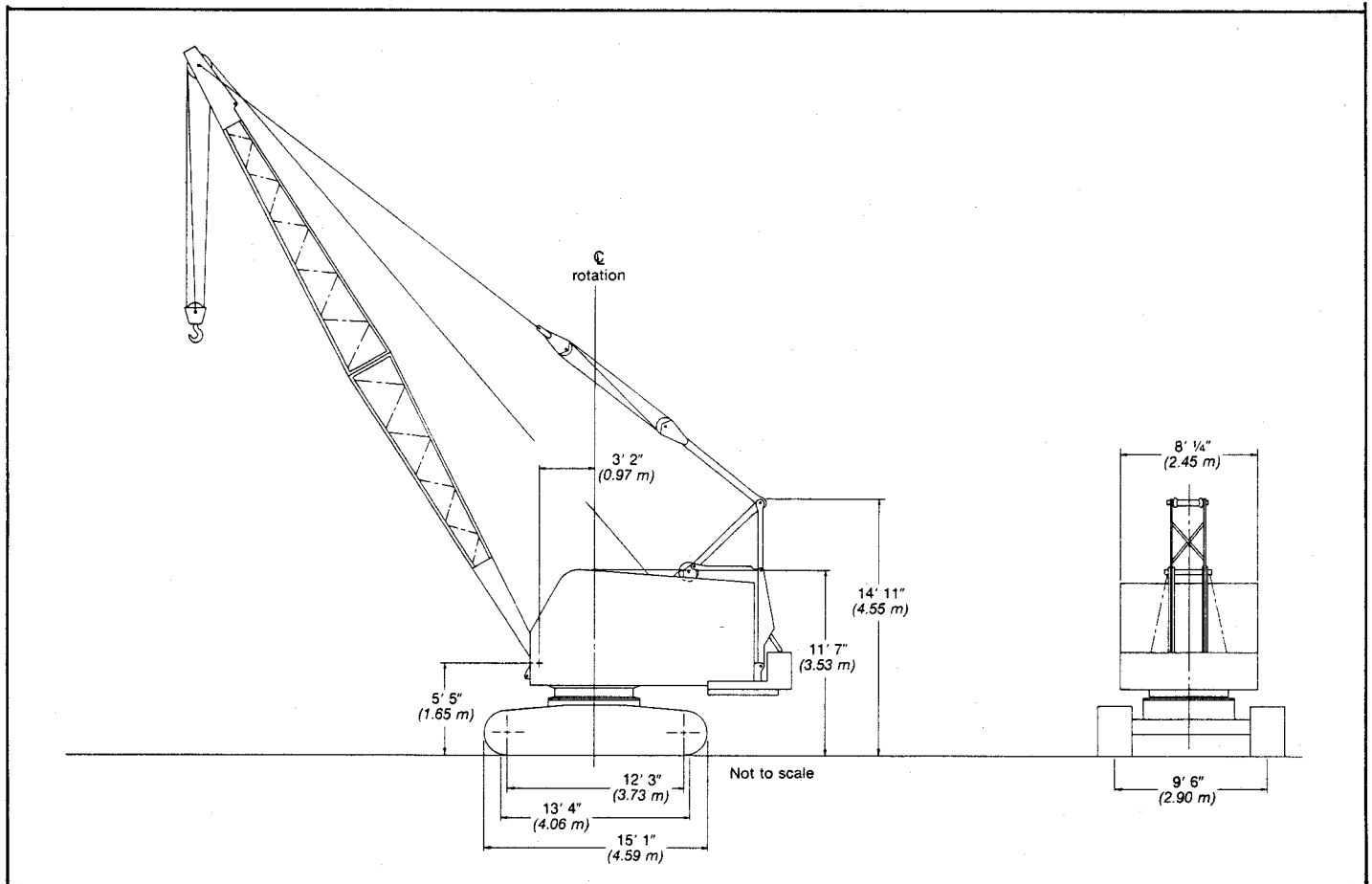

General dimensions	Feet	meters
Basic angle boom length	40' 0"	12.19
Overall height:	—	—
— Retractable high gantry raised	14' 11"	4.55
— Retractable high gantry lowered	11' 7"	3.53
— Standard low gantry	11' 1"	3.38
Overall width of cab less catwalks	8' ¼"	2.45
Overall width of cab with catwalks both sides	11' ¼"	3.36
Clearance under counterweight "A"	3' 9"	1.14
Clearance under counterweight "AB"	3' 5"	1.04
Tailswing of counterweight "A"	11' 5"	3.48
Tailswing of counterweight "AB"	11' 5"	3.48

General dimensions	Feet	meters
Overall width of counterweight	8' ¼"	2.45
Overall width of machine:	—	—
— 24" (0.61 m) wide track shoes	11' 6"	3.51
— 30" (0.76 m) wide track shoes	12' 0"	3.66
— 36" (0.91 m) wide track shoes	12' 6"	3.81
— 42" (1.07 m) wide track shoes	13' 0"	3.96
Minimum ground clearance:	—	—
— 24" (0.61 m) wide track shoes	12½"	0.32
— 30" (0.76 m) wide track shoes	13"	0.33
— 36" (0.91 m) wide track shoes	13½"	0.34
— 42" (1.07 m) wide track shoes	13½"	0.34

**GENERAL INFORMATION ONLY**

## Machine working weights — approximate

Based on standard machine including GM4-71N diesel engine and friction clutch, six conical hook rollers, independent boom hoist with lowering clutch, boomhoist limiting device, non-independent swing and travel, swing brake, low gantry, drum rotation indicators, and 9' 6" (2.90 m) gauge by 15' 1" (4.60 m) long crawler lower with 24" (0.61 m) wide track shoes and track rollers with dirt seals, plus the following:	Crawler mounting 15' 1" (4.60 m) overall length			
	Counterweight "A"		Counterweight "AB"	
	Pounds	kilograms	Pounds	kilograms
Lifting crane — includes necessary drum laggings, main load hoist wire rope, boom angle indicator, three head sheaves, boom backstops, hoist line deflector roller, eight-part boom hoist and pendants, counterweight "B" and basic 40' (12.19 m) angle boom.	—	—	70,660	32 051
Dragline — includes necessary drum laggings, hoist and inhaul lines, fairlead with adapter base, boom angle indicator, one head sheave, boom backstops, hoist line deflector roller, eight-part boom hoist and pendants, and maximum 60' (18.29 m) angle boom.	66,285	30 067	—	—
Clamshell or magnet — includes necessary drum laggings, holding and closing lines, boom angle indicator, three head sheaves, boom backstops, hoist line deflector roller, eight-part boom hoist and pendants, and maximum 60' (18.29 m) angle boom.	65,550	29 733	—	—
Hoe — includes necessary drum laggings, mast backstops, one cubic yard (0.76 m <sup>3</sup> ) 39" (0.99 m) outside lip width Esco bucket with side cutters for 43" (1.09 m) cutting width and 20' (6.10 m) boom.	71,710	32 528	—	—
Hoe — includes necessary drum laggings, mast backstops, auxiliary rear drum brake, one cubic yard (0.76 m <sup>3</sup> ) 39" (0.99 m) outside lip width Esco bucket with side cutters for 43" (1.09 m) cutting width, and 23' (7.01 m) boom.	73,545	33 360	—	—
Hoe with hydraulic digging bucket — includes necessary drum laggings, mast backstops, complete hydraulic system and cylinder, auxiliary rear drum brake, 1¼ cubic yard (0.96 m <sup>3</sup> ) 39" (0.99 m) outside lip width Esco bucket with side cutters for 43" (1.09 m) cutting width, and 20' (6.10 m) boom (available only on machines equipped with either GM 6-71N or Caterpillar 3306T diesel engines with friction clutch).	74,300	33 702	—	—

## Weight deductions for transporting — approximate

Deduct for removal of the following components:	Crawler mounting 15' 1" (4.60 m) overall length	
	Pounds	kilograms
Counterweight "A" ①	14,800	6 713
Counterweight "B" ①	5,200	2 359
Basic 40' (12.19 m) angle boom including head machinery and pendants	3,320	1 506

① Based on machine equipped with GM engines. For machines equipped with Caterpillar engine, subtract 900 lbs. (408 kg) from these weights.

## General specifications

### Crawler mounting



Lower frame

All-welded, stress relieved, precision machined; line bored for horizontal travel shaft.

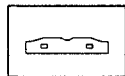

Crawler side frames

All-welded, stress relieved, precision machined; welded integral with lower frame cross axles.

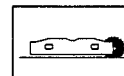

Track drive sprockets

Cast steel, heated treated, involute splined to shafts which are mounted on bronze bushings. Track/chain drive sprockets splined on single shaft which is mounted on bronze bushings in crawler side frames; one assembly per side frame.

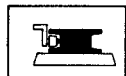

Hook roller path

Double flanged, machined roller path; swing pinion meshes with internal swing (ring) gear which is integral with roller path.

GENERAL INFORMATION ONLY

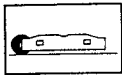

**Track idler wheels**

Cast steel, heat treated, mounted on bronze bushings; one track idler wheel per side frame. Axle adjusted for track take up. Optional heavy duty track shoes require a heavy duty track chain drive sprocket and idler wheel; idler wheel mounted on anti-friction bearings.

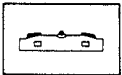

**Track carrier rollers**

Two cast iron rollers and one slide rail on top of each side frame.



**Track rollers**

Heat treated, mounted on sintered iron bushings and equipped with dirt seals; nine per crawler side frame.

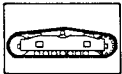

**Tracks**

Heat treated, self-cleaning, multiple hinged track shoes joined by one-piece full floating pins; 43 shoes per side frame. Standard shoes: 24" (0.61 m) wide; optional: 30", 36", or 42" (0.76 m, 0.91 or 1.07 m) wide. Optional heavy duty shoes: 30" or 36" (0.76 m or 0.91 m) wide, joined by two-piece pins; require heavy duty sprocket and idler.

**Track/chain adjustment** — Track drive chains adjusted by shimming axles of track/chain drive sprockets. Track adjusted with threaded adjusting bolts attached to track idler (wheel) axles.



**Travel**

Includes two-speed travel. Standard: travel non-independent of swing; operator must manually shift gears from swing to travel prior to actuating two-shoe Speed-o-Matic® power hydraulic swing/travel clutches. *Optional:* travel independent of swing; permits simultaneous swing and travel with separate set of shafts and clutches. Four-piece traction shaft joined with involute splined couplings; inner traction shaft mounted on bronze bushings in precision bored lower frame. Outer traction shaft engages splines in chain drive sprockets which are mounted on bronze bushings in side frames. Powered by bevel gear drive enclosed in oil within lower frame. *Optional:* Instant travel for forward and reverse.

**Steering** — Power hydraulic. Travel/steer jaw clutches hydraulically engaged, spring released. External contracting band brakes, spring applied, hydraulically released for travel/steer/digging/parking. Brakes simultaneously released by interconnecting mechanical linkage as jaw clutches are pre-loaded or fully engaged; brakes are automatically set when travel/steer levers are in neutral. Two 18" (0.46 m) diameter by 4" (0.10 m) wide brake bands; effective lining area 164 square inches (1 058 cm<sup>2</sup>) per brake.

**Travel speeds** — Low: 0.79 mph (1.27 km/h); high: 1.78 mph (2.86 km/h).

**Gradeability** — 30%.

Ground contact area and ground bearing pressure (based on standard machine equipped with "AB" counterweight, 40' (12.19 m) angle boom and standard track shoes, sprocket and idler).

Track shoes		Ground contact area		Ground bearing pressure	
Inches	meters	Square inches	cm <sup>2</sup>	P.s.i.	kPa
24	0.61	7,600	49 035	9.30	64.12
30	0.76	9,500	61 294	7.44	51.30
36	0.91	11,500	74 198	6.14	42.34
42	1.07	13,300	85 812	5.31	36.61

## Revolving upperstructure



**Frame**

All-welded, stress relieved, precision machined; machinery side housings bolted to upper frame.

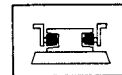

**Hook rollers**

*Standard:* six adjustable, heat-treated, conical hook-type rollers mounted on tapered roller bearings; two equalized pairs in front and two in rear. *Optional:* eight adjustable, heat-treated, conical hook-type rollers mounted on tapered roller bearings; two equalized pairs mounted both front and rear.

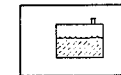

**Fuel tank**

58 gallon (220 L) capacity; equipped with fuel sight level gauge, flame arrester, and self-closing cap with locking eye for padlock.

**GENERAL INFORMATION ONLY**

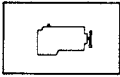

## Engines

Full pressure lubrication, oil filter, air cleaner, hour meter and hand throttle. Optional hand throttle (lever type on swing control lever) and foot throttle available. Manual control shutdown.

Engine specifications	GM 4-71N with friction clutch	GM 4-71N with hydraulic coupling	GM 4-71N with torque converter	GM 6-71N with friction clutch	Caterpillar 3306T with friction clutch
Number of cylinders	4	4	4	6	6
Bore and strokes — inches — (mm)	4¼ x 5 108 x 127	4¼ x 5 108 x 127	4¼ x 5 108 x 127	4¼ x 5 108 x 127	4¾ x 6 121 x 152
Piston displacement — cu. in. — (cm <sup>3</sup> )	284 4 650	284 4 650	284 4 650	426 6 982	638 10 457
High idle speed — r.p.m.	1,990	1,990	2,150	1,990	1,990
Engine r.p.m. at full load speed	1,850	1,850	2,000	1,840	1,825
Net engine h.p. at full load speed	110 (82 027 W)	110 (82 027 W)	125 (93 213 W)	125 (93 213 W)	110 (82 027 W)
Peak torque — ft. lbs. — joules	351 476	351 476	372 504	410 556	356 483
Peak torque — r.p.m.	1,200	1,200	1,200	1,000	1,300
Electrical system	12-volt	12-volt	12-volt	12-volt	12-volt
Batteries	Two 6-volt	Two 6-volt	One 12-volt	One 12-volt	Two 12-volt
Clutch or power take-off	Friction clutch	Hydraulic coupling Twin Disc #SP111-HP-1	Disconnect between engine and converter	Friction clutch	Friction clutch
Transmission:					
— Number chain wheel teeth	161	161	161	161	161
— Number engine pinion teeth	17	17	28	17	17

Ⓞ Allison TCDOA 435 single stage torque converter

## Power train

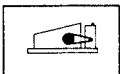

### Transmission

FMC quadruple roller chain enclosed in oil tight chain case with integral chain lubrication pump for oil stream lubrication; oil flow indicator switch.

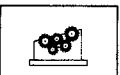

### Machinery gear train

"Full Function" design, two-directional power available for all operating shafts; shafts mounted on anti-friction bearings in precision bored machinery side housings. All load hoisting/lowering, swing and boom hoist functions completely independent of one another. Standard travel is non-independent of swing; travel independent of swing is optional and allows all functions to be completely independent of each other. Components such as gears, pinions, chain wheels, brake drums and clutch spiders are involute splined to shafts. Drum gear/clutch drum assemblies are bolted together and mounted on shafts on anti-friction bearings. Machine-cut teeth on drum gears, pinions, spur gears and chain wheel.

## Principal operating functions

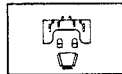

### Control system

Speed-o-Matic power hydraulic control system requiring no bleeding. Variable operating pressure transmitted to all two-shoe clutch cylinders as required. System includes constant displacement, engine-driven, vane type hydraulic pump to provide flow of oil; accumulator to maintain system operating pressure, unloader valve to control pressure in accumulator, relief valve to limit maximum pressure buildup in system, full-flow filter with 40 micron disposable filter element, and variable pressure control valves to control clutches and other operating cylinders.

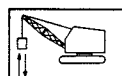

### Load hoisting and lowering

Wire rope drum gear train (front and rear main, and optional third, operating drums) powered by chain transmission from engine.

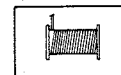

### Front and rear main operating drums

Two-piece, removable, smooth or grooved laggings bolted to brake drums which are splined to shafts. Extended length shafts permit installation of optional power load lowering clutches.

— Lifting crane operation: 13¼" (0.34 m) front and rear smooth drum laggings.

— Clamshell, magnet or dragline operation: 15¼" (0.39 m) front and rear grooved drum laggings.

*Third operating drum — Optional; mounts forward of front main operating drum. Two-piece 9" (0.23 m) or 11" (0.28 m) root diameter grooved lagging bolted to brake drum which is splined to shaft.*



**Note:** Third drum limitations:

— Dragline application: Lagging must be removed from third drum. To prevent interference of inhaul rope with third drum brake enclosure it is necessary to use ten feet longer inhaul rope than normal to leave minimum of four wraps of rope at anchor end of drum.

— Lifting crane application: To prevent interference of hoist line with third drum brake enclosure, quantity of line on front drum must be limited in certain cases. Four parts of  $\frac{5}{8}$ " (16 mm) hoist line on  $1\frac{3}{4}$ " (0.34 m) lagging may be used with booms up to 55' (16.76 m) in length at all radii. For longer boom lengths, operation is limited to certain radii and requires special investigation.

— Hoe applications: Third drum unit must be removed.



Drum clutches

Speed-o-Matic power hydraulic two-shoe clutches; internal expanding, lined shoes. Clutch spiders splined to shafts; clutch drums bolted to drum spur gears and mounted on shafts on anti-friction bearings.

**Load hoist clutches** — Speed-o-Matic power hydraulic two-shoe clutches. Front and rear main operating drums 20" (0.51 m) diameter, 5" (0.13 m) face width; effective lining area 212 square inches (1 368 cm<sup>2</sup>). Optional 20" (0.51 m) diameter, 6 $\frac{1}{2}$ " (0.16 m) face width front drum hoist/inhaul clutch; effective lining area 260 square inches (1 678 cm<sup>2</sup>). Optional third drum 17 $\frac{1}{4}$ " (0.44 m) diameter, 4" (101.60 mm) face width; effective lining area 118 square inches (761 cm<sup>2</sup>).

**Load lowering clutches** — Optional; Speed-o-Matic power hydraulic two-shoe clutches. Front and/or rear main operating drums 20" (0.51 m) diameter, 5" (0.13 m) face width; effective lining area 212 square inches (1 368 cm<sup>2</sup>). **Note:** Optional load lowering clutch on rear drum not available on machine equipped with optional auxiliary rear drum brake.

**Optional two-speed gear driven drums** — For front and/or rear hoist drums only. Intermediate gears installed in side housings between reduction shaft pinion and drum spur gears convert two-shoe Speed-o-Matic power hydraulic load lowering clutches to high-speed hoist clutches; load hoist wire rope speeds increased 90% over standard rope speeds. **Note:** Not available on drums equipped with

optional power load lowering clutch, planetary drive unit, or rear drum with auxiliary rear drum brake.

**Optional planetary drive units** — For front and/or rear drums. Planetary drive units available for up to 70% increase or 40% decrease in load hoisting on either or both drums, or load lowering on rear drum (predetermined by customer); includes special extended drum shafts. Planetary drive units mount between drum spur gears and Speed-o-Matic power hydraulic two-shoe clutch drums. Standard hoist and power load lowering clutches provide standard rope speeds. Planetaries controlled by external contracting band brakes through push buttons mounted on clutch control levers. **Note:** Not available on drums equipped with optional two-speed gear driven drum or auxiliary rear drum brake.



Drum brakes

External contracting band; brake drum involute splined to shaft. Mechanically foot pedal operated; foot pedal equipped with latch to permit locking brake in applied position.

**Front and rear main drums** — Brakes 27" (0.69 m) diameter, 4 $\frac{1}{2}$ " (0.11 m) face width; effective lining area 301 square inches (1 942 cm<sup>2</sup>).

**Optional third drum** — Brake 18" (0.46 m) diameter, 3 $\frac{1}{2}$ " (88.90 mm) face width; effective lining area 136 square inches (877 cm<sup>2</sup>).

**Auxiliary rear drum brake** — Optional with other attachments. Internal expanding Speed-o-Matic power hydraulic two-shoe type; brake drum 23" (0.58 m) diameter, 6" (0.15 m) face width. Increases brake lining contact area by 287 square inches (1 852 cm<sup>2</sup>). Pressure on mechanical brake pedal applies standard rear drum brake band and the auxiliary two-shoe brake simultaneously. Mechanical linkage actuates control mechanism of a variable pressure valve to direct hydraulic pressure to the auxiliary brake cylinder. Brake shoe spider splined to shaft; brake drum bolted to anchor plate attached to machinery side housing. **Note:** Auxiliary rear drum brake not available on rear drum equipped with optional power load lowering clutch, two-speed gear driven drum, or planetary drive unit for power lowering.

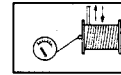

Drum rotation indicators

Standard for front and rear main operating drums. Two rotating dials mounted on control stand; dials actuated by flexible shaft drive from front or rear main operating drum.

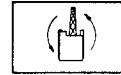

Swing system

**Standard:** swing non-independent of travel; operator must manually shift gears from travel to swing prior to actuating two-shoe Speed-o-Matic power hydraulic swing/travel clutches. **Optional:** swing independent of travel; permits simultaneous swing and travel with separate set of shafts and clutches. Spur gear driven; single bevel gears (enclosed and running in oil) on horizontal swing shaft and vertical swing drive shaft. Swing pinion involute splined to vertical swing shaft, meshes with internal teeth of swing (ring) gear.



Swing clutches

Speed-o-Matic power hydraulic two-shoe clutches. **Standard:** 20" (0.51 m) diameter, 6 $\frac{1}{2}$ " (0.16 m) face width, lined shoes; effective lining area 260 square inches (1 678 cm<sup>2</sup>). **Optional for lifting crane only:** clutch drums 20" (0.51 m) diameter, 5" (0.13 m) face width, lined shoes; effective lining area 212 square inches (1 368 cm<sup>2</sup>).

**Swing brake** — External contracting band; spring applied, power hydraulically released by operator controlled lever. Swing non-independent of travel: brake drum involute splined to swing brake shaft. Swing independent of travel: brake drum involute splined to vertical swing drive shaft. Brake 14" (0.36 m) diameter, 2 $\frac{1}{4}$ " (57.15 mm) face width; effective lining area 74 square inches (477 cm<sup>2</sup>).

**Swing lock** — Mechanically controlled double pawl engages with internal teeth of swing (ring) gear.

**Maximum swing speed** — 4.0 rpm.



Boom/hoist lowering system

Independent, spur gear driven. Precision control boom hoisting and lowering through Speed-o-Matic power hydraulic two-shoe clutches.

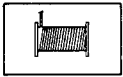

### Boomhoist drum

Grooved, 9" (0.23 m) root diameter, wire rope drum involute splined to shaft.

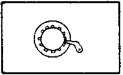

### Boomhoist drum locking pawl

Operator controlled; mechanically applied and released. Locking pawl engages ratchet teeth on flange of boomhoist drum to hold boom at fixed operating radius.



### Boomhoist/lowering clutches

Speed-o-Matic power hydraulic two-shoe clutches; one each for boom hoisting and lowering. 20" (0.51 m) diameter, 5" (0.13 m) face width; effective lining area 212 square inches (1 368 cm<sup>2</sup>).



### Boomhoist brake

One external contracting band brake; automatically spring applied, hydraulically released. Brake 22" (0.56 m) diameter, 3" (76.20 mm) face width; effective lining area 174 square inches (1 123 cm<sup>2</sup>).

**Boomhoist limiting device** — Provided to restrict hoisting boom beyond recommended minimum radius; located on exterior right hand side of operator's cab.



### Electrical system

Battery, 12-volt, 225 ampere hour; either one or two batteries depending on engine. *Optional:* battery lighting system including two sealed beam automotive type adjustable headlights located on cab front roof, one interior cab light, and automotive type wiring. *Optional:* additional 50 watt sealed beam automotive type headlight mounted on boom (three maximum quantity recommended). *Optional:* Onan independent light plant with single cylinder, four cycle, air cooled diesel engine with remote electrical starting, 3000 watt, 120-volt, three-wire, single phase, 60 cycles A.C., including wiring in conduit, interior cab lights, trouble lamp

with cord, and two 300 watt adjustable flood lights on cab front roof. *Optional:* additional 300 watt floodlights available for mounting on cab and boom. **Note:** Independent light plant cannot be furnished in conjunction with magnet generator package or third drum.

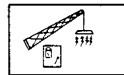

### Magnet generator/control package

*Optional.* 15 or 22.5 kw magnet generator belt driven off engine power take-off shaft. 15 kw magnet generator for use with 230 volt magnets rated at 30 to 73 operating amperes; 22.5 kw magnet generator for use with 230 volt magnets rated at 81 to 115 operating amperes with the 34" (0.86 m) angle boom only. Rheostat, controller, magnet load lift control button on rear drum lever, load drop control button on swing lever, and Rud-O-Matic #636 combination tagline/magnet cable take-up reel.

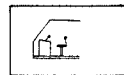

### Operator's cab

Full-vision, equipped with safety glass panels. Operator's door is hinged; front window slides to overhead storage on ball bearing rollers and right window slides open. Standard equipment includes dry chemical fire extinguisher, machinery guards, bubble-type level, and hand grab rails.

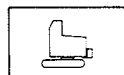

### Elevated operator's cab

*Optional.* 2' (0.61 m), 4' (1.22 m), or 7' (2.13 m) higher than standard cab. Upper cab portion hinged on 2' (0.61 m) cab, removable on 4' (1.22 m) and 7' (2.13 m) cab; hydraulic control lines equipped with quick-disconnect fittings to facilitate folding to rear (or removing) cab portion forward to reduce overall clearance height.

**Optional cab accessories** — Electric windshield wiper for both standard and elevated cabs. Cab heater, defroster fan, and steel vandalism window covers for standard cab only. Sound reduction material in operator's cab for standard and 4' (1.22 m) elevated cabs.

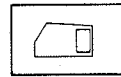

### Machinery cab

Machinery access provided by hinged doors on sides and right front corner; rear doors roll on ball bearing rollers. Cab equipped with roof-top access ladder, electric warning horn, machinery guards, hand grab rails, and skid-resistant finish on roof.

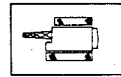

### Catwalks

*Optional* for operator's side or both sides of standard cab; include overhead hand grab rail on sides of cab.

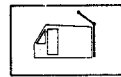

### Gantry

*Standard:* low gantry mounted on revolving upperstructure frame to rear of machinery side housing to support boom suspension system. *Optional:* retractable high gantry required on boom lengths exceeding 60' (18.29 m). Mounted at rear of cab to support boom suspension system; can be raised or lowered by the boomhoist clutches. Also serves to raise counterweight into position or lower it to the ground.

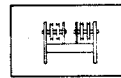

### Gantry bail

Pinned to low gantry frame or retractable high gantry bail links; serves as connection between gantry and boomhoist wire rope reeving. *Standard:* three sheaves mounted on bronze bushings for eight-part boomhoist wire rope reeving. *Optional* for retractable high gantry only: four or five sheaves for ten or twelve-part line. Sheaves for eight or ten-part line mounted on bronze bushings. Sheaves for twelve-part line mounted on anti-friction bearings.



### Counterweight

Removable; held in place by "T" bolts. — Counterweight "A": 14,800 lbs. (6 713 kg) or 13,900 lbs. (6 305 kg) depending on engine used. — Counterweight "AB": 20,000 lbs. (9 072 kg) or 19,100 lbs. (8 664 kg) depending on engine used. **Note:** Refer to capacity charts for counterweight requirements.

**GENERAL INFORMATION ONLY**

**Counterweight removal device** — Power raising and lowering with boomhoist clutches on machines equipped with retractable high gantry.

## Crane booms and jibs

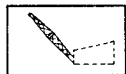

**Angle boom**

Two-piece basic boom 40' (12.19 m) long with open throat top section; 34" (0.86 m) wide, 34" (0.86 m) deep at connections. Alloy steel main chord angles; base section 3" x 3" x 3/8" (76.20 x 76.20 x 9.53 mm); top section and extensions — 3" x 3" x 5/16" (76.20 x 76.20 x 7.94 mm).

**Base section** — 20' (6.10 m) long; boomfeet 1 5/8" (41.33 mm) wide on 38" (0.97 m) centers.

**Boom extensions** — Available in 5', 10', 15' and 20' (1.52, 3.05, 4.57 and 6.10 m) lengths with appropriate length pendants.

**Boom connections** — Standard: pin connections. *Optional:* bolted connections.

**Boom top section** — 20' (6.10 m) long.

**Boompoint machinery** — Heat treated head sheaves, mounted on anti-friction bearings on boompeak shaft. *Standard:* three 17 7/8" (0.45 m) root diameter head sheaves. *Optional:* four 18" (0.46 m) root diameter or two 17 7/8" (0.45 m) root diameter sheaves instead of three; one wide-mouth 18" (0.46 m) root diameter sheave is available for dragline applications.

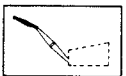

**Angle jib**

Two-piece basic jib 20' (6.10 m) long; 22 3/4" (0.58 m) wide, 18" (0.46 m) deep at connections. Alloy steel main chord angles; base section chords 2" x 2" x 1/4" (50.80 x 50.80 x 6.35 mm); tip section chords 2" x 2" x 3/16" (50.80 x 50.80 x 4.76 mm).

**Base section** — 10' (3.05 m) long; mounted to bracket welded on end boom top section.

**Jib extensions** — Available in 10' (3.05 m) lengths for 30' or 40' (9.14 or 12.19 m) jibs.

**Jib connections** — Bolted.

**Jib tip section** — 10' (3.05 m) long; single peak sheave 15 7/8" (0.40 m) root diameter mounted on anti-friction bearings.



**Jib Mast**

10' (3.05 m) high, mounted on jib base section. Two deflector sheaves mounted on anti-friction bearings for jib load hoist line within the mast. Two equalizer sheaves for jib front stay and jib back staylines mounted to top of mast.

**Jib mast stops** — Telescoping type, spring-loaded; pinned from jib mast to boom top section and from jib mast to jib base section.

**Jib staylines** — Back staylines attached between top of jib mast and base of boom top section; front staylines attached between top of jib mast and peak of jib.

**Boompoint sheave guards** — *Standard:* rigid, round steel rod bolted over top of sheaves and rigid, round steel rods between sheaves. *Optional:* roller-type guards mounted on anti-friction bearings, mounted on brackets beneath sheaves.

**Note:** Roller-type guards do not permit use of center sheave(s), and are not available on boom equipped with jib.



**Boom stops**

Dual tubular boom stops with spring loaded bumper ends: fixed horizontal on cab roof.

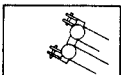

**Boomhoist bridle**

Serves as connection between pendants and boomhoist reeving. Bridle contains 9 1/2" (0.24 m) root diameter sheaves mounted on bronze bushings. Four sheaves for eight-part boomhoist reeving for use with low gantry; retractable high gantry requires either four, five or six sheaves depending on whether using eight, ten or twelve-part boomhoist reeving.

**Deflector rollers** — Heat treated, tubular steel rollers mounted on anti-friction bearings. Required when third drum wire rope passes over crane boompoint. Recommended for long booms and for short booms when load is being handled on front drum wire rope. One roller standard on top side of boom base section. Recommended optional rollers: one roller for boom lengths through 45' (13.72 m); two rollers for boom lengths beyond 45' (13.72 m) through 65' (19.81 m); three rollers for boom lengths beyond 65' (19.81 m) through 85' (25.91 m); four rollers for boom lengths beyond 85' (25.91 m) through 100' (30.48 m).

## Auxiliary equipment



**Boom angle indicator**

*Standard:* pendulum type, mounted on operator's side of boom base section.



**Fairlead**

*Optional:* Full-revolving type with lock, barrel, sheaves, and guide rollers mounted on anti-friction bearings.

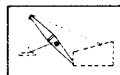

**Tagline**

*Optional:* Rud-O-Matic® model 648; spring wound drum type mounted on crane boom. Rope pull off drum — 90' (27.43 m) from neutral. Morin Tagmaster Model BR — 0 to 100 lbs. (0 - 45.36 kg) adjustable pull; 2,000 lb. (907.20 kg) maximum pull at operator demand.

**GENERAL INFORMATION ONLY**



# Link-Belt® LS-98A lifting crane capacities

PCSA Class 10-103  
Refer to Notes page 3.

**Boom** — angle; 34" (0.86 m) side, 34" (0.86 m) deep with open throat top section, 1 1/8" (28 mm) diameter boom pendants, retractable high or standard low gantry.

**Mounting** — crawler; 9' 6" (2.90 m) gauge, 15' 1" (4.60 m) overall length.

**Counterweights** — refer to chart below.

Attachment	Counterweights							
	"A"				"AB"			
	Engine used				Engine used			
	Caterpillar 3306T		General Motors		Caterpillar 3306T		General Motors	
	Pounds	kilograms	Pounds	kilograms	Pounds	kilograms	Pounds	kilograms
Crane	13,900	6 305	14,800	6 713	19,250	8 732	20,000	9 072
Dragline, clamshell or magnet	13,900	6 305	14,800	6 713	← Not applicable →			

Maximum angle boom or boom + jib machine can lift off ground unassisted — without load. ①②

Standard machine	Counterweight "A"				Counterweight "AB"			
	Boom		Boom + jib		Boom		Boom + jib	
	Feet	meters	Feet	meters	Feet	meters	Feet	meters
Over ends	100	30.48	90 + 40	27.43 + 12.19	100	30.48	90 + 40	27.43 + 12.19
Over sides	100	30.48	80 + 40	24.38 + 12.19	100	30.48	90 + 40	27.43 + 12.19

① Limited to 95% of available stability with machine standing level on firm supporting surface.  
② With 1 1/8" (28 mm) diameter pendants and hook block on ground.

Maximum angle boom or boom + jib machine can lift off ground unassisted<sup>③</sup> and travel with, without load. Based on boom horizontal and minimum travel speed on firm, level supporting surface<sup>④⑤</sup>.

Standard machine	Counterweight "A"				Counterweight "AB"			
	Boom		Boom + jib		Boom		Boom + jib	
	Feet	meters	Feet	meters	Feet	meters	Feet	meters
Over ends	100	30.48	80 + 40	24.38 + 12.19	100	30.48	90 + 40	27.43 + 12.19
Over sides	90	27.43	70 + 40	21.34 + 12.19	100	30.48	80 + 40	24.38 + 12.19

③ With 1 1/8" (28 mm) diameter pendants and hook block on ground.  
④ Limited to 85% of available stability.  
⑤ Hook block carried at boom and jib points. Based on 40-ton (36.28 metric ton), three-sheave, 750 lb. (340.20 kg) hook block, and 6 1/2-ton (5.90 metric ton), single sheave, 140 lb. (63.50 kg) ball with swivel hook.

**GENERAL INFORMATION ONLY**



# LS-98A lifting crane capacities

Refer to Notes page 3.

**Boom** — angle; 34" (0.86 m) side, 34" (0.86 m) deep with open throat top section, 1 1/8" (28 mm) diameter boom pendants, retractable high or standard low gantry.

**Mounting** — crawler; 9' 6" (2.90 m) gauge, 15' 1" (4.60 m) overall length.

**Counterweights** — refer to counterweight chart page 1.

Length	Boom					Counterweight "A"		Counterweight "AB"	
	Radius		Angle	Boom point height <sup>Ⓢ</sup>		Pounds	kilograms	Pounds	kilograms
	Feet	meters	Degree	Feet	meters				
40' (12.19 m)	10	3.05	80.2	44' 10"	13.66	68,800	31 207	80,000	36 287
	11	3.35	78.7	44' 8"	13.61	57,500	26 081	67,000	30 390
	12	3.66	77.2	44' 5"	13.54	49,400	22 407	57,500	26 081
	13	3.96	75.8	44' 2"	13.47	43,200	19 595	50,300	22 815
	14	4.27	74.3	43' 11"	13.39	38,400	17 417	44,800	20 320
	15	4.57	72.8	43' 8"	13.30	34,500	15 648	40,200	18 234
	16	4.88	71.3	43' 4"	13.20	31,300	14 197	36,500	16 556
	17	5.18	69.8	42' 11"	13.09	28,600	12 972	33,400	15 149
	18	5.49	68.2	42' 7"	12.97	26,300	11 929	30,800	13 970
	19	5.79	66.7	42' 2"	12.85	24,400	11 067	28,500	12 927
	20	6.10	65.1	41' 8"	12.71	22,700	10 296	26,500	12 020
	25	7.62	56.9	38' 11"	11.87	16,700	7 574	19,600	8 890
	30	9.14	47.9	35' 1"	10.69	13,100	5 942	15,400	6 985
35	10.67	37.3	29' 8"	9.03	10,700	4 853	12,600	5 715	
40	12.19	23.0	21' 0"	6.41	8,900	4 036	10,600	4 808	
50' (15.24 m)	11	3.35	81.0	54' 10"	16.70	57,300	25 990	66,800	30 299
	12	3.66	79.8	54' 8"	16.65	49,200	22 316	57,300	25 990
	13	3.96	78.7	54' 5"	16.59	43,000	19 504	50,200	22 770
	14	4.27	77.5	54' 3"	16.53	38,100	17 281	44,500	20 184
	15	4.57	76.3	54' 0"	16.46	34,200	15 512	40,000	18 143
	16	4.88	75.1	53' 9"	16.38	31,100	14 106	36,300	16 465
	17	5.18	73.9	53' 6"	16.30	28,400	12 882	33,200	15 059
	18	5.49	72.7	53' 2"	16.21	26,100	11 838	30,500	13 834
	19	5.79	71.5	52' 10"	16.11	24,100	10 931	28,300	12 836
	20	6.10	70.3	52' 6"	16.00	22,400	10 160	26,300	11 929
	25	7.62	64.1	50' 5"	15.36	16,400	7 438	19,300	8 754
	30	9.14	57.5	47' 7"	14.51	12,800	5 805	15,200	6 894
	35	10.67	50.5	44' 0"	13.40	10,400	4 717	12,300	5 579
40	12.19	42.6	39' 3"	11.96	8,600	3 900	10,300	4 672	
50	15.24	20.5	22' 11"	6.99	6,300	2 857	7,600	3 447	
60' (18.29 m)	12	3.66	81.5	64' 9"	19.74	49,000	22 226	57,100	25 900
	13	3.96	80.6	64' 7"	19.69	42,800	19 413	50,000	22 679
	14	4.27	79.6	64' 5"	19.64	37,900	17 191	44,300	20 094
	15	4.57	78.6	64' 3"	19.58	34,000	15 422	39,800	18 052
	16	4.88	77.7	64' 0"	19.52	30,800	13 970	36,000	16 329
	17	5.18	76.7	63' 10"	19.45	28,100	12 745	32,900	14 923
	18	5.49	75.7	63' 7"	19.37	25,800	11 702	30,300	13 743
	19	5.79	74.7	63' 3"	19.29	23,900	10 840	28,000	12 700
	20	6.10	73.7	63' 0"	19.20	22,200	10 069	26,000	11 793
	25	7.62	68.7	61' 4"	18.69	16,200	7 348	19,000	8 618
	30	9.14	63.4	59' 1"	18.01	12,500	5 669	14,900	6 758
	35	10.67	58.0	56' 3"	17.15	10,100	4 581	12,100	5 488
	40	12.19	52.1	52' 9"	16.09	8,400	3 810	10,000	4 535
50	15.24	38.7	42' 11"	13.08	6,000	2 721	7,300	3 311	
60	18.29	18.7	24' 8"	7.51	4,600	2 086	5,600	2 540	
70' (21.34 m)	13	3.96	81.9	74' 9"	22.78	44,300	20 094	51,400	23 314
	14	4.27	81.1	74' 7"	22.73	39,200	17 780	45,600	20 683
	15	4.57	80.3	74' 5"	22.68	35,200	15 966	40,900	18 551
	16	4.88	79.4	74' 3"	22.63	31,900	14 469	37,100	16 828
	17	5.18	78.6	74' 0"	22.57	29,100	13 199	33,800	15 331
	18	5.49	77.8	73' 10"	22.50	26,700	12 110	31,200	14 152
	19	5.79	76.9	73' 7"	22.43	24,700	11 203	28,800	13 063
	20	6.10	76.1	73' 4"	22.36	22,900	10 387	26,800	12 156
	25	7.62	71.8	71' 11"	21.92	16,700	7 574	19,500	8 845
	30	9.14	67.5	70' 1"	21.36	12,900	5 851	15,300	6 939
	35	10.67	63.0	67' 9"	20.65	10,400	4 717	12,300	5 579
	40	12.19	58.3	64' 11"	19.79	8,600	3 900	10,300	4 672
	50	15.24	48.0	57' 5"	17.51	6,200	2 812	7,500	3 401
60	18.29	35.7	46' 3"	14.11	4,600	2 086	5,700	2 585	
70	21.34	17.3	26' 3"	8.00	3,600	1 632	4,500	2 041	
80' (24.38 m)	15	4.57	81.5	84' 6"	25.77	35,000	15 875	40,700	18 461
	16	4.88	80.8	84' 5"	25.72	31,700	14 378	36,900	16 737
	17	5.18	80.0	84' 3"	25.67	28,900	13 108	33,600	15 240
	18	5.49	79.3	84' 0"	25.61	26,500	12 020	30,900	14 016
	19	5.79	78.6	83' 10"	25.55	24,400	11 067	28,600	12 972
	20	6.10	77.9	83' 8"	25.49	22,700	10 296	26,500	12 020
	25	7.62	74.2	82' 5"	25.11	16,500	7 484	19,300	8 754
	30	9.14	70.4	80' 9"	24.62	12,700	5 760	15,000	6 803
35	10.67	66.6	78' 10"	24.02	10,200	4 626	12,100	5 488	

Ⓢ Measured vertically from boom head sheave to ground.

# LS-98A lifting crane capacities — continued

Refer to Notes below.

Length	Boom					Counterweight "A"		Counterweight "AB"	
	Radius		Angle	Boom point height <sup>①</sup>		Pounds	kilograms	Pounds	kilograms
	Feet	meters	Degree	Feet	meters				
80' (24.38 m)	40	12.19	62.6	76' 5"	23.30	8,300	3 764	10,000	4 535
	50	15.24	54.2	70' 3"	21.42	5,900	2 676	7,200	3 265
	60	18.29	44.7	61' 9"	18.81	4,400	1 995	5,400	2 449
	70	21.34	33.3	49' 5"	15.05	3,300	1 496	4,200	1 905
	80	24.38	16.2	27' 8"	8.44	2,500	1 133	3,300	1 496
90' (27.43 m)	16	4.88	81.8	94' 6"	28.80	31,500	14 288	36,700	16 646
	17	5.18	81.2	94' 4"	28.76	28,700	13 018	33,400	15 149
	18	5.49	80.5	94' 2"	28.71	26,300	11 929	30,700	13 925
	19	5.79	79.9	94' 0"	28.66	24,200	10 976	28,400	12 882
	20	6.10	79.2	93' 10"	28.60	22,400	10 160	26,300	11 929
	25	7.62	76.0	92' 9"	28.26	16,200	7 348	19,100	8 663
	30	9.14	72.7	91' 4"	27.84	12,400	5 624	14,800	6 713
	35	10.67	69.3	89' 7"	27.31	9,900	4 490	11,900	5 397
	40	12.19	65.8	87' 6"	26.68	8,100	3 674	9,800	4 445
	50	15.24	58.6	82' 3"	25.08	5,700	2 585	7,000	3 175
	60	18.29	50.8	75' 2"	22.92	4,100	1 859	5,200	2 358
	70	21.34	42.0	65' 8"	20.02	3,000	1 360	3,900	1 769
	80	24.38	31.4	52' 3"	15.94	2,300	1 043	3,000	1 360
90	27.43	15.2	29' 1"	8.86	1,700	771	2,400	1 088	
100' (30.48 m)	18	5.49	81.5	104' 4"	31.79	26,100	11 838	30,500	13 834
	19	5.79	80.9	104' 2"	31.75	24,000	10 886	28,200	12 791
	20	6.10	80.3	104' 0"	31.70	22,200	10 069	26,100	11 838
	25	7.62	77.4	103' 0"	31.40	16,000	7 257	18,900	8 572
	30	9.14	74.4	101' 9"	31.01	12,200	5 533	14,600	6 622
	35	10.67	71.4	100' 3"	30.55	9,700	4 399	11,600	5 261
	40	12.19	68.4	98' 5"	29.99	7,800	3 538	9,500	4 309
	50	15.24	62.1	93' 9"	28.58	5,400	2 449	6,700	3 039
	60	18.29	55.4	87' 8"	26.73	3,900	1 769	4,900	2 222
	70	21.34	48.1	79' 10"	24.32	2,800	1 270	3,700	1 678
	80	24.38	39.8	69' 5"	21.16	2,000	907	2,800	1 270
	90	27.43	29.7	55' 0"	16.77	1,400	635	2,100	952
	100	30.48	14.5	30' 5"	9.26	—	—	1,500	680

① Measured vertically from center of boom head sheave to ground.

## Notes — lifting crane capacities

- Capacities included in this chart are the maximum allowable, and are based on machine standing level on firm supporting surface under ideal job conditions.
- Capacities are based on 75% of minimum tipping loads unless marked with an asterisk (\*).
  - Asterisk indicates capacities based on factors other than those which would cause a tipping condition.
- Capacities are based on freely suspended loads and make no allowance for such factors as the effect of wind, sudden stopping of loads, supporting surface conditions, and operating speeds.
- Operator must reduce load ratings to take such conditions into account. Deduction from rated capacities must be made for weight of hook block, weighted ball/hook, sling, spreader bar, or other suspended gear.
- For lifting rated loads with booms longer than 60' (18.29 m) retractable high gantry must be used in the elevated position. Standard low gantry or retractable high gantry in lowered position may be used for lifting loads with booms up to 60' (18.29 m).
- Least stable position is over the side.
- Main boom length without jib must not exceed 100' (30.48 m).
- Jib length must not exceed 40' (12.19 m).
- Jib must not be mounted on boom longer than 90' (27.43 m).
- For lifting loads greater than 67,200 lbs. (30 482 kg), up to 80,000 lbs. (36 288 kg) five parts of 3/4" (19 mm) Type "N" wire rope are required.
- These capacities apply only to the machine as originally manufactured and normally equipped by FMC Corporation, Cable Crane and Excavator Division.

**GENERAL INFORMATION ONLY**

## LS-98A boom/jib working ranges

**Boom** — angle; 34" (0.86 m) wide, 34" (0.86 m) deep with open throat top section 1 1/8" (28 mm) diameter Type "N" boom pendants, retractable high gantry.

**Jib** — angle; 22 3/4" (0.58 m) wide, 18" (0.46 m) deep.

**Mounting** — crawler; 9' 6" (2.90 m) gauge, 15' 1" (4.60 m) overall length.

**Counterweights** — refer to counterweight chart page 1.

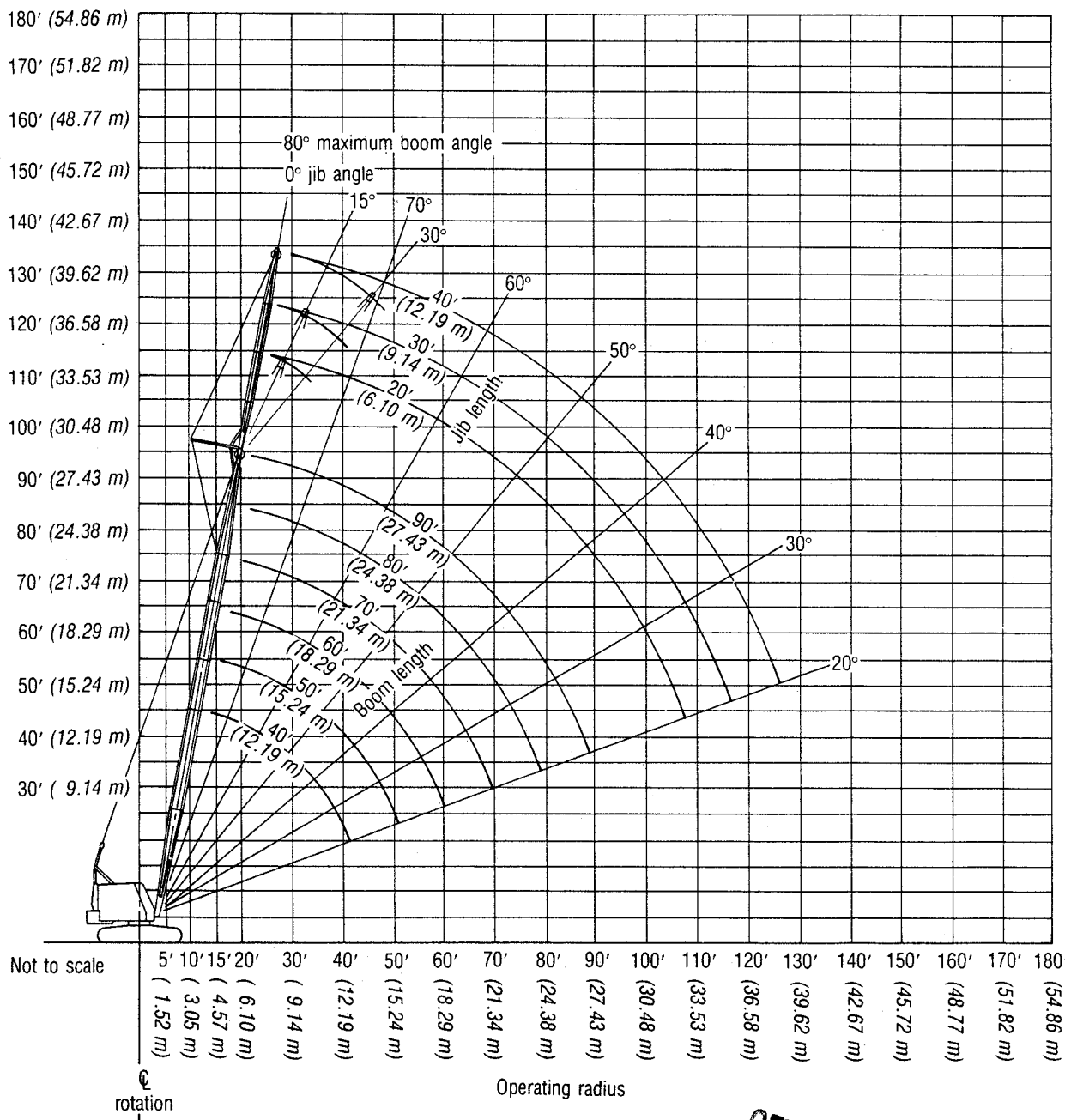

GENERAL INFORMATION ONLY

# LS-98A dragline/clamshell/magnet capacities

Refer to Notes below.

**Boom** — angle; 34" (0.86 m) side, 34" (0.86 m) deep with open throat top section, 1½" (28 mm) diameter boom pendants, retractable high or standard low gantry.

**Mounting** — crawler; 9' 6" (2.90 m) gauge, 15' 1" (4.60 m) overall length.

**Counterweights** — based on engine used: 13,900 lbs. (6 305 kg) or 14,800 lbs. (6 713 kg) counterweight "A".

Length	Boom					Dragline		Clamshell/magnet	
	Radius		Angle	Boom point height <sup>Ⓞ</sup>		Pounds	kilograms	Pounds	kilograms
	Feet	meters	Degree	Feet	meters				
40' (12.19 m)	10	3.05	80.2	44' 10"	13.66			13,600	6 168
	11	3.35	78.7	44' 8"	13.61			13,600	6 168
	12	3.66	77.2	44' 5"	13.54			13,600	6 168
	13	3.96	75.8	44' 2"	13.47			13,600	6 168
	14	4.27	74.3	43' 11"	13.39			13,600	6 168
	15	4.57	72.8	43' 8"	13.30			13,600	6 168
	16	4.88	71.3	43' 4"	13.20			13,600	6 168
	17	5.18	69.8	42' 11"	13.09			13,600	6 168
	18	5.49	68.2	42' 7"	12.97			13,600	6 168
	19	5.79	66.7	42' 2"	12.85			13,600	6 168
	20	6.10	65.1	41' 8"	12.71			13,600	6 168
	25	7.62	56.9	38' 11"	11.87	11,800	5 352	13,600	6 168
	30	9.14	47.9	35' 1"	10.69	11,800	5 352	11,800	5 352
	35	10.67	37.3	29' 8"	9.03	10,700	4 853	9,600	4 354
40	12.19	23.0	23.0	21' 0"	6.41	8,900*	4 036*	8,000	3 628
50' (15.24 m)	11	3.35	81.0	54' 10"	16.70			13,600	6 168
	12	3.66	79.8	54' 8"	16.65			13,600	6 168
	13	3.96	78.7	54' 5"	16.59			13,600	6 168
	14	4.27	77.5	54' 3"	16.53			13,600	6 168
	15	4.57	76.3	54' 0"	16.46			13,600	6 168
	16	4.88	75.1	53' 9"	16.38			13,600	6 168
	17	5.18	73.9	53' 6"	16.30			13,600	6 168
	18	5.49	72.7	53' 2"	16.21			13,600	6 168
	19	5.79	71.5	52' 10"	16.11			13,600	6 168
	20	6.10	70.3	52' 6"	16.00			13,600	6 168
	25	7.62	64.1	50' 5"	15.36			13,600	6 168
	30	9.14	57.5	47' 7"	14.51	11,800	5 352	11,500	5 216
	35	10.67	50.5	44' 0"	13.40	10,400	4 717	9,400	4 263
	40	12.19	42.6	39' 3"	11.96	8,600	3 900	7,700	3 492
50	15.24	20.5	22' 11"	6.99	6,300*	2 857*	5,700	2 585	
60' (18.29 m)	12	3.66	81.5	64' 9"	19.74			13,600	6 168
	13	3.96	80.6	64' 7"	19.69			13,600	6 168
	14	4.27	79.6	64' 5"	19.64			13,600	6 168
	15	4.57	78.6	64' 3"	19.58			13,600	6 168
	16	4.88	77.7	64' 0"	19.52			13,600	6 168
	17	5.18	76.7	63' 10"	19.45			13,600	6 168
	18	5.49	75.7	63' 7"	19.37			13,600	6 168
	19	5.79	74.7	63' 3"	19.29			13,600	6 168
	20	6.10	73.7	63' 0"	19.20			13,600	6 168
	25	7.62	68.7	61' 4"	18.69			13,600	6 168
	30	9.14	63.4	59' 1"	18.01			11,300	5 125
	35	10.67	58.0	56' 3"	17.15	10,100	4 581	9,100	4 127
	40	12.19	52.1	52' 9"	16.09	8,400	3 810	7,600	3 447
	50	15.24	38.7	42' 11"	13.08	6,000	2 721	5,400	2 449
60	18.29	18.7	24' 8"	7.51	4,600*	2 086*	4,100	1 859	

<sup>Ⓞ</sup>Measured vertically from center of boom head sheave to ground.

## Notes — dragline/clamshell/magnet capacities

- Capacities shown are maximum recommended by PCSA Standard No. 1, and should be considered as applicable for ideal job conditions. Allowances must be made for soft or uneven supporting surface, rapid cycle operation, bucket suction, or other unfavorable conditions which may require smaller buckets or magnets for most efficient operation. Weights of buckets, magnet, etc., plus load, should not exceed these capacities.
- Dragline capacities do not exceed 75% of minimum tipping loads; clamshell and magnet capacities do not exceed 67½% of minimum tipping loads.
- Dragline operation with boom angle less than 35° is not recommended.
- Maximum boom length permitted for dragline/clamshell/magnet operation is 60' (18.29 m).
- Refer also to Notes — lifting crane capacities, page 3.

**GENERAL INFORMATION ONLY**



## LS-98A working areas

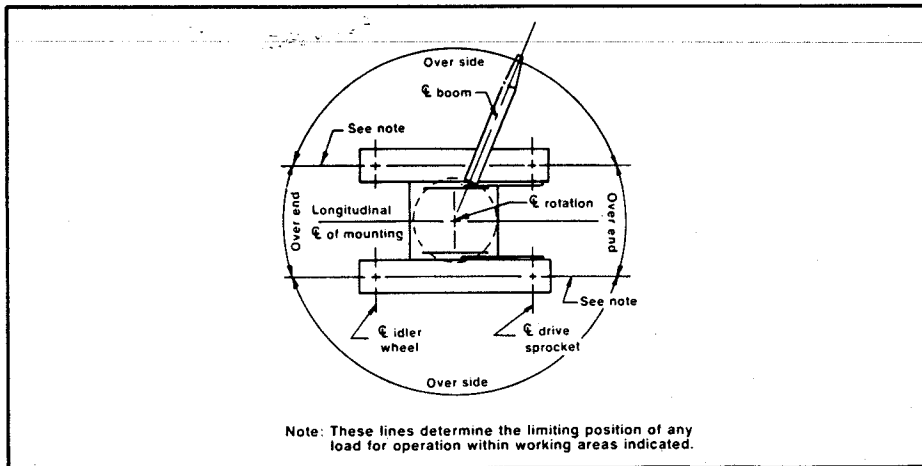

GENERAL INFORMATION ONLY

We are constantly improving our products and therefore reserve the right to change designs and specifications.



**FMC Corporation Cable Crane & Excavator Division Cedar Rapids Iowa 52406**  
Link-Belt® cranes/excavators manufactured in: Cedar Rapids Iowa • Lexington & Bowling Green Kentucky • Ontario Canada • Milan Italy • Queretaro Mexico & Nagoya Japan (under license)