



224B

EXCAVATOR

Maximum:

Lift Capacity with 2800 mm/ 9'2" Stick
at Ground Level 4.5 m/ 15' Out
Over Front and Side 8030 kg/ 17,700 lb
Digging Depth 6510 mm/ 21'4"
Reach at Ground Level 9610 mm/ 31'6"

■ Flywheel Power.....101 kW/ 135 hp
■ Operating Weight
.....20 000 to 22 500 kg/ 44,000 to 49,500 lb
■ General Purpose Bucket Capacities
.....520 to 1170 l/ 0.67 to 1.53 yd³

Machine shown may include optional equipment.



FEATURES

Operator's Compartment

Spacious, efficient design provides day-long comfort and superior operating ease for maximum productivity.

- **Wide -- 920 mm/ 36.22" inside -- cab** for excellent operator comfort.
- **Ventilation system** circulates pressurized, filtered air through cab.
- **Pilot-operated joysticks** allow short-throw, fingertip operation for precise control.
 - Oblique joystick movement simultaneously actuates more than one function.
- **Single-lever control** simultaneously sets oscillating axle lock, four-wheel brakes and parking brake.
 - Brakes and the axle lock also can be set individually.
- **Pedal-operated swing brake** has a brake lock detent for operator convenience.
 - Swing brake also applies automatically after engine is shut off.
- **Retracting front window** stores integrally under cab roof.
 - Transparent skylight enhances overhead visibility and cab lighting.
- **Break-resistant, polycarbonate side and rear windows** used in Western Hemisphere.
- **Suspension seat is fully adjustable** -- up, down, forward, backward, backrest angle and to operator's weight -- for shift-long comfort.
 - Seat adjusts in relation to hand controls.
 - Both move as a unit to position operator for optimum steering wheel and pedal reach.
- **Exceptionally low sound levels.**
 - Less distraction for operator and spectators.
 - Easier communication with workers in the trench.

Cat 3116T Engine

High-tech, six-cylinder engine is designed to provide outstanding performance, reliability and fuel efficiency.

- **Turbocharged for increased performance and efficiency** ... especially at high altitudes — up to 3800 meters/ 12,500 feet.
- **Unit injector fuel system** ... provides individually metered, high-pressure, direct injection of fuel for maximum efficiency.
- **Four-stroke-cycle design** ... uses longer power strokes for more complete fuel combustion and efficiency.
- **High displacement-to-power ratio and low RPM operation** ... ensure long life and exceptional reliability.

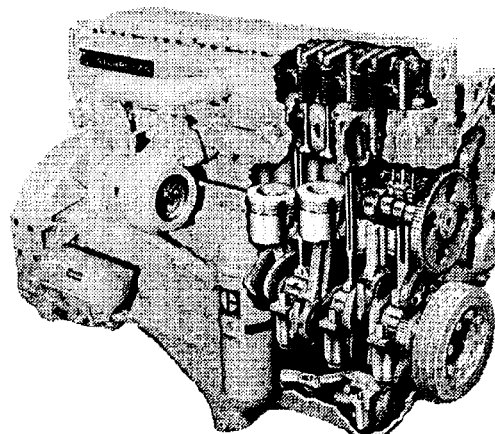

Hydraulic System

Advanced, load-sensing hydraulics redefine productivity and efficiency.

One-pump system

- **A single, main, variable-flow, axial-piston pump** powers the implement, travel and swing functions.
- **Simultaneous proportioned operation** for all functions, including travel, decreases cycle times.
- **O-ring face seals** and SAE four-bolt flanges provide superior sealing of hydraulic hose, tube and port connections for a dry machine.

Power selector

- **Two settings -- light (I) and standard (II)** -- let the operator choose the best hydraulic power range for the job.
 - Light setting is used for easier working conditions or precision grading applications. It provides the best fuel economy.
 - Standard setting is used in normal or heavy work applications.

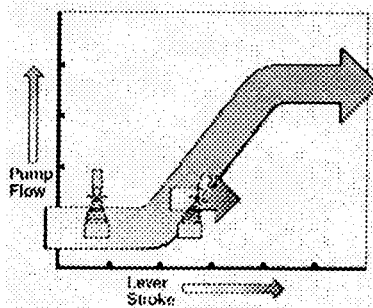

Load-sensing feature

- **System reduces pump flow** to a minimum when joysticks and travel controls are in neutral ... cutting fuel consumption, extending pump life.
- **Pump flow increases** in direct proportion with lever movement ... operator has precise control from feathering to full force.

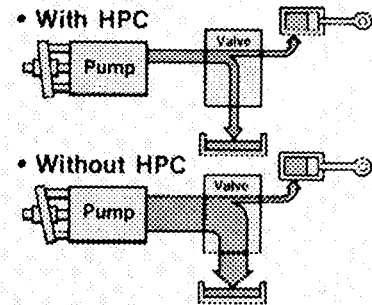

High-pressure cut-off

- **System reduces pump flow** to a minimum before hydraulic pressure reaches relief valve setting.
 - **Reduced flow conserves fuel** ... prevents hydraulic oil deterioration from high system temperatures.
 - **Relief valve noise decreases**, increases pump life.

Undercarriage

Wheel undercarriage offers fast travel on and between job sites.

- **Hydrostatic, four-wheel drive system** with on-the-go shifting.
- **Two forward and reverse speed ranges** -- work and travel.
- **Overspeed valve** limits downhill speeds in forward and reverse.
- **Downshift inhibitor** prevents transmission from downshifting when travel speeds are too high.
- **Creeper speed available.**
 - Allows precise travel control under heavy loads.
 - Permits low travel speeds while maintaining full engine RPM for hydraulic functions.
- **Four-wheel, hydraulically actuated, oil-disc brakes.**
 - Pedal controlled and fully locking.
 - Maintenance free and completely enclosed in the final drive of each hub unit.
- **Blue light** in center of steering wheel alerts operator when the upperstructure is within 60° of center over the fixed rear axle.
- **Oscillating front axle** helps keep all wheels on the ground.
 - Provides maximum traction, smoother ride.
 - Lever in cab hydraulically locks axle for a solid work platform ... improves over-the-side stability by one-third.
- **Excellent ground clearance** - 340 mm/ 13.4"
- **Superior lifting stability** in comparison to track-type units when outriggers are used.
 - Rear outriggers are standard.
 - Front outriggers (second set) is optional.
 - Optional individual outrigger controls allow operator to level machine from cab.

SPECIFICATIONS



Engine

Flywheel power at 2000 RPM: **101 kW/135 HP**
(Kilowatt (kW) is the International System of units equivalent to horsepower.)

Net power at the flywheel is based on SAE J1349 standard conditions of 25°C/77°F and 100 kPa/29.61" Hg. Fuel is 35 API (15.6°C/60°F) gravity having and LHV of 42 780 kJ/kg (18,390 Btu/lb) when used at 29.4°C/85°F and weighing 838,9 g/L (7.001 lb/U.S. gal). Engine is equipped with fan, air cleaner, alternator, water pump, fuel pump, muffler and lubricating oil pump. No derating is required up to 3800 m/12,500 ft altitude.

Cat four-stroke-cycle, 3116 turbocharged diesel engine with six cylinders, 105 mm/4.13" bore, 127 mm/5.0" stroke and 6.6 liters/**403 cu. in.** displacement.

Direct-injection fuel system with an individual, adjustment-free unit injector for each cylinder. Cam-ground and tapered, aluminum-alloy pistons have three rings each and are oil cooled. Connecting rods are tapered.

Uniflow cylinder head design eliminates crossover manifold piping. Internal fuel, oil and water passages used instead of external lines. Deep-skirted, cast cylinder block. Induction-hardened, forged crankshaft. Steel camshaft is fully journaled at every block bulkhead. Oscillating roller followers and short pushrods for precision engine timing. Two alloy-steel valves per cylinder.

Direct-electric, 24-volt starting system with a 55-amp alternator and two 12-volt, 105-amp-hour batteries.



Hydraulic System

Single, variable-displacement, axial-piston pump powers the boom, stick, bucket, swing and travel circuits. Load-sensing system provides the required flow rate to the system or to a single circuit.

Output of the pump at 2,000 RPM and 13 500 kPa/**1960 psi**.....330 liters/min/**87.18 GPM**
Relief valve setting.....32 000 kPa/**4640 psi**

Cylinders	Bore and Stroke	Force(kN/ lb)
Boom (2)	139.8 x 870 mm 5.5" x 34.25"	2 x 490/ 110,200
Stick (1)	139.8 x 1265 mm 5.5" x 49.8"	490/ 110,200
Bucket (1)	127.1 x 1040 mm 5.0" x 40.9"	405/ 91,200

All cylinders have rod- and head-end snubbers to cushion bottoming impact. A check valve in the head-end boom circuit prevents load drift, when activated by a switch on the operator's console.

The hydraulic oil cooling circuit has a thermostatically controlled, hydraulically driven fan.



Transmission

Fully hydrostatic, all-wheel drive with variable-displacement, piston motor. Forward and reverse speed and direction are controlled by foot pedals on the right side of the steering column. On-the-go shifting is permitted.

The transmission is equipped with a downshift governor that prevents high-to-low speed shifts until a lower, pre-set ground speed is reached. An overspeed valve limits downhill travel speeds in both forward and reverse.

The left armrest must be raised to start the engine. Raising the armrest also neutralizes all travel and hydraulic functions except steering.

Speeds (forward and reverse)	km/MPH
Work	0 - 5/ 0 - 3.1
Travel	0 - 20.0/ 0 - 12.4
Optional creeper (work range only)	0 - 2.3/ 0 - 1.4
Gradeability (with standard 10.00 - 20 tires)	70%



Brakes

Service: Fully hydraulic, multiple, oil-disc brakes on all four wheels. Engine-mounted pump supplies the system, which has three pre-charged, nitrogen-filled accumulators. A drop in system pressure below 10 000 kPa/ **1450 psi** actuates a warning light on the console and an audible alarm. The brakes can be locked during excavator operation.

Parking: Spring-applied, hydraulically released shoe brake is mounted between the drive shaft sections. Functions as an additional holding brake during excavator operation.

Secondary: Uses parking brake. Operator manually modulates the brake during application. A separate accumulator keeps the secondary brake independent of the service brake.



Steering

Fully hydraulic steering system is powered by separate pump mounted on the main pump housing. Supplemental steering capability is actuated by the steering wheel.

Steering angle	35°
(inner wheel, each direction)	
Turning circle diameter	13.2 m/ 43'4"
(centerline, outside dual tire)	
Vehicle clearance turning circle:	
One-piece boom,	
equipment folded	17.9 m/ 58'9"
Two-piece boom,	
foreboom fully retracted	
in upper position	15.1 m/ 49'6"



Controls

Two pilot-operated joysticks control the boom, stick, bucket and swing functions. Push button switches on top of the joysticks activate solenoid valves that control attachment options such as ditch-cleaning bucket tilt, or clamshell or grapple rotation.

Right lever: Move forward and backward to lower and raise the boom. Move right and left to control the bucket curl and dump, or to open and close a clamshell.

Left lever: Move forward and backward to move the stick out and in. Move right and left to swing right and left.

Oblique movement of either lever operates two functions simultaneously.

The service brake pedal is located to the right of the steering column. Forward and reverse travel and speed are controlled by two foot pedals located to the right of the service brake pedal.

The operator can control swing deceleration two ways. Moving the swing joystick lever in the opposite direction will reverse the flow and slow the swing. Or, applying the swing brake -- the left pedal -- will slow the swing. The swing brake can be locked by pushing the pedal until the latch engages. To release the brake, the operator pushes the pedal until his foot touches the latch.

The left armrest raises for easy entry and exit. Raising the armrest neutralizes all control functions except steering. The armrest must be raised to start the machine.



Axles and Final Drives

All-wheel drive with conventional differentials and planetary reduction final drives. The front steering axle oscillates $\pm 8.5^\circ$ for excellent stability on rough terrain. The operator can lock the axle in any position of oscillation from the cab.

Ground clearance.....	340 mm/13.4"
(with 10.00 - 20 tires)	
Axle load capacity.....	38 tonnes/ 41.9 tons



Swing Mechanism

The swing drive consists of a piston-type hydraulic motor with combination spur/planetary reduction gearing to pinion. A spring-applied, hydraulically released, wet-disc brake is mounted on the swing drive housing. The swing gear has external teeth, and the swing bearing is a ball-type assembly.

The operator can modulate the swing brake (left pedal) to reduce swinging of a clamshell or a suspended load. The brake can lock the upperstructure in any position. Two pin-type locks -- 180° apart -- can be engaged to secure the upperstructure and undercarriage for travel. The operator engages either of the locks from the cab.

Swing speed at rated engine speed.....	8.0 RPM
--	---------



Tires

New, dual pneumatic 10.00 - 20 tires are standard. Optional tires available: 11.00 - 20; solid rubber 10.00 - 20; single pneumatic 18.00 - 19.5 and 18.00 - 22.5. Recaps and special brands also are available.

SPECIFICATIONS



Service Refill Capacities

	Liters	U. S. Gallons
Fuel tank	330	87.2
Cooling system	30.0	7.9
Hydraulic system (includes tank)	390	103.0
Hydraulic tank	330	87.2
Engine oil	15.0	4.0
Rear axle housing, differential and transmission	13.5	3.6
Front steering axle and differential	10.5	2.8
Final drives (each)	2.5	0.7



Weight

Shipping: Includes one-piece boom, 2800 mm/ 9'2" stick, 910 mm/ 36" general purpose bucket, 10.00 - 20 12 PR dual pneumatic tires, front and rear outriggers and 10% fuel load.....21 250 kg/ 46,850 Lb
Operating: Shipping weight plus 50% fuel load and operator.....21 440 kg/ 47,170 Lb

Approximate weight changes for commonly used attachments.

	Kg	Lb
Two-piece boom	+240	+529
1800 mm/ 5'11" stick	- 180	- 397
2300 mm/ 7'7" stick	- 90	- 198
4000 mm/ 13'2" stick	+544	+1,200
Rear outriggers only	-1175	-2,591
FOPS	+95	+210



Dimensions (approximate)

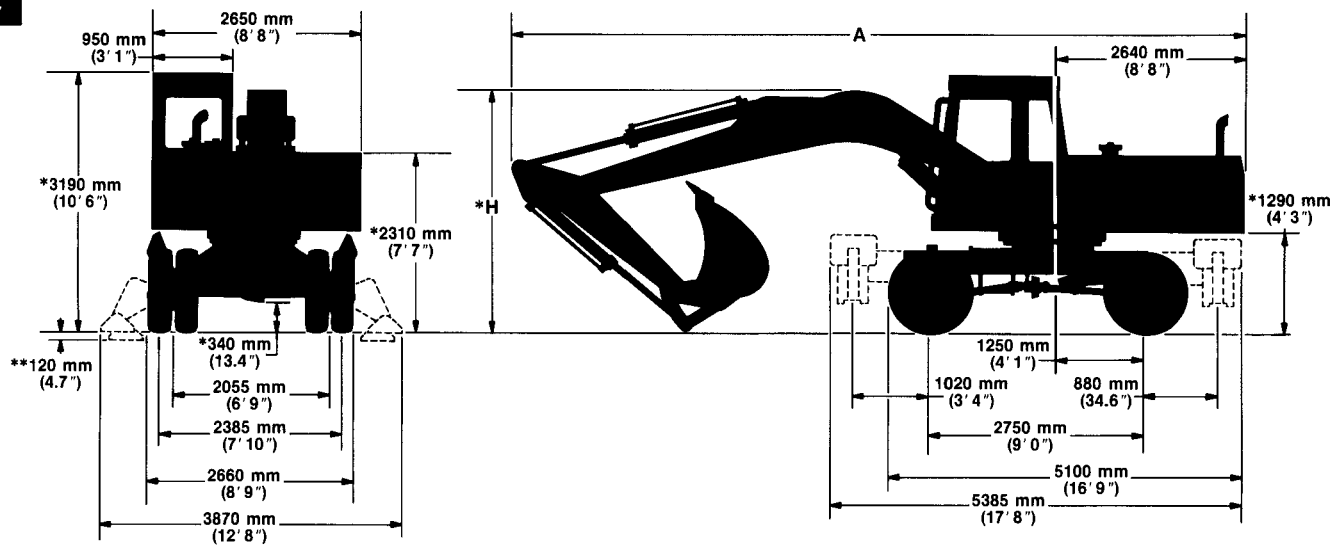

Dimensions shown are for machine equipped with 10.00-20 tires.

- * With 11.00 - 20 or 18.00 - 19.5 tires, increase vertical dimensions marked with one asterisk by 10 mm/ 0.4".
With 18.00 - 22.5 tires, increase vertical dimensions by 55 mm/ 2.16".
- **With 11.00 - 20 or 18.00 - 19.5 tires, decrease vertical dimensions marked with two asterisks by 10 mm/ 0.4".
With 18.00 - 22.5 tires, decrease vertical dimensions by 55 mm/ 2.16".

Transport Dimensions

(machine equipped with one-piece boom)

Stick mm/ ft. in.	Rear Outriggers				Front and Rear Outriggers			
	A		H		A		H	
	mm	ft. in.	mm	ft. in.	mm	ft. in.	mm	ft. in.
1800/ 5'11"	9340	30'8"	3430	11'3"	9340	30'8"	3430	11'3"
2300/ 7'7"	9340	30'8"	3430	11'3"	9340	30'8"	3430	11'3"
2800/ 9'2"	9340	30'8"	3340	10'11"	9280	30'5"	3620	11'11"
4000/ 13'2"	9080	29'9"	3950	13'	8560	28'1"	4780	15'8"



Standard Equipment

Note: Standard and optional equipment may vary. Consult your Caterpillar dealer for specifics.

Alarm, travel with operator-controlled delayed shut-off for long-distance travel (Western Hemisphere only).

Cab, resiliently mounted, sound-suppressed with: pressurized, filtered air circulation system; break-resisitant, polycarbonate skylight; two-piece front window with five open positions and integral overhead storage; tinted, break-resistant

polycarbonate side and rear windows (Western Hemisphere); rear window third exit; fully adjustable suspended seat; floor mat; literature pocket; cigarette lighter; ash tray; bottle rack; coat hanger; and provision for radio installation.

Counterweight, 3350 kg/ **7385 lb.**

Horn, signaling/warning.

Lights:

Cab interior.

Roading system suitable for travel on public roads in most countries.

Mirrors, rear view.

Outriggers, rear.

Power selector.

Storage box (on upperstructure).

Swing pinion protection.

Tires, dual pneumatic 10.00 - 20.

Tool kit.

Wheel chocks.

Windshield washer (Western Hemisphere only) and wipers.



Optional Equipment

Alarm, travel (standard in Western Hemisphere only).

Backhoe sticks:

1800 mm/ **5'11"**

2300 mm/ **7'7"**

2800 mm/ **9'2"**

4000 mm/ **13'2"**

Beacon, rotating.

Booms:

One piece.

Two piece.

Buckets:

General Purpose

710 mm/ **28"**

810 mm/ **32"**

910 mm/ **36"**

1010 mm/ **40"**

1210 mm/ **48"**

1410 mm/ **56"**

Rock

760 mm/ **30"**

1010 mm/ **40"**

Ditch-Cleaning
(hydraulically tilting)

2000 mm/ **79"**

2300 mm/ **91"**

Clamshell bucket diverter valve.

Creeper speed (low gear only).

Falling Object Protective Guard (FOPG) mounts on top of cab.

Gauge, pilot circuit pressure.

Guards:

Headlight.

Swing gear tooth.

Vandalism, front window.

Heater, cab (engine hot water).

Horn, additional warning (air-operated).

Hydraulic circuits, auxiliary.

Hydraulic hammers, with or without blow rate adjustment (contact your Caterpillar dealer).

Hydraulic hammer installation arrangement for short, medium and long sticks (controls and lines installed).

Indicator, load.

Lights:

Engine compartment.

Working, boom mounted (2).

Working rear (1).

Mirror, for view across lower front of cab.

Outriggers, front.

Pump, electric refueling.

Radiator door, locking.

Radio.

Rain/sun visor, outside, top front window.

Spacer rings, rubber, for use between dual tires.

Starting aid, ether.

Storage box, undercarriage-mounted.

Supplemental steering, battery powered.

Tilting device, for ditch-cleaning bucket.

Tires (see page 5).

Valves, lowering, boom and stick.

Windshield washer (standard in Western Hemisphere).

General Purpose Bucket Working Ranges

(Machine is equipped with one-piece boom and 10.00 - 20 tires.)

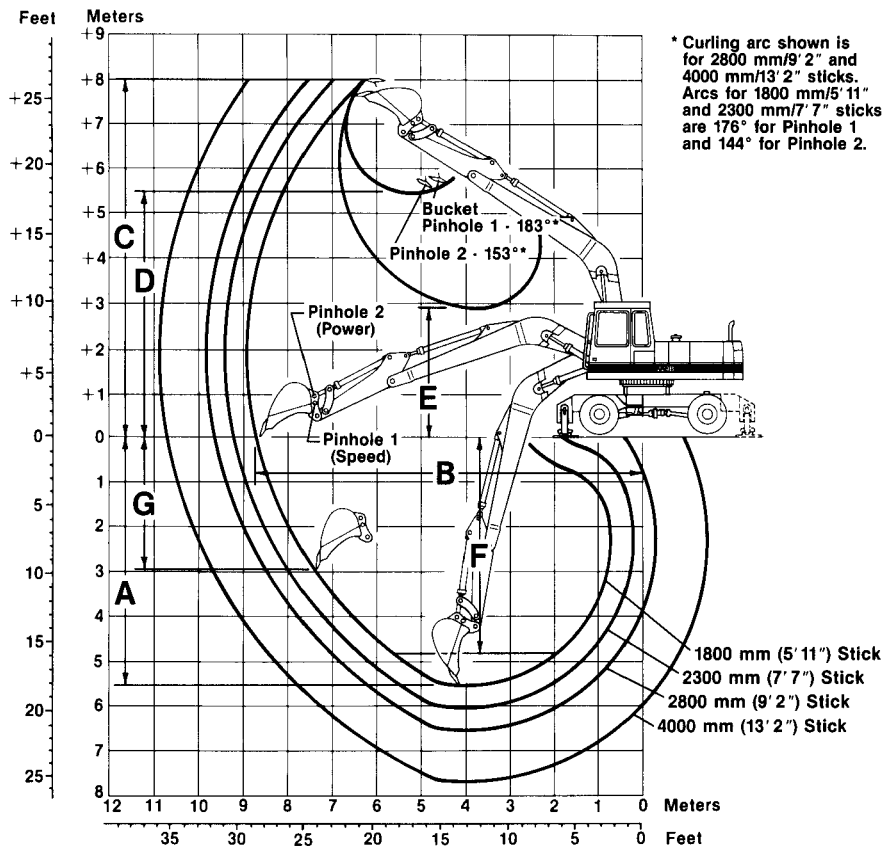

Stick	1800 mm/5'11"	2300 mm/7'7"	2800 mm/9'2"	*4000 mm/13'2"
A Maximum digging depth	5523 mm/18'1"	6025 mm/19'9"	6510 mm/ 21'4"	7710 mm/ 25'4"
B Maximum reach at ground level	8763 mm/ 28'9"	9237 mm/ 30'3"	9610 mm/ 31'6"	10 750 mm/ 35'3"
C Overall height at end of dump	8070 mm/ 26'6"	8297 mm/ 27'3"	8092 mm/ 26'7"	8490 mm/ 27'10"
D Maximum loading height	5523 mm/ 18'1"	5728 mm/ 18'10"	5679 mm/ 18'8"	6070 mm/ 19'11"
E Minimum loading height	2922 mm/ 9'7"	2426 mm/ 7'11"	1940 mm/ 6'4"	740 mm/ 2'5"
F Digging depth at 2440 mm/ 8' flat floor	4848 mm/ 15'11"	5379 mm/ 17'8"	5886 mm/ 19'4"	7131 mm/ 23'5"
G Maximum vertical wall digging depth	2940 mm/ 9'8"	3513 mm/ 11'6"	2980 mm/ 9'9"	4000 mm/ 13'2"

*Extended Reach 4000 mm/ 13'2" Stick must not be used with hammers.

SPECIFICATIONS

Buckets

Caterpillar offers three types of buckets for the 224B Excavator -- general purpose, rock and ditch cleaning. The **general purpose buckets** are equipped with weld-on tooth adapters. Tips are required. And the buckets have two linkage positions -- **power**, for maximum breakout force and **speed**, for faster work

cycles. Cat's heavy duty **rock buckets**, like the general purpose buckets, are equipped with weld-on tooth adapters, and tips are required. The **ditch-cleaning bucket** -- available in two widths -- is hydraulically tilted and not equipped with teeth.

Bucket Type*	Cutting Width		SAE Capacity Heaped		Weight With Teeth		Number of Teeth
	mm	in.	liters	yd ³	kg	lb.	
General Purpose	710	28	520	0.67	530	1,165	3
	810	32	610	0.79	590	1,300	4
	910	36	700	0.91	615	1,355	4
	1010	40	790	1.03	645	1,425	4
	1210	48	980	1.28	745	1,640	5
	1410	56	1170	1.53	845	1,865	5
Rock	760	30	650	0.85	680	1,500	3
	1010	40	920	1.21	820	1,805	4
Ditch-Cleaning (hydraulically tilted)	2000	79	720	0.94	710	1,565	--
	2300	91	620	0.80	550	1,210	--

*Other sizes and types of buckets are available on a made-to-order basis. Consult your Caterpillar dealer for specifics.

Maximum Breakout Forces

Stick	1800 mm/ 5'11"	2300 mm/ 7'7"	2800 mm/ 9'2"	4000 mm/ 13'2"
Stick	120.3 kN/ 27,034 lb	98.1 kN/ 22,045 lb	87.4 kN/ 19,640 lb	67.8 kN/ 15,236 lb
Bucket pinhole 1*	127.3 kN/ 28,607 lb	127.3 kN/ 28,607 lb	123.5 kN/ 27,753 lb	123.5 kN/ 27,753 lb
Bucket pinhole 2*	156.1 kN/ 35,079 lb	156.1 kN/ 35,079 lb	149.0 kN/ 33,483 lb	149.0 kN/ 33,483 lb

*Pinhole 1 gives the highest bucket speed; pinhole 2 gives the most bucket power.

Ground Engaging Tools

Teeth



Short (severe) ... for tough digging.



Long (general purpose) ... for most digging applications.



Penetration ... self-sharpening for digging in tough, compacted material.

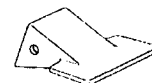

Wide (spade) ... easy digging materials, for load retention and clean-up grading.



Sharp (center)



Sharp (corner)

Sharp tip ... for maximum penetration. Recommended when penetration is more important than wear life and strength.

The Competitive Edge

Performance

- Turbocharged Cat 3116 Diesel Engine with 101 kW/ 135 FHP... excellent fuel efficiency.
- Load-sensing hydraulic system automatically adjusts the flow rate to the load encountered -- low resistance, high flow rate for fast cycle times; high resistance, low flow rate at high pressure for maximum breakout force.
- Simultaneous proportioned operation of all functions, including travel, for faster work cycles.
- Pump flow reduces to a minimum when the joysticks and travel controls are in neutral ... cutting fuel consumption.
- Pump flow increases in direct proportion to lever movement to give the operator precise control.
- High-pressure cut-off decreases the pump flow to a minimum just before the system reaches relief pressure ... conserving fuel and reducing heat build-up in the hydraulic system.
- Hydrostatic, four-wheel drive with on-the-go shifting -- forward or reverse.
- Two forward and reverse speed ranges -- work and travel.
- Overspeed valve to limit downhill speeds.
- Downshift inhibitor to prevent the machine from downshifting at excessive speeds.
- Four-wheel, oil-disc service brakes are hydraulically actuated.
- Oscillating front axle helps keep all four wheels on the ground for maximum traction and stability during travel. Operator can lock the axle from the cab for digging.
- Excellent ground clearance -- 340 mm/ 13.4"
- Lifting stability is superior to track-type machines when front and rear outriggers are used.
- A wide range of work tool -- buckets, grapples hammers and more ... extend the job opportunities.

Operating Ease/ Comfort

- Pilot-operated joysticks for short-throw, fingertip operation and precise control.
- Single lever sets oscillating axle lock, parking brake and four-wheel brakes simultaneously, or axle and brakes separately.
- Pedal-operated swing brake with lock detent ... also applies automatically after engine stops.
- Blue light in the center of the steering wheel reminds the operator that the upperstructure is within 60° of center over the fixed rear axle.
- Roomy 920 mm/ 36.22" wide cab with pressurized and filtered air circulation.
- Exceptionally low sound levels.

Reliable/ Durable

- Conservative engine rating, high displacement-to-power ratio and low operating RPM for long, reliable operation.
- O-ring face seals and SAE four-bolt flanges used on hydraulic line connections for a dry machine.
- Load-sensing hydraulics and high-pressure cut-off for reduced hydraulic pump wear and easier cold weather starting.
- Cylinder snubbers for long cylinder life.
- Transmission and drive motor located above rear axle for greater clearance and better protection.
- Steering cylinder integrated in front axle for better protection from contact and debris damage.
- Monitoring system checks critical temperatures and pressures to alert operator of potential problems.

Maintenance/ Repair

- Transmission housing, oil-disc wheel brakes, swing brake system and axle oscillation system have no specific maintenance requirements.
- Wide service doors for excellent access.
- Engine service points quickly accessible through hood opening on top of machine.
- Large battery compartment easily accommodates Caterpillar batteries.
- Quick-connect pressure taps for fast, accurate troubleshooting and adjustment of hydraulic system.

Total Customer Support

- Parts availability — most Cat parts on dealer's shelf when you need them — computer-controlled, emergency search system backup.
- Service capability — dealer's shop or fast field service — trained servicemen — latest tools and technology.
- Machine management services — effective preventive maintenance programs, diagnostic programs (Scheduled Oil Sampling, Technical Analysis), cost-effective repair options, customer meetings, operator and mechanic training.
- Exchange components for quick repairs — choose remanufactured products or rebuilt components for maximum availability and lower costs.
- Literature support -- easy-to-use operation and maintenance guides help you get the maximum value out of your equipment investment.

CATERPILLAR®