

Basic Data Menzi Muck A91

John Deere 4-cylinder engine	kW / HP	104 / 140
governed to	kW / HP	99 / 133
	rpm	2000
Displacement	ccm / cm/inch	4500 / 275
Electrical system	V	24
Battery capacity	Ah	2 x 95
Starter	kW / HP	7.2 / 9.7
Maintenance intervals	h	500
Applicable diesel fuel tank capacity	litre	330 (130/200)
(Operating tank / Reserve tank)	US-gall.	87.1 (34.3 / 52,8)
Hydraulic system capacity	litre / US-gall.	200 / 52,8
Swivelling speed max.	rpm	10
Swivel force	Nm. / lbf	46000 / 33928
Operation across slope	%	70
Operation along slope	%	100
Climbing ability on road up to	%	50
Ripping force T1,8	N / lbf	69784 / 15688
Ripping force T2	N / lbf	76762 / 17256
Breakout force	N / lbf	73600 / 16546
Lifting force max. (Dipper and Telescop cylinder)	kg / lb	6000 / 13227

Version: Menzi Muck A91 Mobile

Weight without accessories	kg / lb	9800 / 21605
Standard Speed (single stage drive)	km/h / mph	up to max. 8 / 5
Optional Speed (dual stage drive)	km/h / mph	up to max. 15 / 9,4
Standard tyre hub drive 550/60-22.5, 16 pr, Nylon	mm / inch	1240 x 550 / 4'1" x 1'10"
Optional tyre hub drive 18R/22.5 XF	mm / inch	1170 x 450 / 3'10" x 1'6"
Optional forestry tyre hub drive 600/55-26.5, 16 pr, Steel insertions	mm / inch	1350 x 600 / 4'5" x 2'
Optional forestry tyre hub drive 600/50-22.5, 16 pr, Steel insertions	mm / inch	1100 x 600 / 3'7" x 2'
Standard front tyre 300-15	mm / inch	800 x 300 / 2'7" x 1'
Optional front tyre 400/55-17.5	mm / inch	880 x 400 / 2'11" x 1'4"

Version: Menzi Muck A91 4x4

Weight without accessories	kg / lb	10000 / 22046
Speed (dual stage drive)	km/h / mph	up to max. 10 / 6,25
Standard forestry tyre hub drive 600/55-26.5, 16 pr, Steel insertions	mm / inch	1350 x 600 / 4'5" x 2'
Standard front tyre 400/55-17.5, 16 pr	mm / inch	880 x 400 / 2'11" x 1'4"

Version: Menzi Muck A91 4x4 plus

Weight without accessories	kg / lb	10500 / 23149
Speed (dual stage drive)	km/h / mph	up to max. 10 / 6,25
Standard forestry tyre 600/50-22.5, 16 pr, Steel insertions	mm / inch	1100 x 600 / 3'7" x 2'
Optional forestry tyre 600/55-26.5, 16 pr, Steel insertions	mm / inch	1350 x 600 / 4'5" x 2'
Optional tyre 550/80-23	mm / inch	1350 x 600 / 4'5" x 2'

Menzi Muck AG
Maschinenfabrik
CH-9443 Widnau
info@menzimuck.com
www.menzimuck.com

Verwaltung:
Tel. +41 071 7271212
Fax +41 071 7271213

Service:
Tel. +41 071 7271200
Fax +41 071 7271201

Technische Änderungen vorbehalten.
mba91-0207.pmd

Engine

John Deere 4-cylinder diesel engine, type 4045HF285, exhaust emission stage 3a in accordance with standard 97/68, Displacement 4500 ccm, Max. output 104 kW (140 hp), governed to 2000 rpm = 99 kW (133 hp) in accordance with SAE J1995/ISO3046. Turbo-charged with charge air cooling. Direct injection using common rail technology. Engine control unit (ECU) compensates engine pressure. Engine vibration-free on hydraulic bearings.

Hydraulic system

Latest LIFD load sensing hydraulic components (load-independent flow division) with electronic load limit sensing control. Mechanical pump power transfer gear has two performance-regulated tilting plate axial piston pumps as standard equipment: one for working hydraulics (P1) and one for the driving hydraulics (P2).

„Powerline“

An independent performance-regulated tilting plate axial piston pump (P4) with prioritised power supply can also be fitted as an option (single action for operating powerful attachments); three volume settings can be programmed. A gear pump (P3) powers the fan drive.

P1:	220 l/min. / 58 US/gall. (max. 280 bar)
P2:	160 l/min. / 42 US/gall. (max. 400 bar)
P3:	36 l/min. / 9,5 US/gall.
P4:	170 l/min. / 45 US/gall. (max. 350 bar)

Hydraulic connections

Control circuit 1

via foot pedal (proportional - double action) up to 160 l/min. / 42 US/gall.

Control circuit 2

via foot joystick (digital - double action) up to 80 l/min. / 21 US/gall.

Control circuit 3 (optional)

via foot joystick (digital - double action) up to 40 l/min. / 10.5 US/gall.

Control circuit 4 (optional)

for hydr. quick-change system (digital - double action)

„Powerline“ (optional)

via joystick (digital - single action) = three volume settings individually programmable up to 170 l/min. / 45 US/gall.

Winch connection (optional)

via foot pedal (proportional - double action) = 100 l/min. / 26 US/gall.

Load limit sensing control

Electronic power control system for faster, more sensitive and more constant interaction between engine and hydraulics. „Smooth mode“ operating mode for finer and slower movement with unlimited power. Car-style driving for comfort on public roads. Road speed set using potentiometer.

Drive

Closed circle with separate performance-regulated axial piston pump (160 l/min. / 42 US/gall.). Drive by hydrostatic wheel-hub drives with hydr. differential lock and automatic parking brake.

„H-drive system“

Increased efficiency from driving system thanks to intelligent controller with power distribution; additional stronger drive mechanism with 15 % more pulling force (model 4x4 plus).

Drive/chassis variants

Menzi Muck A91 Mobile

Single-stage two-wheel drive, speed 0-8 km/h / 0-5 mph. Optional dual-stage fast version up to 15 km/h / 9,3 mph. Telescoping support feet.

Menzi Muck A91 4x4

Dual-stage all wheel drive. Small wheels with 4 x track settings from 2360 mm to 3660 mm. Speed in first stage 0-4 km/h / 0.2,5 mph; second stage up to max. 10 km/h / 6,2 mph. Telescoping support feet. Hydraulic lifting axle for small wheels (optional).

Menzi Muck A91 4x4 plus

Dual-stage all-wheel drive with four large wheels. Front wheels with double-pivot steering. „H-drive system“. Minimal turning circle diameter: 12.5 m. Speed first drive position 0 – 4 km/h / 0.2,5 mph, second position up to 10 km/h / 6,2 mph. Hydr. brace (optional). Speeds vary depending on tyres fitted.

Model changes and innovations coming soon

Apply to all models:

- Engine output: + 6 kW (8 hp)
- John Deere engine with common rail (exhaust emission stage 3a)
- New chassis control with quicker support functions, independently and simultaneously operable
- Mechanical pump distribution gear with speed ratios
- Drive pump: delivery rate: 160 l/min. / 42 US/gall. (+ 25 l/min. / 6,6 US/gall.)
- Car-like driving
- Electronic load limit sensing control
- Increased battery capacity (+ 40 Ah)
- Newly designed and larger cooling system
- High-quality forestry tyres as standard on 4x4 and 4x4 plus
- Option: „Powerline“ = independent pump with prioritised supply for hydr. attachments up to 170 l/min. / 45 US/gall. Constant output for powerful attachments, with three volume settings programmable via display.

New for 4x4 plus model variant:

- H-drive system: increased efficiency of drive thanks to intelligent controller + approx. 15 % more powerful drive
- New double-pivot steering with increased steering angle
- High-quality forestry tyres as standard

Electrical system

24 volt, 95 Ah battery, 45 amp alternator, 7.2 kW starter. Electric output 1080 watt. Option: 100 amp alternator

Chassis control

Fast, parallel and independent chassis functions using CAN BUS system. IP69 components guarantee continuous operation in water.

Safety cab/driving area

Comfortable and spacious cab with all-round view and sprung seat, low-vibration on rubber mounts, roll prevention, ROPS test according to DIN ISO 3471; Optional FOPS roof. The cab can be hydraulically tilted. Large, clear LCD display, ergonomically designed with display of numerous indicators, such as engine rpm, operating hours counter and clock, fuel gauge, temperature, battery level, filter check, service indicators, control and diagnostic functions, etc.

Controls

Two ergonomic multi-joysticks, each with max. 25 functions. Logical design for ease of use of chassis and bucket functions. Foot pedals for actuation of boom, drive, hydraulic attachment and winch. Height and angle of joysticks and foot pedals can be adjusted to suit the operator.

Optional equipment

Equipment for the hoist attachment; hydraulic telescoping feet/slope supports; biodegradable hydraulic fluid; air conditioning system; central lubrication system; „Powerline“; customer choice of paint colour; street equipment; fast version; hydraulic freewheeling switch; winch connection to chassis/arm; third, double-action control circuit; control circuit for hydr. quick-change system; special tyres; leak oil tube; bypass filter (fine filter); soot particle filter; manual lubrication system for boom; 1800 mm boom; forestry cab with Lexan windows; spotlights on roof and customer-specific requirements.

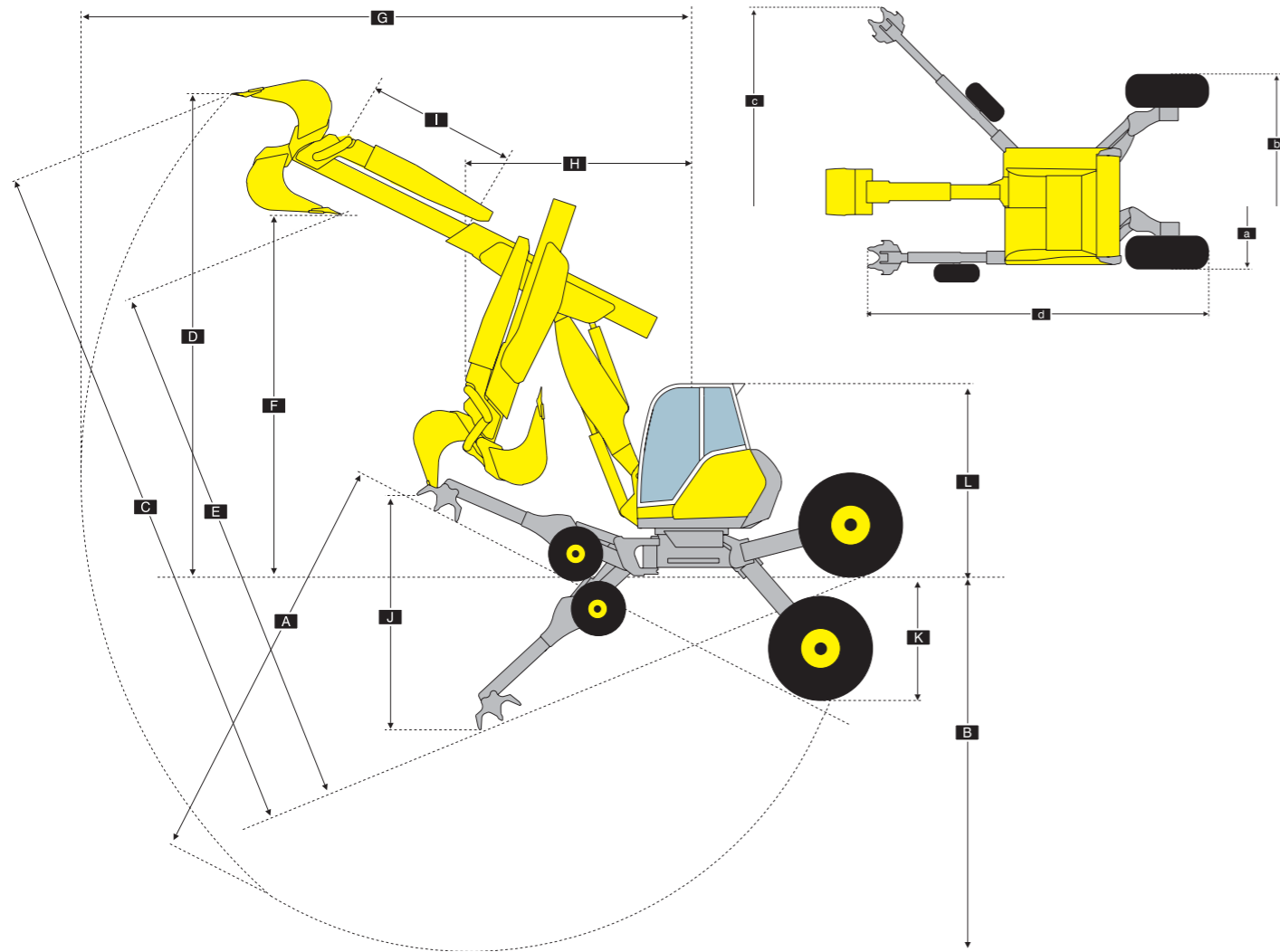

Measurements Menzi Muck A91 Mobil / A91 4x4

		T2	T1.8
A	Max. Excavation depth (with adjusted chassis)	inch/mm	19'6" / 5960 20'4" / 6210
B	Max. Excavation depth (chassis horizontally)	inch/mm	17'9" / 5430 18'7" / 5670
C	Max. Excavation height (with adjusted chassis)	inch/mm	31'2" / 9510 31'8" / 9650
D	Max. Excavation height (chassis horizontally)	inch/mm	22'6" / 6870 22'8" / 6910
E	Max. Discharge height (with adjusted chassis)	inch/mm	23' / 7030 23'5" / 7160
F	Max. Discharge height (chassis horizontally)	inch/mm	15'10" / 4830 15'11" / 4860
G	Max. Jib Range	inch/mm	28'1" / 8570 28'10" / 8790
H	Smallest svivelling radius	inch/mm	9'10" / 3000 9'9" / 2980
I	Dipper length	inch/mm	6'5" / 1960 5'10" / 1800
J	Positioning range stabilizers	inch/mm	10'2" / 3110 do. T1,8
K	Positioning range hub drive	inch/mm	5'4" / 1640 do. T1,8
L	Transport height	inch/mm	8'5" / 2570 do. T1,8
a	Minimum width hub drive (transport width)	inch/mm	6'9" / 2080 do. T1,8
b	Max. positioning width hub drive	inch/mm	14'5" / 4400 do. T1,8
c	Max. positioning width stabilizers	inch/mm	21'7" / 6590 do. T1,8
d	Chassis length	inch/mm	18'6" / 5660 do. T1,8

Measurements depend on type of tyre and accessories.

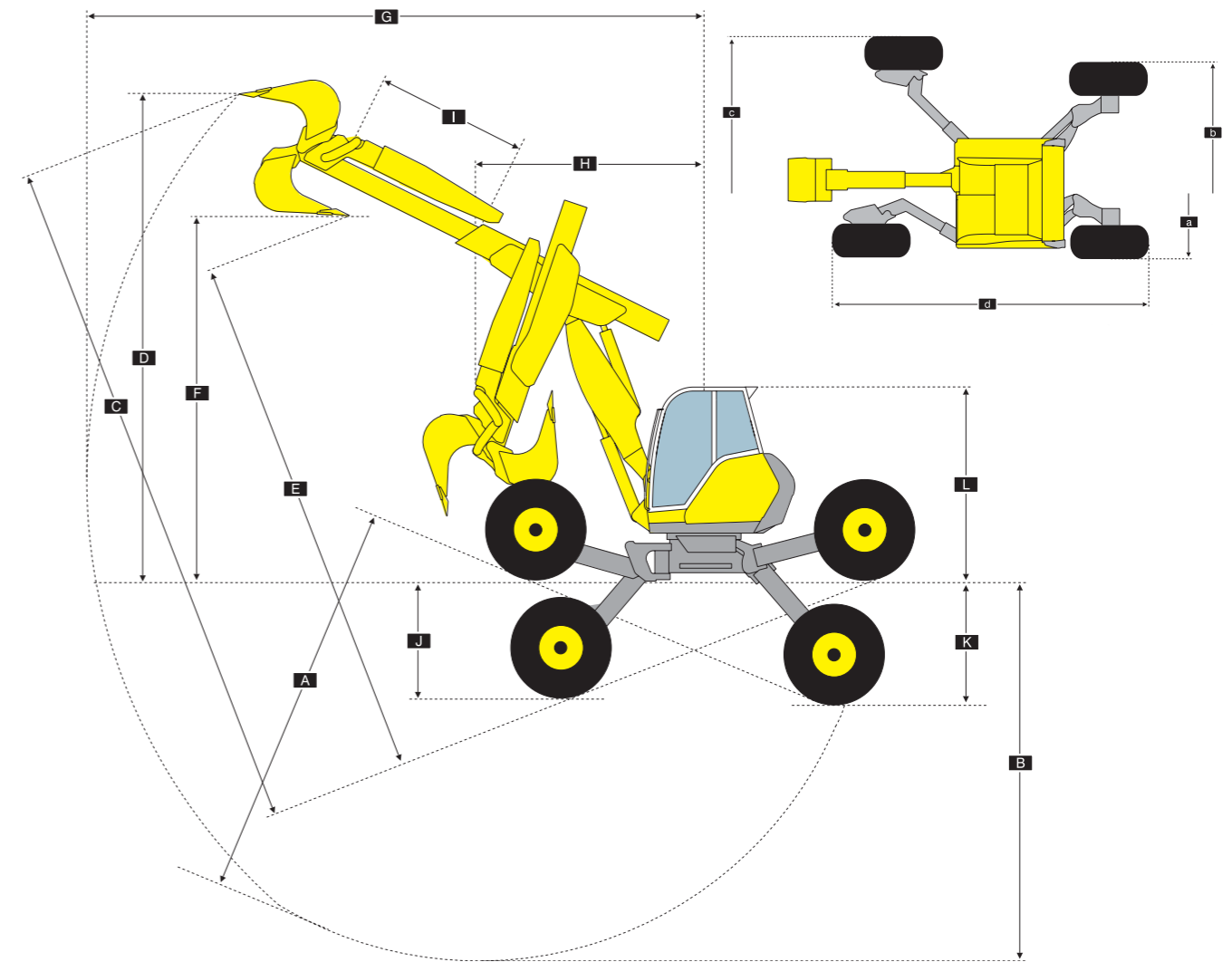

Measurements Menzi Muck A91 4x4 plus

		T2	T1.8
A	Max. Excavation depth (with chassis adjustment)	inch/mm	18'8" / 5680 19'5" / 5920
B	Max. Excavation depth (chassis horizontally)	inch/mm	17'9" / 5420 18'7" / 5670
C	Max. Excavation height (with chassis adjustment)	inch/mm	30'11" / 9420 31'4" / 9550
D	Max. Excavation height (chassis horizontally)	inch/mm	22'6" / 6870 22'8" / 6910
E	Max. Discharge height (with chassis adjustment)	inch/mm	22'9" / 6950 23'2" / 7070
F	Max. Discharge height (chassis horizontally)	inch/mm	15'10" / 4830 15'11" / 4860
G	Max. Jib Range	inch/mm	28'1" / 8570 28'10" / 8790
H	Smallest svivelling radius	inch/mm	9'10" / 3000 9'9" / 2980
I	Dipper length	inch/mm	6'5" / 1960 5'10" / 1800
J	Positioning range stabilizers	inch/mm	5'1" / 1550 dto. T1,8
K	Positioning range hub drive	inch/mm	5'4" / 1640 dto. T1,8
L	Transport height	inch/mm	8'5" / 2570 dto. T1,8
a	Minimum width hub drive (transport width)	inch/mm	7'7" / 2330 dto. T1,8
b	Max. positioning width hub drive	inch/mm	15'2" / 4630 dto. T1,8
c	Max. positioning width stabilizers	inch/mm	18'2" / 5530 dto. T1,8
d	Chassis length	inch/mm	18'7" / 5710 dto. T1,8

Measurements depend on type of tyre and accessories.