

# KOMATSU®

## PC138USLC-11

Tier 4 Final Engine

### HYDRAULIC EXCAVATOR



Photos may include optional equipment.

#### NET HORSEPOWER

97.2 HP @ 2050 rpm  
72.5 kW @ 2050 rpm

#### OPERATING WEIGHT

34,563–37,547 lb  
15,682–17,032 kg

#### BUCKET CAPACITY

0.34–1.00 yd<sup>3</sup>  
0.26–0.76 m<sup>3</sup>

# PC138USLC

# WALK-AROUND

PC138USLG-11



Photos may include optional equipment.

**NET HORSEPOWER**  
97.2 HP @ 2050 rpm  
72.5 kW @ 2050 rpm

**OPERATING WEIGHT**  
34,563–37,547 lb  
15,682–17,032 kg

**BUCKET CAPACITY**  
0.34–1.00 yd<sup>3</sup>  
0.26–0.76 m<sup>3</sup>



## CONVENTIONAL PERFORMANCE IN A TIGHT TAIL BODY

Heavy counterweight mass provides equal or better lift capacity than most conventional excavators in the same size class.

Rounded cab profile with a sliding door, allows the cab to swing within the same swing radius as the counterweight for true tight tail performance.



A powerful Komatsu SAA4D95LE-7 engine provides a net output of 72.5 kW **97.2 HP**. This engine is EPA Tier 4 Final emissions certified.

**Variable Flow Turbocharger** improves engine response and provides optimum air flow under all speed and load conditions.

**Komatsu Diesel Oxidation Catalyst (KDOC)** reduces particulate matter using passive regeneration **100% of the time**. No active or manual regeneration is required.

**Selective Catalytic Reduction (SCR)** reduces NOx and has easy to access components.

**Komatsu Auto Idle Shutdown** helps reduce nonproductive engine idle time and reduces operating costs.

**Komatsu's Closed-center Load Sensing System (CLSS)** provides quick response and smooth operation to maximize productivity.

**Enhanced working modes** are designed to match engine speed, pump delivery, and system pressure to the application.

**Temperature controlled fan clutch** helps improve fuel efficiency and lower sound levels.

### Large LCD color monitor panel:

- 7" high resolution screen
- Provides "Ecology-Guidance" for fuel efficient operation
- Enhanced attachment control

### Aux jack and (2) 12V outlets

### Rearview monitoring system (standard)

**Equipment Management Monitoring System (EMMS)** continuously monitors machine operation and vital systems to identify machine issues and assist with troubleshooting.

### Enhanced working environment

- Integrated ROPS cab design (ISO 12117-2)
- Cab meets ISO Level 1 Operator Protective Guard (OPG) top guard (ISO 10262)

**Wide access service doors** provide easy access for ground level maintenance.

### Komatsu designed and manufactured components

**New engine and hydraulic control technology** improves operational efficiency and lowers fuel consumption by up to 4%.

**New quick return arm valve** improves arm cylinder hydraulic flow for faster arm out speed and performance.

**Handrails (standard)** provides convenient access to the upper structure.

**Battery disconnect switch** allows a technician to disconnect the power supply before servicing the machine.

The **KOMTRAX®** telematics system is standard on Komatsu equipment with no subscription-fee's throughout the life of the machine. Using the latest wireless technology, **KOMTRAX®** transmits valuable information such as location, utilization, and maintenance records to a PC or smart-phone app. Custom machine reports are provided for identifying machine efficiency and operating trends. **KOMTRAX®** also provides advanced machine troubleshooting capabilities by continuously monitoring machine health.

# PERFORMANCE FEATURES

## KOMATSU NEW ENGINE TECHNOLOGIES

### New Tier 4 Final Engine

New regulations require the reduction of NOx emissions to one tenth or below from the preceding regulations. Komatsu has developed a new Selective Catalytic Reduction (SCR) device for use in the PC138USLC-11 and other models.

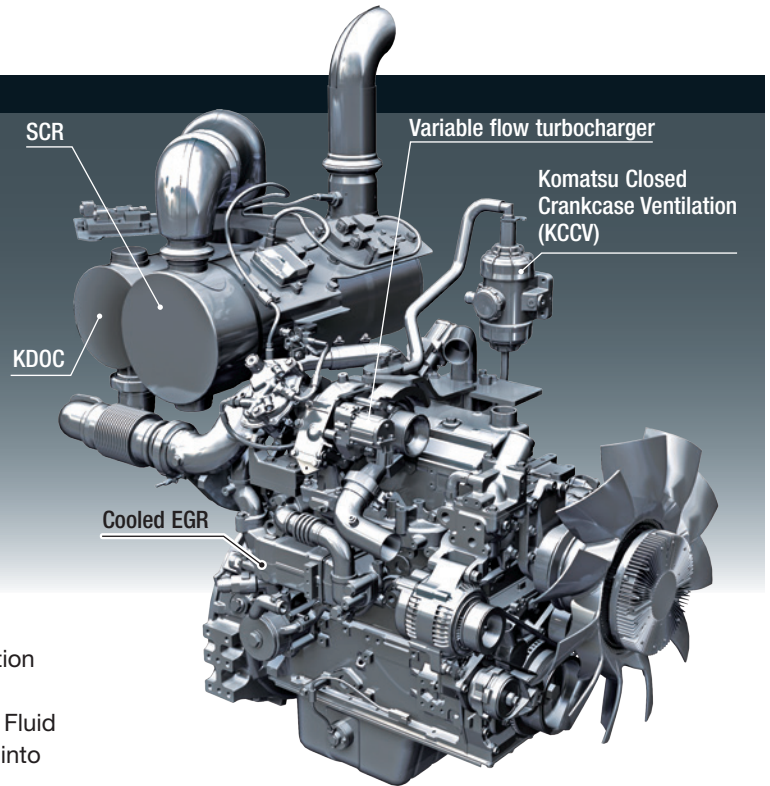

### Technologies Applied to New Engine

#### Heavy-duty aftertreatment system

This new system combines a Komatsu Diesel Oxidation Catalyst (KDOC) and SCR. The SCR NOx reduction system injects the correct amount of Diesel Exhaust Fluid (DEF) at the proper rate, thereby decomposing NOx into non-toxic water (H<sub>2</sub>O) and nitrogen gas (N<sub>2</sub>).

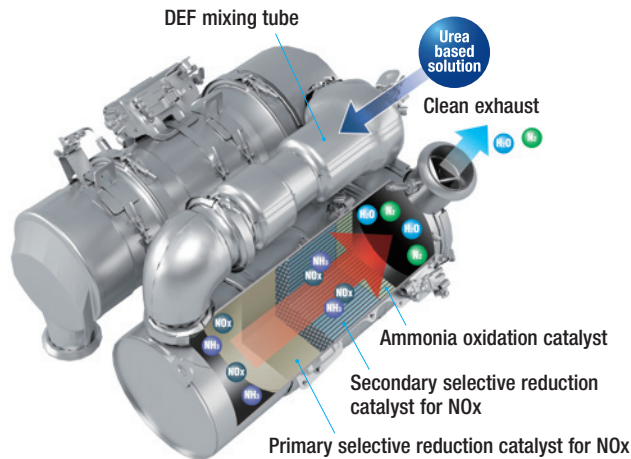

#### Variable flow turbocharger

A variable flow turbocharger features simple and reliable technology that varies the intake air-flow. The Exhaust turbine speed is controlled by a flow control valve that optimizes air volume to the engine combustion chamber under all engine speed and load conditions. The result is cleaner exhaust gas while maintaining power and performance.

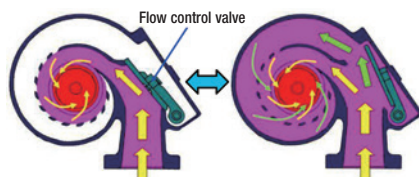

#### Heavy-duty cooled Exhaust Gas Recirculation (EGR) system

The system recirculates a portion of exhaust gas into air intake and lowers combustion temperatures to reduce NOx emissions. Furthermore, while EGR gas flow is increased, by incorporating a high-efficiency and compactly designed cooling system, the system achieves a dynamic reduction of NOx, while helping reduce fuel consumption.

#### Advanced Electronic control system

The electronic control system performs high-speed processing of all signals from sensors installed in the machine providing total control of equipment in all operating conditions of use. Engine condition information is displayed via an onboard network to the monitor inside the cab, providing necessary information to the operator. Additionally, managing the information via KOMTRAX helps customers keep up with required maintenance.

#### High Pressure Common Rail (HPCR) fuel injection system

High pressure fuel injection with computerized control attains close to complete combustion reducing Particulate Matter (PM) emissions. While this technology is already used in current engines, the new system uses a higher-pressure injection, thereby reducing both PM emissions and fuel consumption at all engine load conditions.

PC138USLC-11

## Fuel consumption is reduced up to 4%

Fuel consumption is reduced up to 4% using a temperature controlled viscous fan clutch and improved engine and hydraulic system efficiencies.

### Fuel Consumption

Compared to the PC138USLC-10

## Reduced by up to 4%

Based on typical work pattern collected via KOMTRAX. The fuel consumption reduction may be less than the above value during actual work, depending on the application. The fuel consumption data is based on in-house test results.

### Komatsu Auto Idle Shutdown

Komatsu auto idle shutdown automatically shuts the engine down after idling for a set period of time to reduce unnecessary fuel consumption and exhaust emissions. The countdown to engine shutdown can be easily programmed from 5 to 60 minutes.

### Efficient hydraulic system

The PC138USLC-11 uses a Closed-center Load Sensing System (CLSS) that improves fuel efficiency and provides quick response to the operator's demands. The control system matches engine and hydraulic demand at the most efficient point under any load condition. There have also been improvements in the main valve and hydraulic circuit to reduce hydraulic loss, resulting in higher efficiency and lower fuel consumption.

### Viscous fan clutch

Reduces engine loads at lower operating temperatures.

## Working Mode Selection

The PC138USLC-11 excavator is equipped with six working modes (P, E, L, B, ATT/P and ATT/E). Each mode is designed to match engine speed, pump flow, and system pressure to the application. The PC138USLC-11 features an attachment mode (ATT/E) that allows operators to run attachments while in Economy mode.

Working Mode	Application	Advantage
P	Power mode	<ul style="list-style-type: none"> <li>•Maximum production/power</li> <li>•Fast cycle times</li> </ul>
E	Economy mode	<ul style="list-style-type: none"> <li>•Good cycle times</li> <li>•Better fuel economy</li> </ul>
L	Lifting mode	<ul style="list-style-type: none"> <li>•Increases hydraulic pressure</li> </ul>
B	Breaker mode	<ul style="list-style-type: none"> <li>•Optimum engine rpm, hydraulic flow</li> </ul>
ATT/P	Attachment Power mode	<ul style="list-style-type: none"> <li>•Optimum engine rpm, hydraulic flow, 2-way</li> <li>•Power mode</li> </ul>
ATT/E	Attachment Economy mode	<ul style="list-style-type: none"> <li>•Optimum engine rpm, hydraulic flow, 2-way</li> <li>•Economy mode</li> </ul>

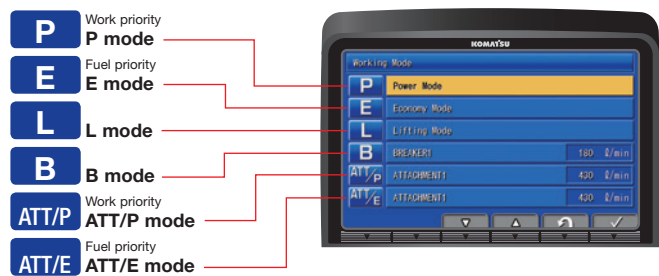

### Arm quick return valve

When the arm is extended, the quick return valve directs additional oil through a second line directly back to tank which reduces back pressure. Reduces fuel consumption and improves efficiency.



# PERFORMANCE FEATURES

PC138USLC-11



## Blade Ready

Every PC138USLC-11 is equipped for easy field installation of a wide 2590 mm 8'6" blade.



## High Breakout Forces

The PC138USLC-11 provides high breakout forces for operation in difficult digging conditions.

## Fine Controllability

Proportional Pilot Controls (PPC) allow the operator finite control and feed back with minimal effort for comfort and efficiency.

## High Mobility

The PC138USLC-11 is equipped with two speed travel and automatic shift with a high drawbar pull for work in wet or muddy conditions and blade applications.

## Pattern Change Valve (Standard)

A pattern change valve is conveniently located at the front of the machine, making switching from excavator controls to backhoe controls quick and easy.

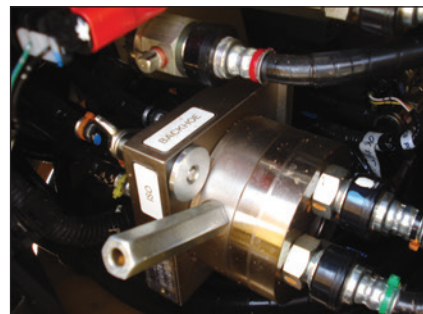

# OPERATION FEATURES

## SHORT SWING RADIUS

### Short Implement Swing Radius

A higher boom raise angle than a standard excavator reduces the minimum front implement swing radius down to 1980mm 6'6". The result is greater front swing clearance when space is limited.

### Short Tail Swing Radius

1545 mm 5'1" short tail swing radius of the PC138USLC-11 allows the machine to work in more confined areas than a conventional machine.

### Ideal for Confined Applications

The PC138USLC-11 is an ideal machine for applications such as road work, underground utilities or other applications where a conventional excavator will not fit. The contoured cab design and convex sliding door allow the cab to swing within the same radius as the counterweight. Trucks can be positioned closer to the machine when working within one lane of traffic, improving operator confidence and job efficiency.



**301 mm**  
**12"**

Edge of track to outside of cab mirror

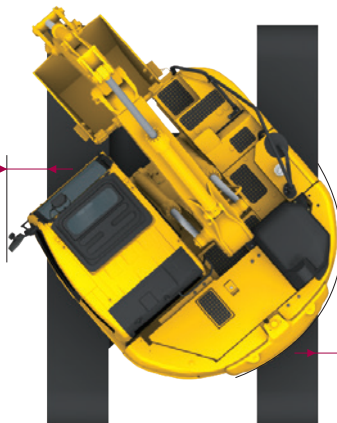

**250 mm**  
**10"**

Edge of track to outside of counterweight

**250 mm**  
**10"**

Edge of track to outside of counterweight

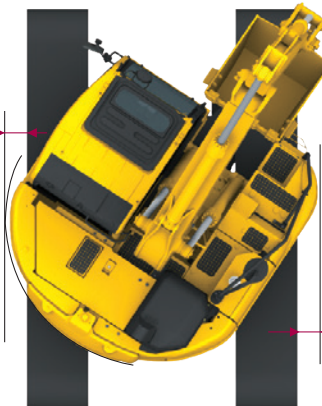

**185 mm**  
**7.5"**

Edge of track to handrail

Shoe width is 600 mm 24".

# OPERATION FEATURES

## ROPS CAB STRUCTURE

### ROPS Cab (ISO 12117-2)

The machine is equipped with a ROPS cab that conforms to ISO 12117-2 for excavators as standard equipment. It also satisfies the requirements for Level 1 Operator Protective Guard (OPG) and top guard (ISO 10262).



## Rear View Monitoring System

An updated rear view monitoring system display has a camera image that is continuously displayed together with the gauges and important vehicle information. This enables the operator to carry out work while easily checking the surrounding area.



## Low Vibration with Viscous Cab Mounts

The PC138USLC-11 uses viscous mounts for the cab that incorporate a longer stroke and the addition of a spring. The cab damper mounting combined with a high rigidity deck reduces vibration at the operator's seat.

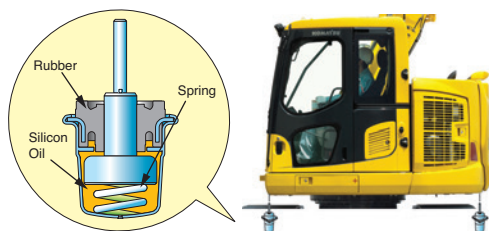

## General Features

- Lock lever
- Seat belt, retractable
- Tempered & tinted glass
- Large mirrors
- Slip-resistant plates
- Thermal and fan guards
- Pump/engine room partition
- Travel alarm
- Large cab entrance step
- Handrails
- Sliding door

**Secondary engine shut down switch** at base of seat to shutdown the engine.





# WORKING ENVIRONMENT

## Comfortable Working Space

### Large cab with wide front view and foot space

A large operator cab with rounded corner provides an overall cab size similar to a standard excavator cab even though this machine has an extra small swing radius. A sliding door enables easy access especially in confined work areas. Additional operator comfort is provided with a fully adjustable suspension seat.



### Automatic Air Conditioner

The automatic air conditioner allows the operator to easily and precisely set the cab atmosphere using the large LCD color monitor panel. The bi-level control function improves air flow and keeps the inside of the cab comfortable throughout the year.



### Auxiliary input jack

Connecting an auxiliary device such as an MP3 player to the auxiliary input enables the operator to hear the sound throughout the stereo speakers installed in the cab.



### Low cab noise

## Standard Equipment

Automatic air conditioner (A/C)

Pull-up front window

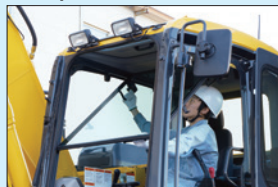

Remote intermittent wiper with windshield washer



Cab light

Opening & closing skylight



Defroster (conforms to the ISO standard)



Windshield glass with excellent UV filtering

AM/FM radio



Cup holder



Literature box



Cigarette lighter & 12 V power supply



# WORKING ENVIRONMENT

PG138USLG-11

## LARGE HIGH RESOLUTION LIQUID CRYSTAL DISPLAY (LCD) MONITOR



### New Monitor Panel Interface Design

An updated large high resolution LCD color monitor enables accurate and smooth work. The interface has been redesigned to display key machine information in a new user friendly interface. A rear view camera and a DEF level gauge display have been added to the default main screen. The interface has a function that enables the main screen mode to be changed to provide the optimum screen information for the operator.

#### Indicators

- |                                    |                             |
|------------------------------------|-----------------------------|
| 1 Auto-decelerator                 | 8 Fuel gauge                |
| 2 Working mode                     | 9 DEF level gauge           |
| 3 Travel speed                     | 10 Service meter, clock     |
| 4 Ecology gauge                    | 11 Fuel consumption gauge   |
| 5 Camera display                   | 12 Guidance icon            |
| 6 Engine coolant temperature gauge | 13 Function switches        |
| 7 Hydraulic oil temperature gauge  | 14 Camera direction display |
|                                    | 15 DEF level caution lamp   |

#### Basic operation switches

- |                         |                         |
|-------------------------|-------------------------|
| 1 Auto-decelerator      | 4 Buzzer cancel         |
| 2 Working mode selector | 5 Wiper                 |
| 3 Travel speed selector | 6 Window washer         |
|                         | 7 Auto climate controls |

### Switchable display modes

The updated monitor screen display mode can be easily switched by pressing the F3 key.

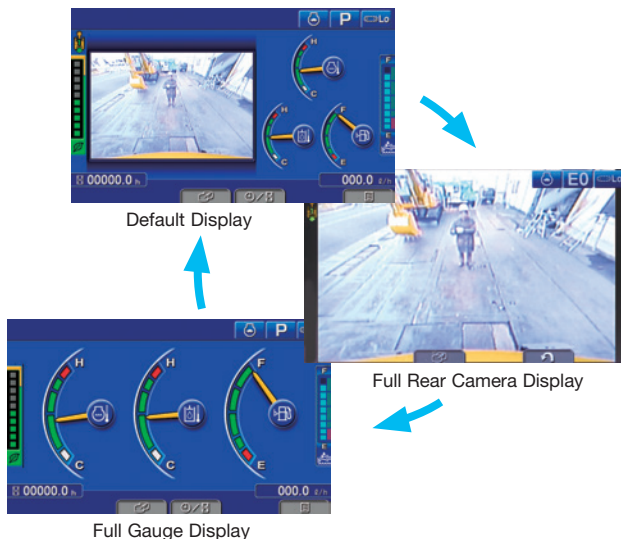

### Visual user menu

Pressing the F6 key on the main screen displays the user menu screen. The menus are grouped for each function, and use easy-to-understand icons which enable the machine to be operated easily.



- 1 Energy saving guidance
- 2 Machine settings
- 3 Aftertreatment device regeneration\*
- 4 SCR information
- 5 Maintenance
- 6 Monitor setting
- 7 Message check

\*Blank screen, does not apply to SAA4D95LE-7. The DOC is 100% passive regeneration.

### Operator Identification Function

An operator identification (ID) code can be set for each operator and used to manage operation information of individual machines using KOMTRAX data. Data sent from KOMTRAX can be used to analyze operation status by operator, application etc. as well as by machine.



### Support Efficiency Improvement

#### Ecology guidance

While the machine is operating, Ecology guidance information can be displayed on the monitor screen to provide fuel saving advice in real time.

#### Ecology gauge & fuel consumption gauge

The monitor screen includes an Ecology gauge and a fuel consumption gauge which is displayed continuously. The operator can set a target value.



Ecology gauge      Fuel consumption gauge  
Ecology guidance

### Operation records, fuel consumption history, and Ecology guidance records

The Ecology guidance menu enables the operator to check the operation records, fuel consumption history and Ecology guidance records.

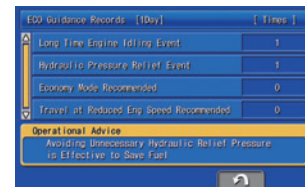

Ecology guidance record



Operation record



Fuel consumption history



# MAINTENANCE FEATURES

## Standard high-efficiency fuel filter and fuel pre-filter with water separator

A high-efficiency fuel filter and a fuel pre-filter with water separator increase reliability. The fuel pre-filter is equipped with a priming pump.

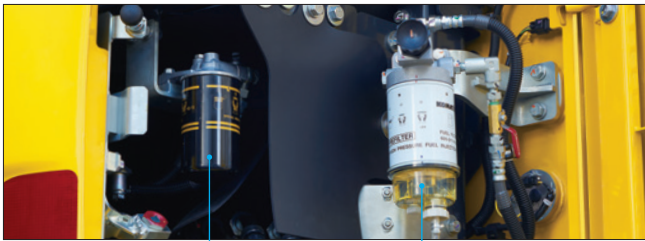

High efficiency fuel filter

Fuel pre-filter (With water separator)

## Easy access to engine oil filter, engine main fuel filter and fuel drain valve

The engine oil filter, engine main fuel filter and fuel drain valve are remote mounted to improve accessibility.



Engine oil filter



Fuel drain valve

## Battery disconnect switch

A standard battery disconnect switch allows a technician to disconnect the power supply and lock out before servicing the machine.

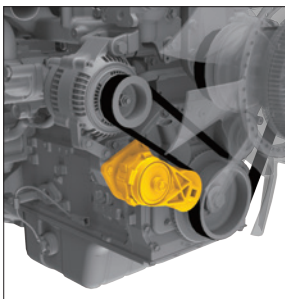

## Fan belt auto-tensioner

For maintenance free fan belt tension adjustment.

## Long-life oil, filter

Engine oil & engine oil filter every **500** hours

Hydraulic oil every **5000** hours

Hydraulic oil filter every **1000** hours



Hydraulic oil filter (Ecology white plus element)

## Attachment circuit filter

An easy access filter protects the hydraulic system from attachment contaminants (included with factory + 1 attachment piping).

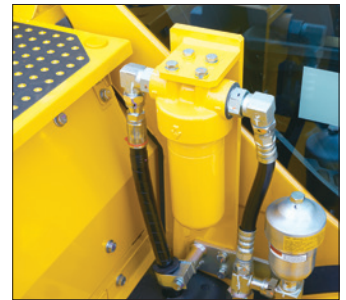

## A/C filter

The A/C, cab air filter is serviced without the use of tools.

## DEF tank and pump

Designed for ground level access, the DEF tank includes a sight glass gauge and the DEF pump and filter are conveniently located next to the DEF tank.

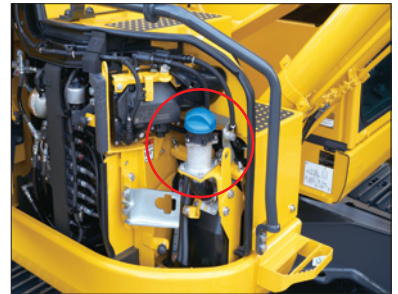

## Side-by-side cooling

The radiator and oil cooler are side-by-side modules which simplifies cleaning, removal and installation. The addition of screens help keep the cooler cores clean and free of debris.

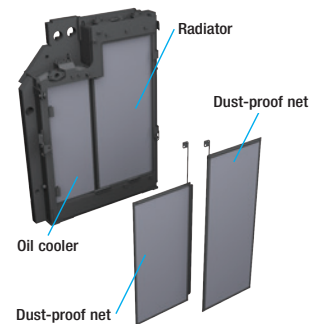

## Large tool box

A tool box large enough for storing a grease gun is provided as standard.



## Easy-to-clean cab floor mat

The PC138USLC-11's surface grooves run parallel to the operator and has a flanged edge combined with drainage holes to allow water run off when cleaning the cab.

PC138USLC-11



**Maintenance Information**

**“Maintenance time caution lamp” display**

When the remaining time to maintenance becomes less than 30 hours\* a maintenance time monitor appears.

\* The settings can be changed to between 10 and 200 hours.



Maintenance screen

**Aftertreatment device automatic regeneration display**

When performing automatic regeneration to clean any urea deposits in the exhaust system, the monitor will display an action icon to the operator.

There is no interruption to the operation of the machine during this cycle.



Aftertreatment device regeneration screen

**DEF level and refill timing**

The DEF level gauge is displayed continuously on the right side of the monitor screen. In addition, when the DEF level is low, DEF low level guidance messages appear as pop up displays to inform the operator.

\* The 2014 standards for exhaust gases stipulates that when DEF level becomes low the engine must derate.



DEF level gauge



DEF low level guidance

# KOMATSU PARTS & SERVICE SUPPORT



## KOMATSU CARE

### Program Includes:

\*The PC138USLC-11 comes standard with complimentary factory scheduled maintenance for the first 3 Years or 2,000 Hours, whichever comes first.

### Planned Maintenance Intervals at:

500/1000/1500/2000 hour intervals. (250 hr. initial interval for some products) Complimentary Maintenance Interval includes: Replacement of Oils & Fluid Filters with genuine Komatsu Parts, 50-Point inspection, Komatsu Oil & Wear Analysis Sampling (KOWA) / Travel & Mileage (distance set by distributor; additional charges may apply)

### Benefits of Using Komatsu CARE

- Assurance of Proper Maintenance with OEM Parts & Service
- Increased Uptime & Efficiency
- Factory Certified Technicians Performing Work
- Cost of Ownership Savings
- Transferable Upon Resale

### Complimentary SCR System Maintenance

The PC138USLC-11 also includes 2 factory recommended services of the Selective Catalytic Reduction (SCR) Diesel exhaust fluid (DEF) system during the first 5 years—no hour limit—including:

- Factory recommended DEF tank flush and strainer cleaning at 4,500 hours and 9,000 hours

KOMATSU CARE PCI38USLC-11				
Interval PM	500	1000	1500	2000
KOWA SAMPLING – (Engine, Hydraulics, Swing Circle, L & R Final Drives)	✓	✓	✓	✓
LUBRICATE MACHINE	✓	✓	✓	✓
LUBRICATE SWING CIRCLE	✓	✓	✓	✓
CHECK SWING PINION GREASE LEVEL AND ADD, WHEN NECESSARY	✓	✓	✓	✓
CHANGE ENGINE OIL	✓	✓	✓	✓
REPLACE ENGINE OIL FILTER	✓	✓	✓	✓
REPLACE FUEL PRE-FILTER	✓	✓	✓	✓
REPLACE AC FRESH & RECIRC AIR FILTERS	✓	✓	✓	✓
CLEAN AIR CLEANER ELEMENT	✓	✓	✓	✓
DRAIN SEDIMENT FROM FUEL TANK	✓	✓	✓	✓
COMPLETE 50 POINT INSPECTION FORM; LEAVE PINK COPY WITH CUSTOMER OR IN CAB	✓	✓	✓	✓
RESET MONITOR PANEL MAINTENANCE COUNTER FOR APPROPRIATE ITEMS	✓	✓	✓	✓
REPLACE HYDRAULIC TANK BREATHER ELEMENT		✓		✓
REPLACE DEF TANK BREATHER ELEMENT		✓		✓
CHANGE FINAL DRIVE OIL		✓		✓
CHECK OIL LEVEL IN PTO GEAR AND ADD, WHEN NECESSARY		✓		✓
REPLACE MAIN FUEL FILTER		✓		✓
REPLACE HYDRAULIC OIL FILTER ELEMENT		✓		✓
CHANGE SWING MACHINERY OIL		✓		✓
CLEAN HYDRAULIC TANK STRAINER				✓
REPLACE KCCV FILTER ELEMENT				✓
REPLACE DEF PUMP FILTER				✓
FACTORY TRAINED TECHNICIAN LABOR	✓	✓	✓	✓

\* Certain exclusions and limitations apply. Refer to the customer certificate for complete program details and eligibility. Komatsu® and Komatsu Care® are registered trademarks of Komatsu Ltd. Copyright 2017 Komatsu America Corp.

## Komatsu CARE® – Extended Coverage

- Extended Coverage can provide peace of mind by protecting customers from unplanned expenses that effect cash flow
- Purchasing extended coverage locks-in the cost of covered parts and labor for the coverage period and helps turn these into fixed costs



## Komatsu Parts Support

- 24/7/365 to fulfill your parts needs
- 9 parts Distribution Centers strategically located across the U.S. and Canada
- Distributor network of more than 300 locations across U.S. and Canada to serve you
- Online part ordering through Komatsu eParts
- Remanufactured components with same-as-new warranties at a significant cost reduction



## Komatsu Oil and Wear Analysis (KOWA)

- KOWA detects fuel dilution, coolant leaks, and measures wear metals
- Proactively maintain your equipment
- Maximize availability and performance
- Can identify potential problems before they lead to major repairs
- Reduce life cycle cost by extending component life

PC138USLC-11

# KOMTRAX EQUIPMENT MONITORING

GET THE WHOLE STORY WITH  
**KOMTRAX**<sup>®</sup>

## ✓ WHAT

- KOMTRAX is Komatsu's remote equipment monitoring and management system
- KOMTRAX **continuously monitors and records** machine health and operational data
- Information such as fuel consumption, utilization, and a detailed history **lowering owning and operating cost**

## ✓ WHO

- KOMTRAX is **standard** equipment on all Komatsu construction products

## ✓ WHEN

- Knowing when machines are **running or idling** can help improve fleet utilization
- Detailed movement records ensure you know when and where your equipment is moved
- Up to date records allow you to **know when maintenance is due** and help you plan for future maintenance needs

## ✓ WHERE

- KOMTRAX data **can be accessed virtually anywhere** through your computer, the web or your smart phone
- Automatic alerts keep fleet managers up to date on the latest machine notifications

## ✓ WHY

- Knowledge is power - **make informed decisions** to manage your fleet better
- Knowing your idle time and fuel consumption will help maximize your machine efficiency
- **Take control of your equipment** - any time, anywhere



**KOMTRAX**<sup>®</sup>

For construction and compact equipment.

**KOMTRAX Plus**<sup>®</sup>

For production and mining class machines.

# SPECIFICATIONS



## ENGINE

Model..... Komatsu SAA4D95LE-7\*  
 Type..... Water-cooled, 4-cycle, direct injection  
 Aspiration..... Variable flow, turbocharged, air-to-air aftercooled  
 Number of cylinders..... 4  
 Bore..... 95 mm **3.74"**  
 Stroke..... 115 mm **4.53"**  
 Piston displacement..... 3.26 ltr **199 in<sup>3</sup>**  
 Horsepower:  
 SAE J1995..... Gross 72.6 kW **97.3 HP**  
 ISO 9249 / SAE J1349..... Net 72.5 kW **97.2 HP**  
 Rated rpm..... 2050  
 Fan at maximum speed..... Net 67.8 kW **90.9 HP**  
 Fan drive method for radiator cooling..... Mechanical with viscous clutch

Governor..... All-speed control, electronic

\*EPA Tier 4 Final emissions certified



## HYDRAULICS

Type..... HydrauMind (Hydraulic Mechanical Intelligence) system, closed-center system with load sensing valve and pressure compensated valve

Number of selectable working modes..... 6

Main pump:

Type..... Variable capacity piston type  
 Pump for..... Boom, arm, bucket, swing, and travel circuits  
 Maximum flow..... 242 ltr/min **64 gal/min**

Hydraulic motors:

Travel..... 2 x piston motor with parking brake  
 Swing..... 1 x piston motor with swing holding brake

Relief valve setting:

Implement circuits..... 34.8 MPa 355 kgf/cm<sup>2</sup> **5,050 psi**  
 Travel circuit..... 34.8 MPa 355 kgf/cm<sup>2</sup> **5,050 psi**  
 Swing circuit..... 29.2 MPa 298 kgf/cm<sup>2</sup> **4,240 psi**  
 Pilot circuit..... 3.2 MPa 33 kgf/cm<sup>2</sup> **470 psi**

Maximum Auxiliary Flow..... 242 ltr/min **64 gal/min**  
 at 250 kgf/cm<sup>2</sup> **3,553 psi\***

Hydraulic cylinders:

(Number of cylinders – bore x stroke x rod diameter)

Boom 2–105 mm x 1055 mm x 70 mm **4.1" x 41.5" x 2.76"**  
 Arm .... 1–110 mm x 1175 mm x 75 mm **4.3" x 46.3" x 2.95"**  
 Bucket.. 1–95 mm x 885 mm x 65 mm **3.7" x 34.8" x 2.56"**



## DRIVES AND BRAKES

Steering control..... Two levers with pedals

Drive method..... Fully hydrostatic

Maximum drawbar pull..... 123 kN 12500 kgf **27,560 lbf**

Gradeability..... 70%, 35°

Maximum travel speed: High..... 5.1 km/h **3.2 mph**  
 (Auto-shift) Low..... 2.9 km/h **1.8 mph**

Service brake..... Hydraulic lock

Parking brake..... Wet, multiple-disc



## SWING SYSTEM

Driven by..... Hydraulic motor  
 Swing reduction..... Planetary gear  
 Swing circle lubrication..... Grease-bathed  
 Service brake..... Hydraulic lock  
 Swing lock..... Wet, multiple-disc brake  
 Swing speed..... 11.0 rpm  
 Swing torque..... 2991 kg.m **21,627 ft lbs**



## UNDERCARRIAGE

Center frame..... X-frame leg  
 Track frame..... Box-section  
 Track type..... Sealed track  
 Track adjuster..... Hydraulic  
 Number of shoes (each side)..... 46  
 Number of carrier rollers (each side)..... 2  
 Number of track rollers (each side)..... 8



## COOLANT & LUBRICANT CAPACITY (REFILLING)

Fuel tank..... 200 ltr **52.8 U.S. gal**  
 Coolant..... 17.7 ltr **4.6 U.S. gal**  
 Engine..... 11.5 ltr **3.0 U.S. gal**  
 Final drive, each side..... 2.1 ltr **.55 U.S. gal**  
 Swing drive..... 2.5 ltr **0.7 U.S. gal**  
 Hydraulic tank..... 69.0 ltr **18.2 U.S. gal**  
 DEF tank..... 12.6 ltr **3.3 U.S. gal**



## OPERATING WEIGHT (APPROXIMATE)

Operating weight includes 4600 mm **15'1"** one-piece boom, 2500 mm **8'2"** arm, SAE heaped 0.51 m<sup>3</sup> **0.67 yd<sup>3</sup>** backhoe bucket, rated capacity of lubricants, coolant, full fuel tank, operator, and standard equipment.

Triple-Grouser	Operating Weight	Ground Pressure ISO 16754
<b>Road Liner</b>		
500 mm 20"	15682 kg <b>34,563 lb</b>	45.29 kPa / 0.46 kg/cm <sup>2</sup> <b>6.57 psi</b>
600 mm 24"	15732 kg <b>34,673 lb</b>	37.86 kPa / 0.39 kg/cm <sup>2</sup> <b>5.49 psi</b>
700 mm 28"	15932 kg <b>35,114 lb</b>	32.87 kPa / 0.34 kg/cm <sup>2</sup> <b>4.77 psi</b>

### Component Weights

#### Arm including bucket cylinder and linkage

2500 mm **8'2"** arm assembly..... 529 kg **1,164 lb**  
 2500 mm **8'2"** arm assembly w/piping..... 558 kg **1,228 lb**  
 3000 mm **9'10"** arm assembly..... 643 kg **1,415 lb**  
 3000 mm **9'10"** arm assembly w/piping..... 678 kg **1,492 lb**

#### One piece boom including arm cylinder

4600 mm **15'1"** boom..... 962 kg **2,118 lb**

**Counterweight**..... 3460 kg **7,630 lb**

**Blade** including blade cylinders..... 848 kg **1,870 lb**

**Bucket** 0.51 m<sup>3</sup> **0.67 yd<sup>3</sup>** 762 mm **30"** width..... 517 kg **1,140 lb**

\* Auxiliary flow is adjustable through the monitor.





## DIMENSIONS

	Arm Length	2500 mm	8'2"	3000 mm	9'10"
	Boom length	4600 mm	15'1"	4600 mm	15'1"
<b>A</b>	Overall length	7385 mm	24'3"	7285 mm	23'11"
<b>B</b>	Overall height (to top of boom)*	2850 mm	9'4"	3210 mm	10'6"
<b>C</b>	Length on ground (transport)	4540 mm	14'11"	4400 mm	14'5"
<b>D</b>	Overall width	2590 mm	8'6"		
<b>E</b>	Overall height (to top of cab)*	2815 mm	9'3"		
<b>F</b>	Ground clearance, counterweight	900 mm	2'11"		
<b>G</b>	Ground clearance, minimum	395 mm	1'4"		
<b>H</b>	Tail swing radius	1545 mm	5'1"		
<b>I</b>	Track length on ground	3140 mm	10'4"		
<b>J</b>	Track length	3870 mm	12'8"		
<b>K</b>	Track gauge	1990 mm	6'6"		
<b>L</b>	Width of crawler	2590 mm	8'6"		
<b>M</b>	Shoe width	600 mm	24"		
<b>N</b>	Grouser height	20 mm	0.8"		
<b>O</b>	Machine height to top of counterweight	2140 mm	7'0"		
<b>P</b>	Machine upper width	2490 mm	8'2"		
<b>Q</b>	Distance, swing center to rear end	1545 mm	5'1"		

\* : Including grouser height

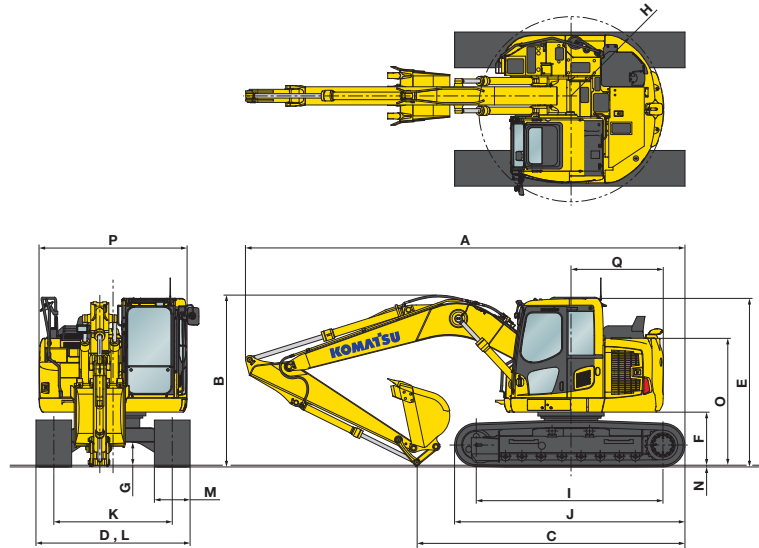

Blade ..... 2590mm **8'6"** wide x 590mm **1' 11"**



## BACKHOE BUCKET, ARM AND BOOM COMBINATION

Bucket Type	Bucket						Arms	
	Capacity		Width		Weight		2.5 m (8'2")	3.0 m (9'10")
Komatsu TL	0.26 m <sup>3</sup>	<b>0.34 yd<sup>3</sup></b>	457 mm	<b>18"</b>	332 kg	<b>732 lb</b>	V	V
	0.38 m <sup>3</sup>	<b>0.50 yd<sup>3</sup></b>	610 mm	<b>24"</b>	387 kg	<b>853 lb</b>	V	V
	0.51 m <sup>3</sup>	<b>0.67 yd<sup>3</sup></b>	762 mm	<b>30"</b>	437 kg	<b>963 lb</b>	V	V
	0.63 m <sup>3</sup>	<b>0.83 yd<sup>3</sup></b>	914 mm	<b>36"</b>	499 kg	<b>1,099 lb</b>	W	X
	0.76 m <sup>3</sup>	<b>1.00 yd<sup>3</sup></b>	1067 mm	<b>42"</b>	559 kg	<b>1,232 lb</b>	X	Y
Komatsu HP	0.26 m <sup>3</sup>	<b>0.34 yd<sup>3</sup></b>	457 mm	<b>18"</b>	379 kg	<b>836 lb</b>	V	V
	0.31 m <sup>3</sup>	<b>0.40 yd<sup>3</sup></b>	508 mm	<b>20"</b>	396 kg	<b>873 lb</b>	V	V
	0.38 m <sup>3</sup>	<b>0.50 yd<sup>3</sup></b>	610 mm	<b>24"</b>	457 kg	<b>1,007 lb</b>	V	V
	0.51 m <sup>3</sup>	<b>0.67 yd<sup>3</sup></b>	762 mm	<b>30"</b>	517 kg	<b>1,140 lb</b>	V	W
	0.63 m <sup>3</sup>	<b>0.83 yd<sup>3</sup></b>	914 mm	<b>36"</b>	591 kg	<b>1,303 lb</b>	W	X
Komatsu HPS	0.76 m <sup>3</sup>	<b>1.00 yd<sup>3</sup></b>	1067 mm	<b>42"</b>	664 kg	<b>1,464 lb</b>	Y	Z
	0.26 m <sup>3</sup>	<b>0.34 yd<sup>3</sup></b>	457 mm	<b>18"</b>	406 kg	<b>895 lb</b>	V	V
	0.31 m <sup>3</sup>	<b>0.40 yd<sup>3</sup></b>	508 mm	<b>20"</b>	426 kg	<b>939 lb</b>	V	V
	0.38 m <sup>3</sup>	<b>0.50 yd<sup>3</sup></b>	610 mm	<b>24"</b>	493 kg	<b>1,086 lb</b>	V	V
	0.51 m <sup>3</sup>	<b>0.67 yd<sup>3</sup></b>	762 mm	<b>30"</b>	562 kg	<b>1,240 lb</b>	V	W
	0.63 m <sup>3</sup>	<b>0.83 yd<sup>3</sup></b>	914 mm	<b>36"</b>	645 kg	<b>1,423 lb</b>	X	Y
	0.76 m <sup>3</sup>	<b>1.00 yd<sup>3</sup></b>	1067 mm	<b>42"</b>	728 kg	<b>1,605 lb</b>	Y	Z

V - Used with material weights up to 3,500 lb/yd<sup>3</sup>  
 X - Used with material weights up to 2,500 lb/yd<sup>3</sup>  
 Z - Not useable

W - Used with material weights up to 3,000 lb/yd<sup>3</sup>  
 Y - Used with material weights up to 2,000 lb/yd<sup>3</sup>

# SPECIFICATIONS



## WORKING RANGE

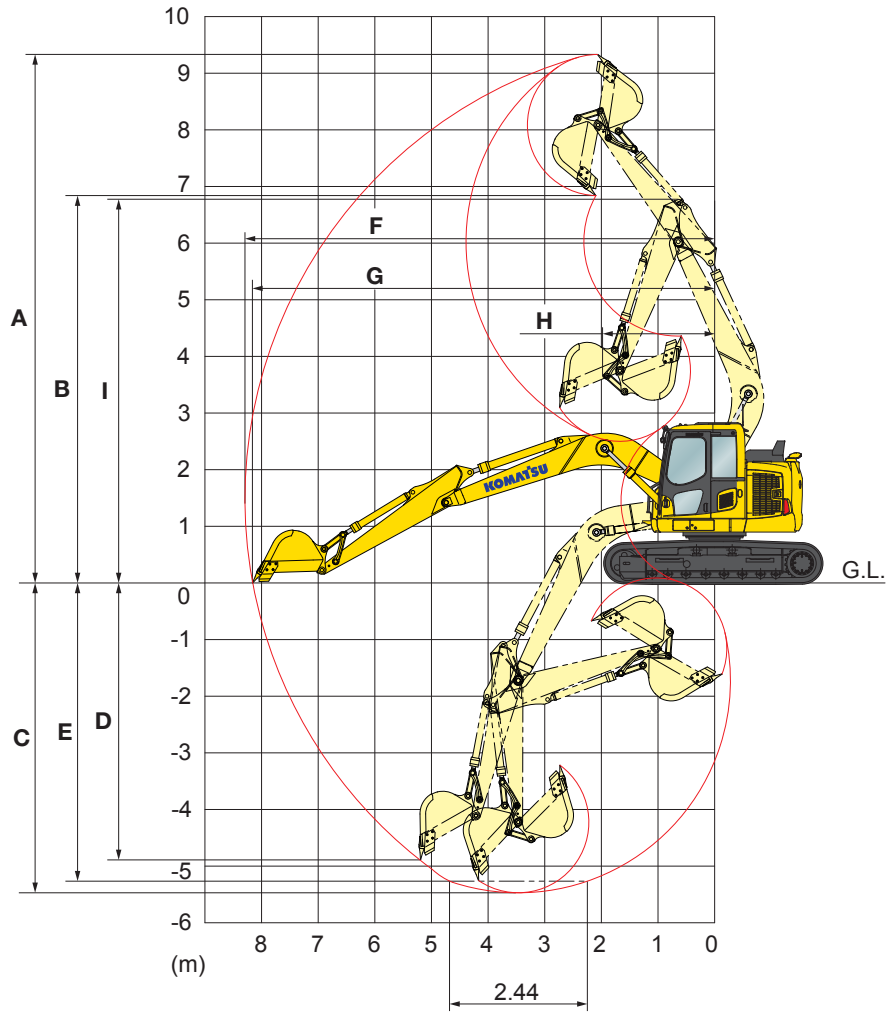

		Arm Length		2500 mm	8'2"	3000 mm	9'10"
<b>A</b>	Max. digging height	9340 mm	30'8"	9700 mm	31'10"		
<b>B</b>	Max. dumping height	6840 mm	22'5"	7350 mm	24'1"		
<b>C</b>	Max. digging depth	5480 mm	18'0"	5900 mm	19'4"		
<b>D</b>	Max. vertical wall digging depth	4900 mm	16'1"	5340 mm	17'6"		
<b>E</b>	Max. digging depth for 8' level bottom	5265 mm	17'3"	5715 mm	18'9"		
<b>F</b>	Max. digging reach	8300 mm	27'3"	8720 mm	28'7"		
<b>G</b>	Max. digging reach at ground level	8180 mm	26'10"	8600 mm	28'3"		
<b>H</b>	Min. swing radius	1980 mm	6'6"	2264 mm	7'5"		
<b>I</b>	Max. height at min. swing radius	6770 mm	22'3"	6770 mm	22'3"		
<b>SAE rating</b>	Bucket digging force	81.4 kN 8300 kg / 18,300 lb		78.0 kN 7950 kg / 17,530 lb			
	Arm crowd force	60.8 kN 6200 kgf / 13,670 lb		54.4 kN 5550 kgf / 12,235 lb			
<b>ISO rating</b>	Bucket digging force	93.2 kN 9500 kg / 20,945 lb		88.3 kN 9000 kg / 19,840 lb			
	Arm crowd force	61.8 kN 6300 kgf / 13,890 lb		55.9 kN 5700 kgf / 12,570 lb			

# LIFT CAPACITIES



## LIFTING CAPACITY WITH LIFTING MODE

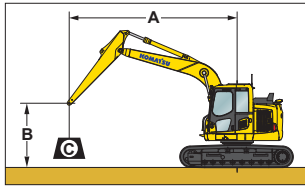

- A: Reach from swing center
- B: Bucket hook height
- C: Lifting capacity
- Cf: Rating over front
- Cs: Rating over side
- ☉: Rating at maximum reach

- Conditions:
- 4600 mm 15' 1" one-piece boom
  - Counterweight (total mass): 3460 kg 7,630 lb
  - Bucket: None
  - Lifting mode: On

Arm: 2500 mm 8'2" Shoes: 500 mm 20" triple grouser Blade: No Blade Unit: kg lb

B	A		1.5 m 5'		3.0 m 10'		4.6 m 15'		6.1 m 20'		7.6 m 25'		☉ MAX	
	Cf	Cs	Cf	Cs	Cf	Cs	Cf	Cs	Cf	Cs	Cf	Cs	Cf	Cs
7.6 m 25'			* 3470	* 3470									* 2500	* 2500
			* 7650	* 7650									* 5510	* 5510
6.1 m 20'					* 3360	* 3360							* 2010	* 2010
					* 7420	* 7420							* 4430	* 4430
4.6 m 15'					* 3730	* 3730	* 3010	2490					* 1870	* 1870
					* 8220	* 8220	* 6650	5500					* 4140	* 4140
3.0 m 10'			* 6000	* 6000	* 4600	3730	3890	2440					* 1870	* 1870
			* 13230	* 13230	* 10150	8230	8590	5380					* 4140	* 4140
1.5 m 5'			* 8460	6340	* 5570	3510	3790	2350					* 1980	1820
			* 18660	13980	* 12290	7750	8370	5180					* 4370	4010
0 m 0'			* 5730	* 5970	5680	3350	3700	2270					* 2210	1830
			* 14850	* 13160	12540	7380	8157	5010					* 4880	4050
-1.5 m -5'	* 3920	* 3920	* 9030	5910	5500	3270	3660	2230					* 2880	2000
	* 8640	* 8640	* 19920	13030	12340	7210	8080	4920					* 5920	4420
-3.0 m -10'	* 7540	* 7540	* 7570	5980	* 5240	3290							* 3790	2470
	* 16620	* 16620	* 16700	13200	* 11570	7260							* 8350	5460

Arm: 2500 mm 8'2" Shoes: 500 mm 20" triple grouser Blade: Blade Included - Blade on Ground Unit: kg lb

B	A		1.5 m 5'		3.0 m 10'		4.6 m 15'		6.1 m 20'		7.6 m 25'		☉ MAX	
	Cf	Cs	Cf	Cs	Cf	Cs	Cf	Cs	Cf	Cs	Cf	Cs	Cf	Cs
7.6 m 25'			* 3470	* 3470									* 2500	* 2500
			* 7650	* 7650									* 5510	* 5510
6.1 m 20'					* 3360	* 3360							* 2010	* 2010
					* 7420	* 7420							* 4430	* 4430
4.6 m 15'					* 3730	* 3730	* 3010	2530					* 1870	* 1870
					* 8220	* 8220	* 6650	5800					* 4140	* 4140
3.0 m 10'			* 6000	* 6000	* 4600	3920	* 3950	2570					* 1870	* 1870
			* 13260	* 13260	* 10150	8660	* 8710	5680					* 4140	* 4140
1.5 m 5'			* 8460	6680	* 5570	3710	* 4320	2480					* 1980	1930
			* 18660	14730	* 12290	8180	* 9520	5480					* 4370	4250
0 m 0'			* 6730	* 6310	* 6150	3540	* 4560	2400					* 2210	1950
			* 14850	* 13920	* 13580	7810	* 10050	5310					* 4880	4300
-1.5 m -5'	* 3920	* 3920	* 9030	6250	* 6100	3460	* 4390	2370					* 2680	2130
	* 8640	* 8640	* 19920	13780	* 13440	7640	* 9690	5220					* 5920	4590
-3.0 m -10'	* 7540	* 7540	* 7570	6330	* 5240	3480							* 3790	2620
	* 16620	* 16620	* 16700	13950	* 11570	7690							* 8350	5790

Arm: 3000 mm 9'10" Shoes: 500 mm 20" triple grouser Blade: No Blade Unit: kg lb

B	A		1.5 m 5'		3.0 m 10'		4.6 m 15'		6.1 m 20'		7.6 m 25'		☉ MAX	
	Cf	Cs	Cf	Cs	Cf	Cs	Cf	Cs	Cf	Cs	Cf	Cs	Cf	Cs
7.6 m 25'					* 2060	* 2060							* 1980	* 1980
					* 4550	* 4550							* 4380	* 4380
6.1 m 20'					* 2960	* 2960	* 1860	* 1860					* 1660	* 1660
					* 6520	* 6520	* 4100	* 4100					* 3670	* 3670
4.6 m 15'					* 2990	* 2990	* 2910	2500					* 1560	* 1560
					* 6600	* 6600	* 6420	5510					* 3430	* 3430
3.0 m 10'			* 3850	* 3850	* 3680	* 3680	* 3470	2430	* 1650	* 1650	* 1550	* 1550	* 1550	* 1550
			* 8500	* 8500	* 8110	* 8110	* 7650	5360	* 3640	* 3640	* 3420	* 3420	* 3420	* 3420
1.5 m 5'			* 7590	6440	* 5180	3510	3770	2320	* 2410	1550	* 1620	1610	* 1620	1610
			* 16740	14210	* 11420	7740	8320	5120	* 5310	3670	* 3580	3550	* 3580	3550
0 m 0'			* 7920	5940	5650	3310	3660	2220	* 2300	1620	* 1780	1620	* 1780	1620
			* 17460	13100	12470	7290	8080	4900	* 5070	3580	* 3940	3570	* 3940	3570
-1.5 m -5'	* 3520	* 3520	* 8510	5780	5520	3190	3600	2160			* 2100	1740	* 2100	1740
	* 7770	* 7770	* 18760	12750	12180	7050	7940	4770			* 4640	3850	* 4640	3850
-3.0 m -10'	* 7130	* 7130	* 8150	5830	5490	3190	3610	2170			* 2780	2080	* 2780	2080
	* 15710	* 15710	* 17970	12860	12120	7040	7950	4790			* 6130	4600	* 6130	4600
-4.6 m -15'			* 5710	* 5710	* 3680	3300					* 3190	3070	* 3190	3070
			* 12600	* 12600	* 8120	7280					* 7050	6780	* 7050	6780

\*Load is limited by hydraulic capacity rather than tipping. Ratings are based on ISO standard No. 10567. Rated loads do not exceed 87% of hydraulic lift capacity or 75% of tipping load.

# LIFT CAPACITIES



## LIFTING CAPACITY WITH LIFTING MODE

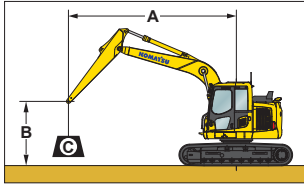

- A: Reach from swing center
- B: Bucket hook height
- C: Lifting capacity
- Cf: Rating over front
- Cs: Rating over side
- ⊗: Rating at maximum reach

Conditions:

- 4600 mm 15' 1" one-piece boom
- Counterweight (total mass): 3460 kg 7,630 lb
- Bucket: None
- Lifting mode: On

Arm: 3000 mm 9'10" Shoes: 500 mm 20" triple grouser Blade: Blade Included - Blade on Ground Unit: kg lb

B	A		1.5 m 5'		3.0 m 10'		4.6 m 15'		6.1 m 20'		7.6 m 25'		⊗ MAX	
	Cf	Cs	Cf	Cs	Cf	Cs	Cf	Cs	Cf	Cs	Cf	Cs	Cf	Cs
7.6 m							* 2060	* 2060					* 1980	* 1980
25'							* 4550	* 4550					* 4380	* 4380
6.1 m							* 2960	* 2960	* 1860	* 1860			* 1660	* 1660
20'							* 6520	* 6520	* 4100	* 4100			* 3670	* 3670
4.6 m							* 2990	* 2990	* 2910	2630			* 1560	* 1560
15'							* 6600	* 6600	* 6420	5810			* 3430	* 3430
3.0 m			* 3850	* 3850	* 3680	* 3680	* 3470	2560	* 1650	* 1650	* 1550	* 1550		
10'			* 8500	* 8500	* 8110	* 8110	* 7650	5660	* 3640	* 3640	* 3420	* 3420		
1.5 m			* 7590	6780	* 5180	3700	* 4070	2560	* 2410	1770	* 1620	* 1620		
5'			* 15740	14950	* 11420	8170	* 8980	5660	* 5310	3900	* 3580	* 3580		
0 m			* 7920	6280	* 5940	3500	* 4420	2360	* 2300	1730	* 1780	1720		
0'			* 17460	13850	* 13110	7720	* 9740	5200	* 5070	3810	* 3940	3800		
-1.5 m	* 3520	* 3520	* 8510	6130	* 6070	3390	* 4430	2300			* 2100	1860		
-5'	* 7770	* 7770	* 18760	13510	* 13400	7480	* 9770	5070			* 4640	4100		
-3.0 m	* 7130	* 7130	* 8150	6170	* 5540	3380	* 3770	2310			* 2780	2210		
-10'	* 15710	* 15710	* 17970	13610	* 12220	7460	* 8320	5090			* 6130	4880		
-4.6 m			* 5710	* 5710	* 3680	* 3460					* 3190	* 3190		
-15'			* 12600	* 12600	* 8120	* 7640					* 7050	* 7050		

Arm: 2500 mm 8'2" Shoes: 600 mm 24" triple grouser Blade: No Blade Unit: kg lb

B	A		1.5 m 5'		3.0 m 10'		4.6 m 15'		6.1 m 20'		7.6 m 25'		⊗ MAX	
	Cf	Cs	Cf	Cs	Cf	Cs	Cf	Cs	Cf	Cs	Cf	Cs	Cf	Cs
7.6 m					* 3470	* 3470							* 2500	* 2500
25'					* 7650	* 7650							* 5510	* 5510
6.1 m							* 3360	* 3360					* 2010	* 2010
20'							* 7420	* 7420					* 4430	* 4430
4.6 m							* 3730	* 3730	* 3010	2520			* 1870	* 1870
15'							* 8220	* 8220	* 6650	5560			* 4140	* 4140
3.0 m			* 6000	* 6000	* 4600	3770	3940	2470			* 1870	* 1870		
10'			* 13230	* 13230	* 10150	8320	8590	5440			* 4140	* 4140		
1.5 m			* 8450	6410	* 5570	3550	3840	2380			* 1980	1840		
5'			* 18650	14130	* 12290	7840	8470	5250			* 4370	4060		
0 m			* 6730	6040	5750	3390	3750	2300			* 2210	1860		
0'			* 14850	13320	* 12690	7470	8270	5070			* 4880	4100		
-1.5 m	* 3920	* 3920	* 9030	5980	5660	3310	3710	2260			* 2680	2030		
-5'	* 8640	* 8640	* 19920	13190	12490	7300	8180	4990			* 5920	4480		
-3.0 m	* 7540	* 7540	* 7570	6060	* 5240	3330					* 3790	2510		
-10'	* 16620	* 16620	* 16700	13360	* 11570	7350					* 8350	5530		

Arm: 2500 mm 8'2" Shoes: 600 mm 24" triple grouser Blade: Blade Included - Blade on Ground Unit: kg lb

B	A		1.5 m 5'		3.0 m 10'		4.6 m 15'		6.1 m 20'		7.6 m 25'		⊗ MAX	
	Cf	Cs	Cf	Cs	Cf	Cs	Cf	Cs	Cf	Cs	Cf	Cs	Cf	Cs
7.6 m					* 3470	* 3470							* 2500	* 2500
25'					* 7650	* 7650							* 5510	* 5510
6.1 m							* 3360	* 3360					* 2010	* 2010
20'							* 7420	* 7420					* 4430	* 4430
4.6 m							* 3730	* 3730	* 3010	2650			* 1870	* 1870
15'							* 8220	* 8220	* 6650	5960			* 4140	* 4140
3.0 m			* 6000	* 6000	* 4600	3970	* 3950	2600			* 1870	* 1870		
10'			* 13230	* 13230	* 10150	8750	* 8710	5740			* 4140	* 4140		
1.5 m			* 8460	6750	* 5570	3750	* 4320	2510			* 1980	1950		
5'			* 18660	14890	* 12290	8270	* 9520	5540			* 4370	4300		
0 m			* 6730	* 6380	* 6160	3880	* 4560	2430			* 2210	1970		
0'			* 14850	* 14070	* 13580	7900	* 10050	5370			* 4880	4350		
-1.5 m	* 3920	* 3920	* 9030	6320	* 6100	3500	* 4390	2390			* 2680	2150		
-5'	* 8640	* 8640	* 19920	13940	* 13440	7730	* 9690	5280			* 5920	4750		
-3.0 m	* 7540	* 7540	* 7670	6400	* 5240	3520					* 3790	2650		
-10'	* 16620	* 16620	* 16700	14110	* 11570	7780					* 8350	5860		

\*Load is limited by hydraulic capacity rather than tipping. Ratings are based on ISO standard No. 10567. Rated loads do not exceed 87% of hydraulic lift capacity or 75% of tipping load.



## LIFTING CAPACITY WITH LIFTING MODE

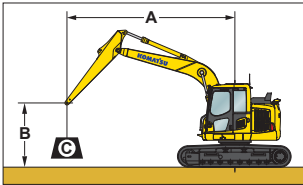

- A: Reach from swing center
- B: Bucket hook height
- C: Lifting capacity
- Cf: Rating over front
- Cs: Rating over side
- ⊗: Rating at maximum reach

- Conditions:
- 4600 mm **15' 1"** one-piece boom
  - Counterweight (total mass): 3460 kg **7,630 lb**
  - Bucket: None
  - Lifting mode: On

Arm: 3000 mm 9'10" Shoes: 600 mm 24" triple grouser Blade: No Blade Unit: kg lb

B	A		3.0 m 10'		4.6 m 15'		6.1 m 20'		7.6 m 25'		⊗ MAX	
	1.5 m 5'		Cf	Cs	Cf	Cs	Cf	Cs	Cf	Cs	Cf	Cs
7.6 m					* 2060	* 2060					* 1980	* 1980
25'					* 4550	* 4550					* 4380	* 4380
6.1 m					* 2960	* 2960	* 1860	* 1860			* 1660	* 1660
20'					* 6520	* 6520	* 4100	* 4100			* 3670	* 3670
4.6 m					* 2990	* 2990	* 2910	2530			* 1560	* 1560
15'					* 6660	* 6660	* 6420	5580			* 3430	* 3430
3.0 m			* 3850	* 3850	* 3680	* 3680	* 3470	2460	* 1650	* 1650	* 1550	* 1550
10'			* 8500	* 8500	* 8110	* 8110	* 7550	5420	* 3640	* 3640	* 3420	* 3420
1.5 m			* 7590	6510	* 5180	3550	3820	2350	* 2410	1680	* 1620	* 1620
5'			* 16740	14360	* 11420	7830	8420	5190	* 5310	3720	* 3580	* 3580
0 m			* 7920	6010	* 5720	3350	3710	2250	* 2300	1640	* 1780	1640
0'			* 17460	13260	* 12620	7380	8180	4970	* 5070	3630	* 3940	3620
-1.5 m	* 3520	* 3520	* 8510	5850	5590	3240	3640	2190			* 2100	1770
-5'	* 7770	* 7770	* 18760	12910	12330	7140	8040	4840			* 4640	3900
-3.0 m	* 7130	* 7130	* 8150	5900	* 5540	3230	3650	2200			* 2780	2110
-10'	* 15710	* 15710	* 17970	13010	* 12220	7130	8050	4850			* 5130	4660
-4.6 m			* 5710	* 5710	* 3680	3340					* 3190	3110
-15'			* 12600	* 12600	* 8120	7370					* 7050	6850

\*Load is limited by hydraulic capacity rather than tipping. Ratings are based on ISO standard No. 10567. Rated loads do not exceed 87% of hydraulic lift capacity or 75% of tipping load.

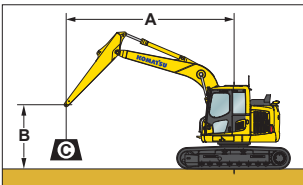

- A: Reach from swing center
- B: Bucket hook height
- C: Lifting capacity
- Cf: Rating over front
- Cs: Rating over side
- ⊗: Rating at maximum reach

- Conditions:
- 4600 mm **15' 1"** one-piece boom
  - Counterweight (total mass): 3460 kg **7,630 lb**
  - Bucket: None
  - Lifting mode: On

Arm: 3000 mm 9'10" Shoes: 600 mm 24" triple grouser Blade: Blade Included - Blade on Ground Unit: kg lb

B	A		3.0 m 10'		4.6 m 15'		6.1 m 20'		7.6 m 25'		⊗ MAX	
	1.5 m 5'		Cf	Cs	Cf	Cs	Cf	Cs	Cf	Cs	Cf	Cs
7.6 m					* 2060	* 2060					* 1980	* 1980
25'					* 4550	* 4550					* 4380	* 4380
6.1 m					* 2960	* 2960	* 1860	* 1860			* 1660	* 1660
20'					* 6520	* 6520	* 4100	* 4100			* 3670	* 3670
4.6 m					* 2990	* 2990	* 2910	2660			* 1560	* 1560
15'					* 6600	* 6600	* 6420	5870			* 3430	* 3430
3.0 m			* 3850	* 3850	* 3880	* 3880	* 3470	2590	* 1650	* 1650	* 1550	* 1550
10'			* 8500	* 8500	* 8110	* 8110	* 7650	5720	* 3640	* 3640	* 3420	* 3420
1.5 m			* 7590	6860	* 5180	3740	* 4070	2480	* 2410	1790	* 1620	* 1620
5'			* 16740	15120	* 11420	8260	* 8980	5480	* 5310	3950	* 3580	* 3580
0 m			* 7920	6350	* 5940	3540	* 4420	2390	* 2300	1750	* 1780	1740
0'			* 17460	14010	* 13110	7810	* 9740	5260	* 5070	3860	* 3940	3850
-1.5 m	* 3520	* 3520	* 8510	6200	* 6070	3430	* 4430	2330			* 2100	1880
-5'	* 7770	* 7770	* 18760	13670	* 13400	7570	* 9770	5140			* 4640	4150
-3.0 m	* 7130	* 7130	* 8150	6240	* 5540	3420	* 3770	2330			* 2780	2240
-10'	* 15710	* 15710	* 17970	13770	* 12220	7550	* 8320	5150			* 6130	4940
-4.6 m			* 5710	* 5710	* 3680	3500					* 3190	3190
-15'			* 12600	* 12600	* 8120	7720					* 7050	7050

\*Load is limited by hydraulic capacity rather than tipping. Ratings are based on ISO standard No. 10567. Rated loads do not exceed 87% of hydraulic lift capacity or 75% of tipping load.

# LIFT CAPACITIES



## LIFTING CAPACITY WITH LIFTING MODE

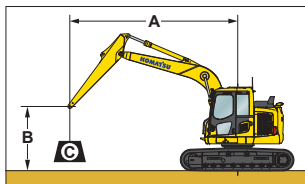

- A: Reach from swing center
- B: Bucket hook height
- C: Lifting capacity
- Cf: Rating over front
- Cs: Rating over side
- ⊗: Rating at maximum reach

- Conditions:
- 4600 mm 15' 1" one-piece boom
  - Counterweight (total mass): 3460 kg 7,630 lb
  - Bucket: None
  - Lifting mode: On

Arm: 2500 mm 8'2" Shoes: 700 mm 28" triple grouser Blade: No Blade

Unit: kg lb

B	A		1.5 m 5'		3.0 m 10'		4.6 m 15'		6.1 m 20'		7.6 m 25'		⊗ MAX	
	Cf	Cs	Cf	Cs	Cf	Cs	Cf	Cs	Cf	Cs	Cf	Cs	Cf	Cs
7.6 m 25'			* 3470	* 3470									* 2500	* 2500
			* 7650	* 7650									* 5510	* 5510
6.1 m 20'					* 3360	* 3360							* 2010	* 2010
					* 7420	* 7420							* 4430	* 4430
4.6 m 15'					* 3730	* 3730	* 3010	2550					* 1870	* 1870
					* 8220	* 8220	* 6650	5630					* 4140	* 4140
3.0 m 10'			* 6000	* 6000	* 4600	3820	* 3950	2500					* 1870	* 1870
			* 13230	* 13230	* 10150	8420	* 8710	5510					* 4140	* 4140
1.5 m 5'			* 8460	* 8460	* 5570	3600	3890	2410					* 1980	1860
			* 18660	* 18660	* 12290	7940	8580	5320					* 4370	4120
0 m 0'			* 6730	* 6120	5830	3430	3800	2380					* 2210	1880
			* 14850	* 13490	12860	7570	8390	5140					* 4880	4160
-1.5 m -5'	* 3920	* 3920	* 9030	6060	5740	3360	3760	2290					* 2690	2050
	* 8640	* 8640	* 19920	13360	12660	7400	8290	5050					* 5920	4540
-3.0 m -10'	* 7540	* 7540	* 7560	6140	* 5240	3380							* 3790	2540
	* 16520	* 16520	* 16700	13530	* 11570	7450							* 8350	5610
-4.6 m -15'														

\*Load is limited by hydraulic capacity rather than tipping. Ratings are based on ISO standard No. 10567. Rated loads do not exceed 87% of hydraulic lift capacity or 75% of tipping load.

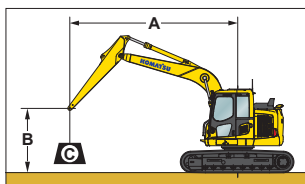

- A: Reach from swing center
- B: Bucket hook height
- C: Lifting capacity
- Cf: Rating over front
- Cs: Rating over side
- ⊗: Rating at maximum reach

- Conditions:
- 4600 mm 15' 1" one-piece boom
  - Counterweight (total mass): 3460 kg 7,630 lb
  - Bucket: None
  - Lifting mode: On

Arm: 2500 mm 8'2" Shoes: 700 mm 28" triple grouser Blade: Blade Included - Blade on Ground

Unit: kg lb

B	A		1.5 m 5'		3.0 m 10'		4.6 m 15'		6.1 m 20'		7.6 m 25'		⊗ MAX	
	Cf	Cs	Cf	Cs	Cf	Cs	Cf	Cs	Cf	Cs	Cf	Cs	Cf	Cs
7.6 m 25'			* 3470	* 3470									* 2500	* 2500
			* 7650	* 7650									* 5510	* 5510
6.1 m 20'					* 3360	* 3360							* 2010	* 2010
					* 7420	* 7420							* 4430	* 4430
4.6 m 15'					* 3730	* 3730	* 3010	2690					* 1870	* 1870
					* 8220	* 8220	* 6650	5930					* 4140	* 4140
3.0 m 10'			* 6000	* 6000	* 4600	4010	* 3950	2630					* 1870	* 1870
			* 13200	* 13200	* 10150	8850	* 8710	5810					* 4140	* 4140
1.5 m 5'			* 8460	6830	* 5570	3790	* 4320	2540					* 1980	1970
			* 18660	15070	* 12290	8370	* 9520	5610					* 4370	4360
0 m 0'			* 6730	* 6480	* 6160	3630	* 4560	2460					* 2210	2000
			* 14850	* 14250	* 13580	8000	* 10050	5440					* 4880	4410
-1.5 m -5'	* 3920	* 3920	* 9030	6400	* 6100	3550	* 4390	2430					* 2680	2180
	* 8640	* 8640	* 19920	14120	* 13440	7830	* 9590	5350					* 5920	4810
-3.0 m -10'	* 7540	* 7540	* 7570	6480	* 5240	3570							* 3790	2690
	* 16620	* 16620	* 16700	14290	* 11570	7880							* 8350	5930
-4.6 m -15'														

\*Load is limited by hydraulic capacity rather than tipping. Ratings are based on ISO standard No. 10567. Rated loads do not exceed 87% of hydraulic lift capacity or 75% of tipping load.



## LIFTING CAPACITY WITH LIFTING MODE

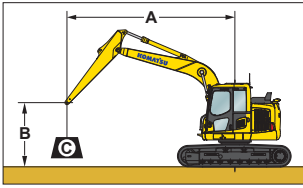

- A: Reach from swing center
- B: Bucket hook height
- C: Lifting capacity
- Cf: Rating over front
- Cs: Rating over side
- ⊗: Rating at maximum reach

- Conditions:
- 4600 mm 15' 1" one-piece boom
  - Counterweight (total mass): 3460 kg 7,630 lb
  - Bucket: None
  - Lifting mode: On

Arm: 3000 mm 9'10" Shoes: 700 mm 28" triple grouser Blade: No Blade Unit: kg lb

B	A		1.5 m 5'		3.0 m 10'		4.6 m 15'		6.1 m 20'		7.6 m 25'		⊗ MAX	
	Cf	Cs	Cf	Cs	Cf	Cs	Cf	Cs	Cf	Cs	Cf	Cs	Cf	Cs
7.6 m 25'					* 2060	* 2060							* 1980	* 1980
					* 4550	* 4550							* 4380	* 4380
6.1 m 20'					* 2960	* 2960	* 1860	* 1860					* 1660	* 1660
					* 6520	* 6520	* 4100	* 4100					* 3670	* 3670
4.6 m 15'					* 2990	* 2990	* 2910	2560					* 1560	* 1560
					* 6500	* 6500	* 6420	5650					* 3430	* 3430
3.0 m 10'			* 3850	* 3850	* 3680	* 3680	* 3470	2490	* 1650	* 1650	* 1550	* 1550	* 3420	* 3420
			* 8500	* 8500	* 8110	* 8110	* 7650	5490	* 3640	* 3640	* 3420	* 3420		
1.5 m 5'			* 7590	6590	* 5180	3590	3870	2380	* 2410	1710	* 1620	* 1620		
			* 16740	14540	* 11420	7930	8540	5250	* 5310	3770	* 3580	* 3580		
0 m 0'			* 7920	6090	5800	3390	3760	2280	* 2900	1670	* 1780	1660		
			* 17460	13490	* 12790	7480	8290	5030	* 5070	3680	* 3940	3670		
-1.5 m -5'	* 3520	* 3520	* 8510	5930	5670	3280	3690	2220			* 2100	1790		
	* 7770	* 7770	* 18760	13090	12500	7240	8150	4910			* 4640	3960		
-3.0 m -10'	* 7130	* 7130	* 8150	5980	* 5540	3270	3700	2230			* 2780	2140		
	* 15710	* 15710	* 17970	13190	* 12220	7230	8170	4920			* 6130	4720		
-4.6 m -15'			* 5710	* 5710	* 3680	3380					* 3190	3150		
			* 12600	* 12600	* 8120	7470					* 7050	5960		

\*Load is limited by hydraulic capacity rather than tipping. Ratings are based on ISO standard No. 10567. Rated loads do not exceed 87% of hydraulic lift capacity or 75% of tipping load.

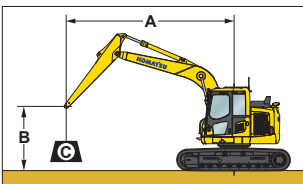

- A: Reach from swing center
- B: Bucket hook height
- C: Lifting capacity
- Cf: Rating over front
- Cs: Rating over side
- ⊗: Rating at maximum reach

- Conditions:
- 4600 mm 15' 1" one-piece boom
  - Counterweight (total mass): 3460 kg 7,630 lb
  - Bucket: None
  - Lifting mode: On

Arm: 3000 mm 9'10" Shoes: 700 mm 28" triple grouser Blade: Blade Included - Blade on Ground Unit: kg lb

B	A		1.5 m 5'		3.0 m 10'		4.6 m 15'		6.1 m 20'		7.6 m 25'		⊗ MAX	
	Cf	Cs	Cf	Cs	Cf	Cs	Cf	Cs	Cf	Cs	Cf	Cs	Cf	Cs
7.6 m 25'					* 2980	* 2980							* 1980	* 1980
					* 6520	* 6520							* 4380	* 4380
6.1 m 20'					* 2060	* 2060	* 1860	* 1860					* 1660	* 1660
					* 4550	* 4550	* 4100	* 4100					* 3670	* 3670
4.6 m 15'					* 2990	* 2990	* 2910	2690					* 1560	* 1560
					* 6600	* 6600	* 6420	5940					* 3430	* 3430
3.0 m 10'			* 3850	* 3850	* 3680	* 3680	* 3470	2620	* 1650	* 1650	* 1550	* 1550	* 3420	* 3420
			* 8500	* 8500	* 8110	* 8110	* 7650	5790	* 3640	* 3640	* 3420	* 3420		
1.5 m 5'			* 7590	6940	* 5180	3790	* 4070	2520	* 2410	1810	* 1620	* 1620		
			* 16740	15300	* 11420	8360	* 8980	5550	* 5310	4000	* 3580	* 3580		
0 m 0'			* 7920	6430	* 5940	3590	* 4420	2420	* 2300	1770	* 1780	1770		
			* 17460	14190	* 13110	7910	* 9740	5330	* 5070	3910	* 3940	3900		
-1.5 m -5'	* 3520	* 3520	* 8510	6280	* 6070	3470	* 4430	2360			* 2100	1910		
	* 7770	* 7770	* 18760	13840	* 13400	7670	* 9770	5200			* 4640	4210		
-3.0 m -10'	* 7130	* 7130	* 8150	6320	* 5540	3470	* 3770	2370			* 2780	2270		
	* 15710	* 15710	* 17970	13940	* 12220	7650	* 8320	5220			* 6130	5010		
-4.6 m -15'			* 5710	* 5710	* 3680	* 3550					* 3190	3190		
			* 12600	* 12600	* 8120	* 7820					* 7050	7050		

\*Load is limited by hydraulic capacity rather than tipping. Ratings are based on ISO standard No. 10567. Rated loads do not exceed 87% of hydraulic lift capacity or 75% of tipping load.



## STANDARD EQUIPMENT

### ENGINE

- Air cleaner, double element with auto dust evacuator
- Cooling fan, viscous type
- Debris guards for radiator and oil cooler
- Engine, Komatsu SAA4D95LE-7
- Engine overheat prevention system

### ELECTRICAL SYSTEM

- Alternator, 24 V/60 A
- Auto-decelerator
- Batteries, 2 x 12 V/72 Ah
- Electric horn
- Starting motor 24 V/4.5 kW
- Working light on boom
- Working lights on cab (2)

### HYDRAULIC SYSTEM

- Boom holding valve

### GUARDS AND COVERS

- Fan guard structure
- Handrails
- Pump/engine partition cover

### UNDERCARRIAGE

- Shoe, 600 mm **24"** triple grouser

### OPERATOR ENVIRONMENT

- 2 x 12 V power points
- 2 way multi-control valve
- 24 V - 12 V power converter
- Automatic A/C
- Auto idle shutdown function
- Auxiliary input jack
- Cab includes: antenna, AM/FM radio, floor mat, intermittent front windshield wiper and washer, large ceiling hatch, pull-up front window, removable lower windshield
- Foldable mirror (LH)
- Large high resolution LCD monitor
- Lock lever
- Mirror (Rear)
- Operator identification function
- Operator protective top guard, OPG level 1 (ISO 10262)
- Rear view monitor system
- ROPS cab (ISO 12117-2)
- Seat belt, 76 mm **3"**
- Suspension seat
- Swing holding brake

### OTHER

- Counterweight (total mass), 3460 kg **7,630 lb**
- Equipment management monitoring system
- KOMTRAX®
- Pattern change valve
- Rear reflector
- Travel alarm



## OPTIONAL EQUIPMENT

### HYDRAULIC SYSTEM

- Hydraulic control unit - 1 additional actuator (+ 1 Hydraulics) with one and two-way flow

### GUARDS AND COVERS

- Cab guard
  - Full front guard, OPG level 1 (ISO 10262)
  - Full front guard, OPG level 2 (ISO 10262)
  - Bolt-on top guard, OPG level 2 (ISO 10262)

### UNDERCARRIAGE

- Extended track frame steps for 700 mm **28"** tracks
- Shoes
  - 500 mm **20"** triple grouser
  - 700 mm **28"** triple grouser
  - 500 mm **20"** rubber roadliner

### OPERATOR ENVIRONMENT

- Sunvisor

### WORK EQUIPMENT

- Arms
  - 2500 mm **8'2"** arm assembly
  - 2500 mm **8'2"** arm assembly with piping
  - 3000 mm **9'10"** arm assembly
  - 3000 mm **9'10"** arm assembly with piping
- Booms
  - 4600 mm **15'1"** boom assembly
  - 4600 mm **15'1"** boom assembly with piping
- Blade
  - 2490 mm **8'6"** wide blade

# KOMATSU®

*Note: All comparisons and claims of improved performance made herein are made with respect to the prior Komatsu model unless otherwise specifically stated.*