



NEW HOLLAND

E215_B

NEW HOLLAND KOBELCO



NET FLYWHEEL POWER	118 kW - 158 hp
MAX OPERATING WEIGHT	23 310 kg
BUCKET CAPACITY	0.52 - 1.31 m ³

 **NEW HOLLAND**

CONSTRUCTION

BUILT AROUND YOU

The future i



s gold

Genius

- Fuel saving
- Productive
- Extended maintenance interval
5000 hours hydraulic oil
- Easy maintenance

Outstanding

- Styling
- Care for the environment
- Safety
- Operator comfort

Loyal

- Controllable
- Reliable
- Easy to operate
- Versatile

Durable

- Larger engine and pumps
@ lower rpm
- Robust structure
Higher D frame
- HD Booms and arms
- Longer tracks for better strength
and weight distribution



E215B* THE PE

TOP EFFICIENCY

Productivity (m³/l) +15%

- **BREAK-OUT FORCE**
(without/with powerboost)
bucket 155 kN /169 kN + 6%
dipper 152 kN /165 kN + 6%
- **LIFTING CAPACITY +10%**
- **POWERFUL SWING AND TRAVEL**
swing torque + 10 %
travel torque + 10 %



* A product of the global alliance between New Holland and KOBELCO

PERFORMANCE

SUPERIOR & SAFE DYNAMIC STABILITY

The whole structure of E215B has been redesigned, to guarantee a perfect match with its higher performances, by improving position of centre of gravity, by optimising stresses distribution and by adopting higher quality steel plates. To eliminate bumps and shocks to the whole structure when the pistons reach their stroke end, cylinders have been equipped with automatic recovery and cushioning systems. In addition the undercarriages of EL and L versions are now **9% longer**, thus effectively contributing to increased stability. **All this adds up to guarantee an excellent and safe machine with dynamic stability** when working in any kind of job and on all types of ground. This superb stability enhances the E215B **outstanding lifting capacity, increased by 10%**. **New Holland E215B features a Superior Breakout Force of 16900 daN or + 6%** which can be fully exploited, thanks to the weight strategically distributed in its structure, without unpleasant jumping effects.

C.P.B. (Continuous Power Boost)

Continuous Power Boost is a feature of excellence of the E215B.

Continuous Power Boost means that, if the operator is facing a very tough application, he can select this function (hydraulic pressure raises to 37.8 Mpa) **with no time limit**. Continuous Power Boost allows him to work without problems in job-site productivity and machine reliability. **A unique feature only offered by New Holland.**



E215B THE PO



RESPECTING THE ENVIRONMENT

The E215B is compliant with European Directives concerning electromagnetic compatibility and noise level. The emissions of the new Tier 3A CNH engine have been dramatically reduced and are, as shown below, much lower than standard requirements.

CO: 0.77, HC: 0.08, NOx: 3.59, Particulate: 0.13 (*)

In addition, this engine can use normal diesel, with up to **20% of Biodiesel added...**
...a real Environmentally Friendly machine.

(*) all data are expressed in g/kWh

POWER OF CONTROL



NEW CNH ENGINE

The new CNH, NEF generation, 6 cylinders, 6.7 litres, is a mechanical engine, developing a power of 118 kW at 2000 rpm and a torque of 665 Nm at only 1200 rpm... **an extremely flexible and responsive power plant.** A larger displacement engine working at lower revolution contributes to:

- Less noise and fuel consumption
- Longer lifespan
- Higher reliability



NEW HYDRAULIC PUMPS

The E215B is equipped with two new larger displacement hydraulic pumps able to supply a higher flow at lower rpm... **state-of-the-art pumps, easy to control and prompt to react to all requirements.**

ELECTRONIC CONTROL

Sensors are located in the pilot lines, sending signals to the on-board computer that are proportional to the manipulator's strokes. These signals are managed together with engine r.p.m. to tune the quantity of hydraulic oil requested to **guarantee extremely smooth and precise controls, excellent stability and steady speed during simultaneous operations.**



LOW EFFORT & PRECISE JOYSTICKS

All machine movements can be smoothly controlled by **low effort joysticks**... a real, effective **Control of Power** allowing longer work times with less fatigue. The joystick illustrated is supplied as an option, together with rotating bucket circuit.

E215B ADVANC



NEW HYDRAULIC SYSTEM

T EFFICIENCY AND CONTROLLABILITY

To obtain a Hydraulic System which is much more efficient, controllable, fast and powerful, and which consumes less fuel than previously, New Holland engineers have been working not only on pumps but also on a completely redesigned and refined Control Valve adding a second arm spool, larger radius pipings with SAE flange ports, increased swing output torque and new working mode selection functions. Movements speed has been increased and machine controllability improved, especially on operations that require combined movements.

This outstanding characteristic is further enhanced by the new **H.A.O.A. Control**.

H H.A.O.A. (Hydrotronic Active Operation Aid)

Hydrotronic Active Operation Aid is the most effective available combination of an extremely advanced electronic technology that provides a “just in time” comprehensive control of all machine functions, and a deeply refined and sophisticated hydraulic system.

H.A.O.A. continuously optimises hydraulic output according to operator and job demand, providing the best machine controllability, productivity, operator comfort and fuel savings.

ED HYDRAULIC SYSTEM

A.E.P. - (Advanced Electronic Processor)

A.E.P. is a new Electronic Processor that interacts with the operator for selecting and monitoring all main working parameters, maintenance notifications, self diagnosis and operating data storage.

All this information is displayed in the new monitor, which features a larger back-lit, easier to read digital display and analogic gauges.

Simply select the requested working mode and A.E.P. pre-sets the hydraulic system to accomplish the job in the easiest and most productive way:

- **S mode** for normal working operations
- **H mode** when maximum power is required
- **A mode** adjusts the attachment circuit for tools which require two way flow.

A dedicated switch on the dashboard, enables the operator to select two pumps oil flow

- **B mode** for attachments featuring one way flow only

Both in A and B working modes the operator, by using the buttons on the monitor, may adjust the flow by 10 l/min steps and the pressure by 10 bars steps to perfectly match the parameters of the attachment being used.

In addition, the operator can save to memory 9 combinations of flow and pressure in both A and B working modes, for a total of 18 combinations.

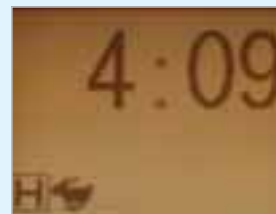
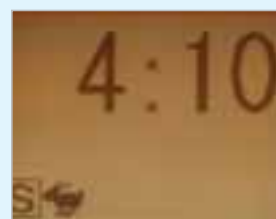

T D.O.C. (Dipperstick Optimised Control)

The newly redesigned Control Valve features a second spool dedicated to dipperstick operation. The movement "dipper out" is now achieved with a double flow, i.e., using the flow of the two pumps. The "dipper in" movement is even faster because of the double pump flow combined with the "Conflux", or recirculation of unused oil which is diverted from return to tank.

A perfect combination of speed, efficiency, precision and increased production.

E OBJECT HANDLING KIT

European Standards state rules of thumb that do not allow free interpretation to each European Country. In case of object handling operations, an excavator can be used **only if certified by manufacturer** that it is equipped with all safety devices required by European Standards EN 474-5 : 1996. New Holland, confirming its commitment to grant high performances in an extremely safe environment, offers its customers the **optional Object Handling Kit** for maximum operator confidence.

E215B HIGH RE

TOP DESIGN & PRODU

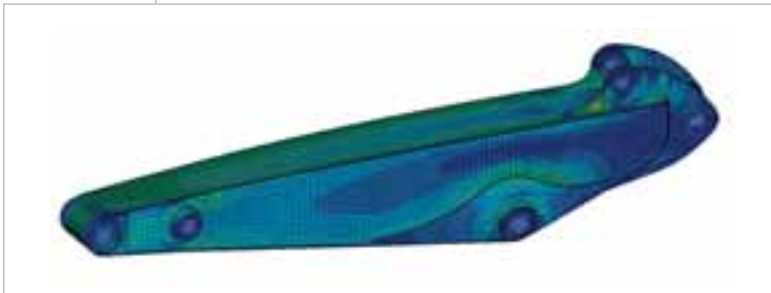

Booms and Arms have been redesigned using advanced CAD (Computer Aided Design) and FEM (Finite Elements Methodology) Systems to get higher strength **only** in those areas where stresses are concentrated.

These sophisticated design methodologies are combined with the most advanced production technologies, providing high tensile steel plates that are cut, assembled and welded at the New Holland plant, which since many years holds the prestigious "Vision 2000" Quality Certification.

The result is a lighter but stronger **Heavy Duty** front attachment to **load more earth...and less "dead" iron**. The same innovative guidelines, to achieve **Heavy Duty** maximum strength together with outstanding torsional and flexional resistance, are applied in design and manufacture of upper structure and the undercarriage.

BUCKET LINKAGE WITH DOUBLE BUSHING

The arm/bucket long-life internal bushing, now has extra protection from wear due to contact with the bucket linkage, thanks to new additional external bushings made from anti-wear steel material. When the radial surface is wearied this new bushings can be easily changed, thus increasing pin and bushing durability while reducing owning costs.



To further extend Arms durability even in rocky applications, New Holland offers as optional a robust Arm protection.



LIABILITY & DURABILITY CTION TECHNOLOGIES

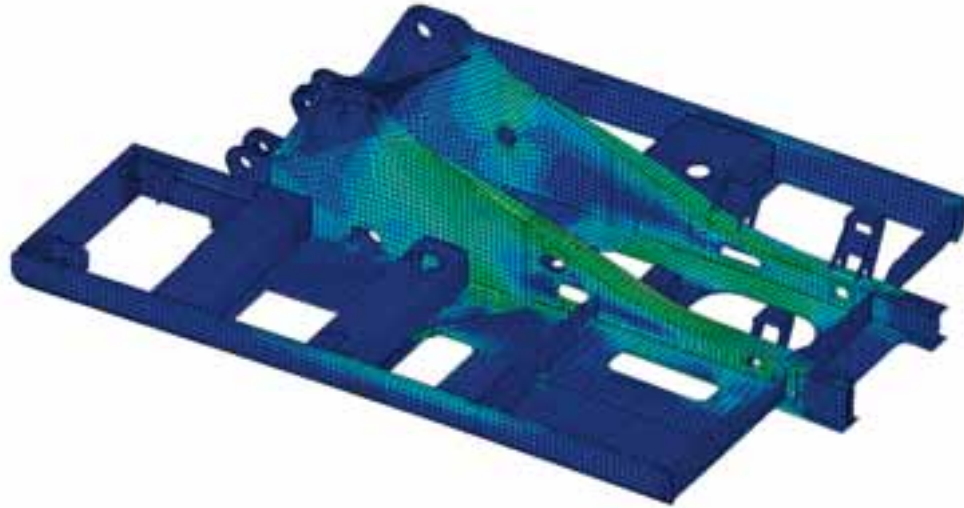

NEW LONG UNDERCARRIAGE FOR ALL VERSIONS

On all three versions (L, EL and LC) New Holland now offers different machine widths, whilst the length has been increased from 3373 to 3600 mm for enhanced durability, reliability, stability and performance, together with improved flotation in very wet ground and increased operator comfort.

TRACK GUIDE

A central mounted track guide is supplied as standard equipment on both track frames. If machine has to work and move in very uneven and rocky terrain, customers may choose the **optional 4 additional track guides** which are mounted, two per track frame, front and rear of the central ones. They contribute to keep the chains on rollers, same time protecting them, thus granting an **extended durability, maximum efficiency and safety**.



LENGTH OF L & EL VERSION + 9% = LC VERSION

E215B OPERATOR



NEW EVO CAB EVOLUTION IN COMFORT AND SAFETY

The interior of the cab has been completely re-designed to maximise operator comfort and to enable optimum operator performance. All switches and controls are now ergonomically positioned on the right side, easy to find and to reach. Enlarged side windows enhance the panoramic view.

The radio and the new, more powerful and effective automatic air-conditioning system are standard equipment, creating an agreeable working atmosphere regardless of external weather conditions. At the same time, new interior design and materials create an elegant feeling. Six silicon liquid filled viscous dampers minimise vibrations. The new, reinforced structure of the cab complies to ROPS and FOPS standards.

Together with the optional front guard it's effectively contributing to operator safety.



NEW A. E. P. MONITOR

The newly designed A.E.P. Monitor, features analogical gauges which provide one sight advice, regardless of the operating environment.

The digital Display Screen has been enlarged to further enhance visibility. Maintenance information is clearly displayed and the self-diagnostic function provides an early warning detection of malfunctions.

Details of any previous breakdown or malfunction are also stored.



NEW COMFORTABLE SEAT

New comfortable contoured seat which can be adjusted in all directions and back and forth, together with or independently of side consoles.

The armrests, integrated on side consoles, can be lifted/lowered into four different positions and inclined, enabling the operator to set the correct position for maximum convenience and comfort.



NEW ONE-HAND WINDSCREEN OPENING

One-touch lock release simplifies opening and closing the front window, while a new mechanism makes it lighter.

R SAFETY AND COMFORT



UNIQUE REAR CAMERA WITH “DEDICATED” IN CAB SCREEN

This is a very special option, enhancing active safety for both the operator and others on the job site. The **“dedicated screen”** is mounted inside the cab and is **unique to New Holland**. It allows the operator, whilst working, to simultaneously control both the job going on behind his machine and the machine's functional parameters, thanks to the **A.E.P.** display, which operates constantly. A really unique and outstanding feature in terms of **safety and comfort**.

E215B EASY MAIN

DESIGNED TO EFFECTIVELY CUT OPERATING COSTS

T CLEAN AND ACCESSIBLE LAYOUT

The new machine layout has been designed to make inspections, maintenance and servicing much easier and less time-consuming. The engine oil filter, the fuel filters and the water separator are remote mounted and easy to reach from ground level. Both the fuel filters and the water separator, which removes contaminants and water, have an important function for engine performance and durability. Cooling components (radiator, hydraulic oil cooler and intercooler) are now mounted in parallel, which means increased cooling efficiency for higher component reliability whilst being easier to check and clean.



The simplified layout of all vital components of the New Holland E215B under both the right and the left side panels makes maintenance much easier, less time consuming and less costly, and provides much better access for servicing. There is plenty of room in all compartments and most components are positioned in such a way to enable easy access from ground level. **An elegant and modern design added to state-of-the-art technology.**



T TOOL BOX

The tool box has been completely redesigned with a side-opening panel. It stores a new electric immersion type fuel pump, with automatic stop and alarm when the tank is full. The repositioning of the batteries (under the cooling components) and of the fuses (inside the cab) makes room in the compartment behind the cab for an additional wide and useful tool box.



T FUSES

The fuses are inside the cab, protected from dust and water as well as easy to reach and control.

MAINTENANCE & SERVICEABILITY

CENTRALISED GREASING

Maintenance procedures are also improved thanks to new grouped and centralised greasing points, which allow all boom wear points to be easily greased from ground level, after every 500 hours-long lasting intervals! On request, the E215B can be equipped with an “**Automatic Centralised Greasing System**” to supply all wear points of the machine with the right quantity of grease at the right time. A winning tool to **simultaneously reduce maintenance procedures and costs while improving machine reliability and durability.**



LONG LIFE HYDRAULIC OIL

The long-life hydraulic oil used by New Holland features excellent anti-emulsion characteristics as well as an optimised mix of anti-wear and anti-oxidants additives that **boost the service life to 5,000 hours**, reducing the number of oil changes necessary and resulting in an impressive **reduction in operation costs and a higher respect for the environment.**



INSIDE CAB MAINTENANCE

- Detachable two-piece floormat with handles for easy removal. A floor drain is located under the mat to facilitate inside cab cleaning.
- Airconditioning filter, positioned under the seat, can be easily removed without tools and from ground level, for easy cleaning.

E215B Serviceability Index (SAE 817-2)
**TOP
IN
CLASS**

SPECIFICATIONS



ENGINE TIER 3A

Net flywheel power (ISO 14396/ECE R120) 118 kW/158 hp
 Governed rpm 2000
 Make and model CNH 667TA/MEB
 Type diesel 4-stroke, direct injection, turbocharged and intercooler
 Displacement 6.7 l
 Number of cylinders 6
 Bore x stroke 104 x 132 mm
 Maximum torque at 1200 rpm 665 Nm

Remote engine oil filter for easy replacement

Electronic engine rpm control, dial type

Auto-Idling selector returns engine to minimum rpm when all controls are in neutral position

-25° C outside temperature start as standard equipment

The engine complies with 97/68/EC standards TIER 3A



ELECTRICAL SYSTEM

Voltage 24 V
 Alternator 70 A
 Starter motor 4 kW
 Standard maintenance-free batteries 2
 Capacity 100 Ah



HYDRAULIC SYSTEM

Higher capacity pumps, to supply higher flow at lower rpm;
Redesigned Main Control Valve, with added 2nd dipper spool and new Fail Safe Functions;

Bigger radius piping with SAE flange ports;

H.A.O.A. (Hydrotronic Active Operation Aid) to get the best hydraulic output according to operator/ application demand;

E.S.S.C. (Engine Speed Sensing Control) device, for total installed hydraulic power exploitation;

D.O.C. (Dipper Optimised Control) thanks to the 2nd dedicated spool in the Control Valve and to the Conflux system;

C.P.B. (Continuous Power Boost) to allow the operator to use extra power when and how long it is needed;

A.E.P. (Advanced Electronic Processor) interacting with the operator for selecting and monitoring main working parameters, maintenance programmes, self diagnosis and operating data storage thanks to the new monitor with a larger digital display and analogical gauges;

Two working modes:

- **S** = for normal digging operation;
- **H** = when maximum power is required;

Two Attachments modes:

- **A** = for attachments which require double pump flow;
- **B** = for attachments, such as breaker, featuring one way flow only.

Standard double pump flow device and Diverter Valve automatically actuated while selecting A;

Pipe pressure discharge push button to facilitate tooling changeover without piping oil leakage;

Super Fine hydraulic filter (8 micron) to grant perfect oil filtration, contributing to increase oil change interval

Main pumps:

Two variable delivery pumps with electronic delivery adjustment. Pumps automatically revert to zero delivery with controls in neutral.

Maximum delivery 2 x 220 l/min

Piloting circuit gear type pump

Maximum delivery 20 l/min

Maximum operating pressure:

Equipment/travel 34.3 MPa
 Swing 29.0 MPa
 Power Boost 37.8 MPa
 Hydraulic cylinders double effect
 - Lift (2) - bore x stroke 120 x 1345 mm
 - Penetration (1) - bore x stroke 135 x 1560 mm
 - Bucket (1) - bore x stroke 120 x 1080 mm
 - Positioning (only triple articulation) bore x stroke 145 x 990 mm

Independent hammer/positioning control



TRANSMISSION

Type hydrostatic, two-speed
 Travel motors 2, axial pistons type, double displacement
 Brakes automatic discs type
 Final drive oil bath, planetary reduction
 Gradeability (continuous) 70% (35°)
 Travel speeds:

low from 0 to 3.6 km/h
 high from 0 to 6.0 km/h

Drawbar pull 198 kN

Automatic Downshift device: to move travel motors to maximum displacement position with selector on "speed" position when greater traction is required.



SWING

Swing motor axial piston type
 Swing brake automatic discs type
 Final drive oil bath, planetary reduction
 Swing ring oil bath type
 Swing speed 12.7 rpm



CAB AND CONTROLS

Sound suppressed cab with modern design, integrated ROPS and standard FOPS, tinted safety glass, insertable front window, transparent cab roof. Standard automatic air conditioning and radio.

Controls piloted
 Two cross path pattern levers actuate all equipment movements and superstructure swing.

Two pedals with hand levers control all track movements, counter-rotation included.

A safety lever completely neutralizes the piloting circuit



UNDERCARRIAGE

X-frame undercarriage design

Reinforced track chain with sealed bushings.

	E215BL	E215BEL	E215BLC
Track rollers (each side)	8	8	8
Carrier rollers (each side)	2	2	2
Length of track on ground (mm)	3660	3660	3660
Gauge (mm)	2200	1990	2390
Shoes (mm)	600-700 800-900	500-600 700	600-700 800-900



CAPACITIES

litres
 Lube oil 21
 Coolant 26
 Fuel tank 320
 Hydraulic reservoir 230

E215B

ONE-PIECE BOOM

DIMENSIONS (mm) - OPERATING WEIGHT

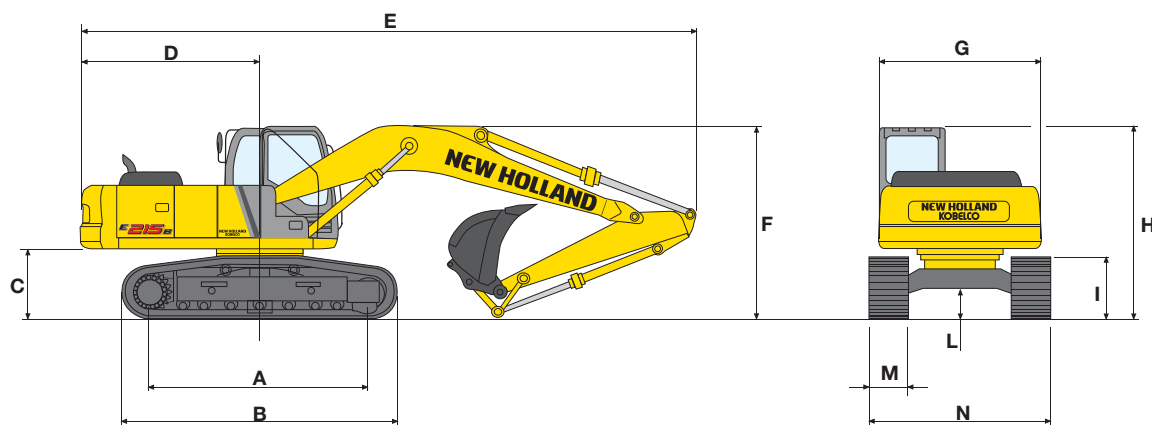

VERSIONS	A	B	C	D	E	F	G	H	I	L
E215BL	3660	4450	1035	2800	(1) 9580	(1) 3045	2500	3085	950	470
E215BEL	3660	4450	1035	2800	(1) 9580	(1) 3045	2500	3085	950	470
E215BLC	3660	4450	1035	2800	(1) 9580	(1) 3045	2500	3085	950	470

(1) 2400 mm dipperstick

		E215BL				E215BEL				E215BLC			
M - Shoe width	mm	600	700	800	900	500	600	700	600	700	800	900	
N - maximum width	mm	2800	2900	3000	3100	2490	2590	2690	2990	3090	3190	3290	
Operating weight	kg	21720	21990	22260	22530	21110	21380	21650	21950	22220	22490	22760	
Ground pressure	bar	0.50	0.44	0.39	0.35	0.59	0.50	0.43	0.51	0.44	0.39	0.35	

DIGGING PERFORMANCE

ONE-PIECE BOOM = 5650 mm

DIPPERSTICK	mm	2080	2400	2940	3500
A	mm	9185	9446	9929	10366
A'	mm	8991	9258	9750	10195
B	mm	5840	6160	6700	7260
B'	mm	5620	5954	6519	7082
C	mm	9440	9519	9733	9749
D	mm	6737	6793	7037	7149
E	mm	3679	3559	3544	3478

BREAKOUT FORCE:					
Bucket	daN	15500	15500	15500	15500
Dipperstick	daN	15200	13150	10900	9000

WITH POWER BOOST ON					
Bucket	daN	16900	16900	16900	16900
Dipperstick	daN	16500	14250	11800	9800

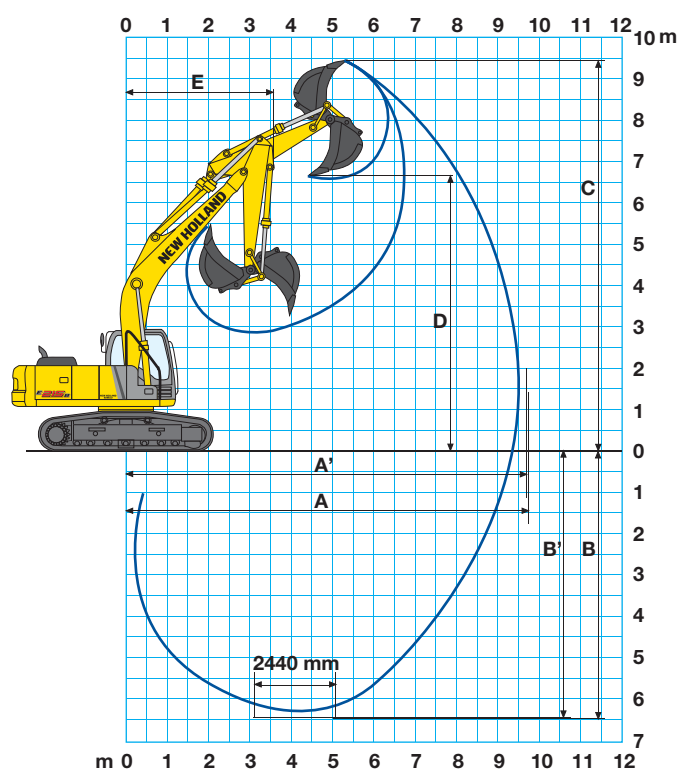

TRIPLE ARTICULATION DIMENSIONS (mm) - OPERATING WEIGHT

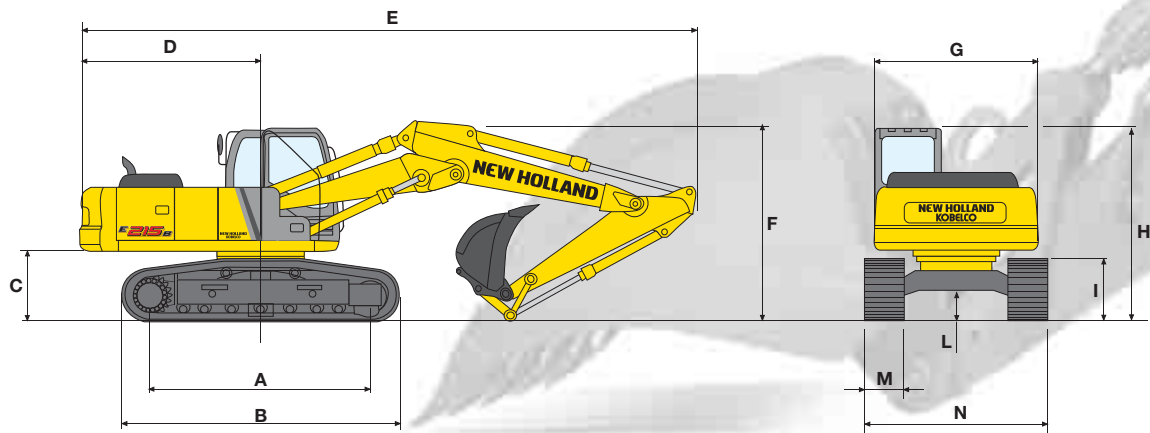

VERSIONS	A	B	C	D	E	F	G	H	I	L
E215BL	3660	4450	1035	2800	(1) 9665	(1) 3015	2500	3085	950	470
E215BEL	3660	4450	1035	2800	(1) 9665	(1) 3015	2500	3085	950	470
E215BLC	3660	4450	1035	2800	(1) 9665	(1) 3015	2500	3085	950	470

(1) 2400 mm dipperstick

		E215BL				E215BEL				E215BLC			
M - Shoe width	mm	600	700	800	900	500	600	700	600	700	800	900	
N - maximum width	mm	2800	2900	3000	3100	2490	2590	2690	2990	3090	3190	3290	
Operating weight	kg	22350	22660	22890	23160	21740	22010	22280	22500	22770	23040	23310	
Ground pressure	bar	0.56	0.45	0.40	0.39	0.61	0.51	0.44	0.52	0.45	0.40	0.36	

DIGGING PERFORMANCE

TRIPLE ARTICULATION
max extension= 5740 mm
min extension= 4560 mm

DIPPERSTICK	mm	2080	2400	2940	3500
A	mm	9322	9598	10098	10555
A'	mm	9131	9413	9922	10387
B	mm	5590	5891	6417	6932
B'	mm	5467	5775	6310	6832
C	mm	10682	10882	11280	11544
D	mm	7755	7952	8351	8632
E	mm	2929	2742	2524	2695

BREAKOUT FORCE:					
Bucket	daN	15500	15500	15500	15500
Dipperstick	daN	15200	13150	10900	9000

WITH POWER BOOST ON					
Bucket	daN	16900	16900	16900	16900
Dipperstick	daN	16500	14250	11800	9800

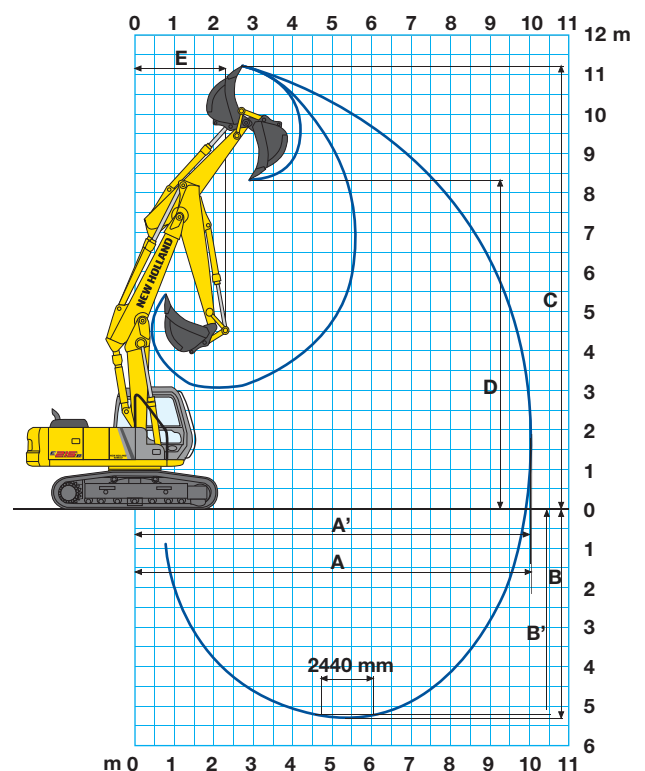

E215B

LIFTING CAPACITY

2080 mm DIPPERSTICK

VALUES ARE EXPRESSED IN TONNES

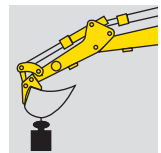

RADIUS OF LOAD

3.0 m		4.5 m		6.0 m		7.5 m		AT MAX. REACH		REACH m
FRONT	SIDE	FRONT	SIDE	FRONT	SIDE	FRONT	SIDE	FRONT	SIDE	

E215BEL ONE-PIECE BOOM

HEIGHT											
+6.0 m					5.8 *	4.6			5.6 *	3.8	6.7
+4.5 m			7.5 *	7.0 *	6.4 *	4.5			5.1	3.1	7.5
+3.0 m			9.5 *	6.5	7.3 *	4.3	5.1	3.0	4.6	2.8	7.9
+1.5 m			11.1 *	6.0	7.3	4.0	5.0	2.9	4.5	2.7	8.0
0			11.0	5.8	7.0	3.9	4.9	2.9	4.6	2.7	7.7
-1.5 m	14.7 *	10.7	10.7 *	5.8	6.9	3.8			5.1	3.0	7.2
-3.5 m	14.6 *	11.0	10.6 *	5.9	7.0	3.9			6.3	3.6	6.3
-4.5 m	11.0 *	10.3 *	7.8 *	6.2					6.9 *	5.6	4.8

E215BEL TRIPLE ARTICULATION

HEIGHT											
+6.0 m			6.7 *	6.3 *	5.3 *	4.6			4.5 *	3.7	6.8
+4.5 m	11.8 *	11.0 *	7.7 *	7.1	5.6 *	4.5	4.4 *	3.1	4.2 *	3.1	7.6
+3.0 m			9.7 *	6.5	6.3 *	4.2	4.5 *	3.0	4.1 *	2.7	8.0
+1.5 m			11.2	5.9	7.0 *	3.9	4.8 *	2.9	4.2 *	2.6	8.0
0			10.8	5.6	7.0	3.8	4.9 *	2.8	4.2 *	2.7	7.8
-1.5 m	12.1 *	10.2	10.0 *	5.6	6.9	3.7			4.5	2.8	7.3
-3.5 m			7.5	5.8	5.5	3.8			4.9	3.5	6.4
-4.5 m											

E215BL ONE-PIECE BOOM

HEIGHT											
+6.0 m					5.8 *	5.2			5.6 *	4.2	6.7
+4.5 m			7.5 *	7.0 *	6.4 *	5.0			5.3	3.5	7.5
+3.0 m			9.5 *	7.3	7.3 *	4.7	5.1	3.4	4.7	3.1	7.9
+1.5 m			11.1 *	6.8	7.3	4.5	5.0	3.3	4.5	3.0	8.0
0			11.1	6.5	7.2	4.3	4.9	3.2	4.6	3.0	7.7
-1.5 m		12.4	11.1	6.4	7.0	4.3			5.1	3.3	7.2
-3.0 m		12.6	10.6 *	6.6	7.2	4.3			6.3	4.1	6.3
-4.5 m	11.0 *	10.3 *	7.8 *	6.9					6.9	6.2	4.8

E215BL TRIPLE ARTICULATION

HEIGHT											
+6.0 m			6.7 *	6.3 *	5.3 *	4.9 *			4.5	4.1	6.8
+4.5 m	11.8 *	11.0 *	7.7 *	7.2 *	5.6 *	4.9	4.4 *	3.4	4.2 *	3.4	7.6
+3.0 m			9.7 *	7.2	6.3 *	4.7	4.5 *	3.3	4.1 *	3.0	8.0
+1.5 m			11.2	6.6	7.0 *	4.4	4.8 *	3.2	4.2 *	2.9	8.0
0			10.9	6.3	7.0	4.3	4.9 *	3.1	4.5	2.9	7.8
-1.5 m	12.1 *	11.3 *	10.0 *	6.3	7.0	4.2			5.0	3.2	7.3
-3.0 m			7.5 *	6.5	5.5 *	4.3			4.5 *	3.9	6.4
-4.5 m											

E215BLC ONE-PIECE BOOM

HEIGHT											
+6.0 m					5.5 *	5.5 *			5.5 *	4.7	6.7
+4.5 m			7.0 *	7.0 *	6.0 *	5.7			5.6 *	3.9	7.5
+3.0 m			8.9 *	8.3	6.8 *	5.5	5.8	3.8	5.4	3.5	7.9
+1.5 m			10.4 *	7.8	7.6 *	5.2	5.7	3.7	5.2	3.4	8.0
0			11.1 *	7.5	7.7	4.9	5.6	3.6	5.3	3.5	7.7
-1.5 m	13.8 *		10.0 *	7.4	7.7	4.9			5.9	3.8	7.2
-3.5 m	13.7 *		10.0 *	7.5	7.3	5.0			6.8 *	4.6	6.3
-4.5 m	10.3 *	10.3 *	7.3 *	7.3 *					6.8 *	6.7 *	4.8

E215BLC TRIPLE ARTICULATION

HEIGHT											
+6.0 m			6.3 *	6.3 *	4.9 *	4.9 *			4.4 *	4.4 *	6.8
+4.5 m	11.0 *	11.0 *	7.2 *	7.2 *	5.3 *	5.3 *	4.2 *	3.9	4.1 *	3.8	7.6
+3.0 m			9.1 *	7.2	5.9 *	5.4	4.3 *	3.8	4.0 *	3.4	8.6
+1.5 m			11.0 *	7.6	6.6 *	5.0	4.6 *	3.7	4.1 *	3.3	8.0
0			10.7 *	7.3	7.3 *	4.9	4.7 *	3.6	4.4 *	3.4	7.8
-1.5 m	11.3 *	11.3 *	9.3 *	7.3	7.1 *	4.8			5.2 *	3.7	7.3
-3.0 m			7.0 *	7.0 *	5.2 *	4.9			4.4 *	4.4 *	6.4
-4.5 m											

The table values refer to ISO 10567 for excavator equipped with bucket. The indicated load is no more than 87% of hydraulic system lift capacity or 75% of static tipping load. Values marked with an asterisk are limited by the hydraulic system.

LIFTING CAPACITY

2400 mm DIPPERSTICK

VALUES ARE EXPRESSED IN TONNES

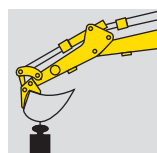

RADIUS OF LOAD

3.0 m		4.5 m		6.0 m		7.5 m		AT MAX. REACH		REACH m
FRONT	SIDE	FRONT	SIDE	FRONT	SIDE	FRONT	SIDE	FRONT	SIDE	

E215BEL ONE-PIECE BOOM

HEIGHT	3.0 m		4.5 m		6.0 m		7.5 m		AT MAX. REACH		REACH m
	FRONT	SIDE	FRONT	SIDE	FRONT	SIDE	FRONT	SIDE	FRONT	SIDE	
+6.0 m					5.4 *	4.7			4.1 *	3.4	7.2
+4.5 m					6.1 *	4.5	5.2	3.1	4.1 *	2.9	7.8
+3.0 m	14.5 *	12.2	8.9 *	6.6	6.9 *	4.3	5.1	3.0	4.3 *	2.6	8.2
+1.5 m			10.3 *	6.1	7.3	4.0	5.0	2.9	4.2	2.4	8.3
0	8.5 *	7.9 *	11.1	5.9	7.0	3.9	4.9	2.8	4.3	2.4	8.1
-1.5 m	13.5 *	10.8	11.0	5.8	6.9	3.8	4.9	2.8	4.6	2.7	7.6
-3.0 m	15.6 *	11.0	11.0 *	5.8	7.0	3.8			5.6	3.3	6.8
-4.5 m	12.2 *	11.3	8.7 *	6.0					6.7 *	4.7	5.4

E215BEL TRIPLE ARTICULATION

HEIGHT	3.0 m		4.5 m		6.0 m		7.5 m		AT MAX. REACH		REACH m
	FRONT	SIDE	FRONT	SIDE	FRONT	SIDE	FRONT	SIDE	FRONT	SIDE	
+6.0 m			6.4 *	6.0 *	5.1 *	4.6			3.9 *	3.3	7.6
+4.5 m	10.5 *	9.8 *	7.2 *	6.7 *	5.4 *	4.5	4.1 *	3.1	3.8 *	2.8	8.0
+3.0 m			9.0 *	6.6	5.9 *	4.3	4.3 *	3.0	3.8 *	2.4	8.3
+1.5 m			11.3	6.0	6.8 *	4.0	4.6 *	2.9	3.8 *	2.3	8.4
0	8.3 *	7.7 *	10.9	5.7	7.0	3.8	4.9	2.8	4.1 *	2.3	8.2
-1.5 m	13.1 *	10.3	10.6 *	5.6	6.9	3.7	4.8	2.7	4.5	2.7	7.7
-3.0 m			8.1	5.8	5.8	3.8			4.4 *	3.1	6.8
-4.5 m											

E215BL ONE-PIECE BOOM

HEIGHT	3.0 m		4.5 m		6.0 m		7.5 m		AT MAX. REACH		REACH m
	FRONT	SIDE	FRONT	SIDE	FRONT	SIDE	FRONT	SIDE	FRONT	SIDE	
+6.0 m					5.0 *	5.4 *	5.0 *		4.1 *	3.8	7.2
+4.5 m					5.7 *	6.1 *	5.0		4.1 *	3.2	7.8
+3.0 m	14.5 *	13.6 *	8.9 *	7.4	6.9 *	4.7	5.1	3.4	4.3 *	2.9	8.2
+1.5 m			10.8 *	6.9	7.3	4.5	5.0	3.3	4.2	2.8	8.3
0	8.5 *	7.9 *	11.2	6.6	7.2	4.3	4.9	3.2	4.3	2.8	8.1
-1.5 m	13.5 *	12.5	11.1	6.5	7.0	4.3	4.9	3.1	4.7	3.0	7.6
-3.0 m	15.6 *	12.7	11.0 *	6.6	7.0	4.3			5.7	3.7	6.8
-4.5 m	12.2 *	11.3	8.7 *	6.8					6.7 *	5.2	5.4

E215BL TRIPLE ARTICULATION

HEIGHT	3.0 m		4.5 m		6.0 m		7.5 m		AT MAX. REACH		REACH m
	FRONT	SIDE	FRONT	SIDE	FRONT	SIDE	FRONT	SIDE	FRONT	SIDE	
+6.0 m			6.4 *	6.0 *	5.1 *	4.7 *			3.9 *	3.7	7.6
+4.5 m	10.5 *	9.8 *	7.2 *	6.7 *	5.4 *	4.9	4.1 *	3.4	3.8 *	3.1	8.0
+3.0 m			9.0 *	7.3	5.9 *	4.7	4.3 *	3.3	3.8 *	2.8	8.3
+1.5 m			11.4	6.7	6.8 *	4.4	4.6 *	3.2	3.8 *	2.7	8.4
0	8.3 *	7.7 *	11.0	6.4	7.0	4.3	4.9 *	3.1	4.1 *	2.7	8.2
-1.5 m	13.1 *	10.3	10.6 *	6.4	7.0	4.2	4.9	3.1	4.5	3.0	7.7
-3.0 m			8.3 *	6.5	6.1	4.2			4.4 *	3.5	6.8
-4.5 m											

E215BLC ONE-PIECE BOOM

HEIGHT	3.0 m		4.5 m		6.0 m		7.5 m		AT MAX. REACH		REACH m
	FRONT	SIDE	FRONT	SIDE	FRONT	SIDE	FRONT	SIDE	FRONT	SIDE	
+6.0 m					6.0 *	5.7			5.1 *	4.9	6.8
+4.5 m			7.0 *	7.0 *	7.2 *	5.6	5.0 *	3.9	5.2 *	3.9	7.5
+3.0 m			8.8 *	8.3	7.4 *	5.5	5.7	3.8	5.3	3.6	7.9
+1.5 m			10.4 *	7.8	7.8	5.1	5.6	3.7	5.1	3.5	8.0
0	7.1 *	7.1 *	11.1 *	7.3	7.7	5.0	5.6	3.6	5.2	3.5	7.7
-1.5 m	13.8 *	13.5 *	10.0 *	7.2	7.6	4.9			5.9	3.8	7.2
-3.0 m	13.7 *	13.7 *	9.9 *	7.3	7.5 *	5.0			7.0 *	4.6	6.9
-4.5 m	10.3 *	10.5 *	7.3 *	7.3					6.8 *	6.7 *	4.7

E215BLC TRIPLE ARTICULATION

HEIGHT	3.0 m		4.5 m		6.0 m		7.5 m		AT MAX. REACH		REACH m
	FRONT	SIDE	FRONT	SIDE	FRONT	SIDE	FRONT	SIDE	FRONT	SIDE	
+6.0 m			6.0 *	6.0 *	4.7 *				3.8 *	3.8 *	7.6
+4.5 m	9.8 *	9.8 *	6.7 *	6.7 *	5.0 *	5.0	3.9 *	3.8	3.7 *	3.5	8.0
+3.0 m			8.4 *	8.3	5.6 *	5.4	4.1 *	3.8	3.7 *	3.2	8.3
+1.5 m			10.9 *	7.7	6.4 *	5.2	4.4 *	3.7	3.7 *	3.1	8.4
0	7.7 *	7.7 *	10.9 *	7.4	7.2 *	4.9	4.7 *	3.6	4.0 *	3.1	8.2
-1.5 m	12.3 *		9.9 *	7.3	7.4 *	4.8	4.8 *	3.5	4.5 *	3.4	7.7
-3.5 m			7.7 *	7.5	5.7	4.9			4.3 *	4.0	6.8
-4.5 m											

The table values refer to ISO 10567 for excavator equipped with bucket. The indicated load is no more than 87% of hydraulic system lift capacity or 75% of static tipping load. Values marked with an asterisk are limited by the hydraulic system.

LIFTING CAPACITY

2940 mm DIPPERSTICK

VALUES ARE EXPRESSED IN TONNES

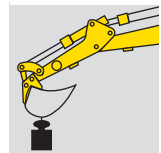

RADIUS OF LOAD

3.0 m		4.5 m		6.0 m		7.5 m		AT MAX. REACH		REACH m
FRONT	SIDE	FRONT	SIDE	FRONT	SIDE	FRONT	SIDE	FRONT	SIDE	

E215BEL ONE-PIECE BOOM

HEIGHT	3.0 m		4.5 m		6.0 m		7.5 m		AT MAX. REACH		REACH m
	FRONT	SIDE	FRONT	SIDE	FRONT	SIDE	FRONT	SIDE	FRONT	SIDE	
+6.0 m							3.5 *	3.2	2.7 *	2.7 *	7.7
+4.5 m					5.4 *	4.6	5.0 *	3.2	2.7 *	2.6	8.4
+3.0 m	12.2 *	11.4 *	8.0 *	6.8	6.4 *	4.3	5.1	3.0	2.9 *	2.2	8.8
+1.5 m	9.8 *	9.2 *	10.1 *	6.2	7.3	4.1	5.0	2.9	3.2 *	2.1	8.8
0	9.5 *	8.9 *	11.1	5.9	7.0	3.9	4.8	2.8	3.6 *	2.9	8.6
-1.5 m	12.7 *	10.6	10.9	5.7	6.9	3.7	4.8	2.7	4.2	2.3	8.2
-3.5 m	16.5 *	10.8	11.0	5.7	6.9	3.7			4.8	2.8	7.4
-4.5 m	13.8 *	11.1	9.7 *	5.9	6.8 *	3.9			6.4 *	4.1	6.1

E215BEL TRIPLE ARTICULATION

HEIGHT	3.0 m		4.5 m		6.0 m		7.5 m		AT MAX. REACH		REACH m
	FRONT	SIDE	FRONT	SIDE	FRONT	SIDE	FRONT	SIDE	FRONT	SIDE	
+6.0 m			5.7 *	5.4 *	4.7 *	4.4 *	3.7 *	3.2	2.6 *	2.6 *	7.8
+4.5 m	6.9 *	6.5 *	6.6 *	6.2 *	5.0 *	4.5	3.9 *	3.1	2.6 *	2.4	8.5
+3.0 m	14.7 *	12.5	8.1 *	6.7	5.6 *	4.3	4.1 *	3.0	2.6 *	2.2	8.8
+1.5 m	9.7 *	9.2 *	11.0 *	6.1	6.4 *	4.0	4.4 *	2.8	2.8 *	2.4	8.9
0	9.2 *	8.5 *	11.0	5.7	7.0	3.8	4.7 *	2.7	3.2 *	2.1	8.7
-1.5 m	12.3 *	10.2	10.9	5.6	6.9	3.7	4.8	2.7	3.8 *	2.2	8.3
-3.0 m	12.0 *	10.6	9.1 *	5.7	6.8 *	3.7			4.4 *	2.7	7.5
-4.5 m											

E215BL ONE-PIECE BOOM

HEIGHT	3.0 m		4.5 m		6.0 m		7.5 m		AT MAX. REACH		REACH m
	FRONT	SIDE	FRONT	SIDE	FRONT	SIDE	FRONT	SIDE	FRONT	SIDE	
+6.0 m							3.5 *	3.4 *	2.7 *	2.7 *	7.7
+4.5 m					5.4 *	5.0 *	5.0 *	3.5	2.7 *	2.7 *	8.4
+3.0 m	12.2 *	11.4 *	8.0 *	7.5 *	6.4 *	4.8	5.1	3.4	2.9 *	2.6	8.8
+1.5 m	9.8 *	9.2 *	10.1 *	6.9	7.4	4.5	5.0	3.3	3.2 *	2.4	8.8
0	9.5 *	8.9 *	11.2	6.6	7.2	4.3	4.9	3.1	3.6 *	2.4	8.6
-1.5 m	12.7 *	11.8 *	11.0	6.4	6.9	4.2	4.8	3.1	4.2	2.7	8.2
-3.5 m	16.5 *	12.4	11.0	6.4	6.9	4.2			4.9	3.2	7.4
-4.5 m	13.8 *	12.8	9.7 *	6.6	6.8 *	4.3			6.4 *	4.2	6.1

E215BL TRIPLE ARTICULATION

HEIGHT	3.0 m		4.5 m		6.0 m		7.5 m		AT MAX. REACH		REACH m
	FRONT	SIDE	FRONT	SIDE	FRONT	SIDE	FRONT	SIDE	FRONT	SIDE	
+6.0 m			5.7 *	5.4 *	4.7 *	4.4 *	3.7 *	3.5	2.6 *	2.6 *	7.8
+4.5 m	6.9 *	6.5 *	6.6 *	6.2 *	5.1 *	4.7 *	3.9 *	3.4	2.6 *	2.6 *	8.5
+3.0 m	14.7 *	13.8 *	8.1 *	7.5	5.6 *	4.7	4.1 *	3.3	2.6 *	2.4	8.8
+1.5 m	9.8 *	9.2 *	11.0 *	6.8	6.4 *	4.5	4.4 *	3.2	2.8 *	2.3	8.9
0	9.2 *	8.7 *	11.1	6.5	7.0	4.2	4.7 *	3.1	3.2 *	2.3	8.7
-1.5 m	12.3 *	11.5 *	11.0 *	6.4	6.9	4.1	4.8	3.0	3.8 *	2.6	8.3
-3.0 m	12.0 *	11.2 *	9.1 *	6.4	6.8 *	4.2			4.4 *	3.0	7.5
-4.5 m											

E215BLC ONE-PIECE BOOM

HEIGHT	3.0 m		4.5 m		6.0 m		7.5 m		AT MAX. REACH		REACH m
	FRONT	SIDE	FRONT	SIDE	FRONT	SIDE	FRONT	SIDE	FRONT	SIDE	
+6.0 m							3.4 *	3.4 *	2.7 *	2.6 *	7.7
+4.5 m					5.0 *	5.0 *	4.8 *	3.9	2.7 *	2.6 *	8.4
+3.0 m	11.4 *	11.4 *	7.5 *	7.5 *	6.0 *	5.5	5.3 *	3.8	2.9 *	2.8 *	8.8
+1.5 m	9.2 *	9.2 *	9.5 *	7.9	7.0 *	5.2	5.6	3.7	3.1 *	2.8	8.8
0	8.9 *	8.9 *	10.7 *	7.5	7.7	4.9	5.5	3.6	3.5 *	2.8	8.6
-1.5 m	11.8 *	11.8 *	11.1 *	7.4	7.6	4.8	5.5	3.5	4.3 *	3.0	8.2
-3.0 m	15.5 *	14.6	10.6 *	7.4	7.6	4.8			5.6	3.5	7.4
-4.5 m	12.9 *	12.8	9.1 *	7.6	6.4 *	4.9			6.3 *	4.7	6.1

E215BLC TRIPLE ARTICULATION

HEIGHT	3.0 m		4.5 m		6.0 m		7.5 m		AT MAX. REACH		REACH m
	FRONT	SIDE	FRONT	SIDE	FRONT	SIDE	FRONT	SIDE	FRONT	SIDE	
+6.0 m			5.4 *	5.4 *	4.4 *	4.4 *	3.6 *	3.6 *	2.6 *	2.5 *	7.8
+4.5 m	6.5 *	6.5 *	6.2 *	6.2 *	4.7 *	4.7 *	3.7 *	3.7 *	2.6 *	2.5 *	8.5
+3.0 m	13.8 *	13.8 *	7.6 *	7.6 *	5.3 *	5.3 *	3.9 *	3.8	2.6 *	2.5 *	8.8
+1.5 m	9.2 *	9.2 *	10.3 *	7.8	6.0 *	5.2	4.2 *	3.6	2.8 *	2.7 *	8.9
0	8.7 *	8.7 *	11.0 *	7.4	6.9 *	4.9	4.5 *	3.5	3.1 *	2.7	8.7
-1.5 m	11.5 *	11.5 *	10.3 *	7.3	7.5 *	4.8	4.7 *	3.5	3.7 *	2.9	8.3
-3.0 m	11.2 *	11.2 *	8.5 *	7.4	6.4 *	4.8			4.3 *	3.4	7.5
-4.5 m											

The table values refer to ISO 10567 for excavator equipped with bucket. The indicated load is no more than 87% of hydraulic system lift capacity or 75% of static tipping load. Values marked with an asterisk are limited by the hydraulic system.

LIFTING CAPACITY

3500 mm DIPPERSTICK

VALUES ARE EXPRESSED IN TONNES

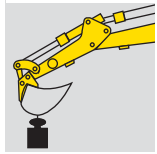

RADIUS OF LOAD

3.0 m		4.5 m		6.0 m		7.5 m		AT MAX. REACH		REACH m
FRONT	SIDE	FRONT	SIDE	FRONT	SIDE	FRONT	SIDE	FRONT	SIDE	

E215BEL ONE-PIECE BOOM

HEIGHT	3.0 m		4.5 m		6.0 m		7.5 m		AT MAX. REACH		REACH m
	FRONT	SIDE	FRONT	SIDE	FRONT	SIDE	FRONT	SIDE	FRONT	SIDE	
+6.0 m							3.9 *	3.2	2.5 *	2.4 *	8.2
+4.5 m							4.5 *	3.2	2.6 *	2.3	8.6
+3.0 m			7.0 *	6.6 *	5.7 *	4.3	5.0 *	3.0	2.7 *	2.1	9.1
+1.5 m	15.3 *	11.5	9.4 *	6.3	6.9 *	4.1	4.9	2.9	2.9 *	2.0	9.2
0	11.2 *	10.5 *	11.0 *	5.8	7.0	3.8	4.8	2.7	3.4 *	2.0	9.0
-1.5 m	12.9 *	10.5	12.9 *	5.6	6.8	3.9	4.7	2.7	3.8	2.1	8.6
-3.0 m	16.6 *	10.6	16.6 *	5.6	6.8	3.6	4.7	2.6	4.4	2.4	7.8
-4.5 m	15.1 *	10.8	15.1 *	5.7	6.8	3.7			5.7	3.4	6.6

E215BEL TRIPLE ARTICULATION

HEIGHT	3.0 m		4.5 m		6.0 m		7.5 m		AT MAX. REACH		REACH m
	FRONT	SIDE	FRONT	SIDE	FRONT	SIDE	FRONT	SIDE	FRONT	SIDE	
+6.0 m					4.3 *	4.0 *	3.5 *	3.2	2.4 *	2.3 *	8.3
+4.5 m			5.7 *	5.4 *	4.6 *	4.3 *	3.6 *	3.1	2.4 *	2.2	8.9
+3.0 m	11.4 *	10.7 *	7.2 *	6.7 *	5.2 *	4.3	3.9 *	3.0	2.5 *	2.0	9.2
+1.5 m	16.9 *	11.0	9.6 *	6.2	5.9 *	4.0	4.2 *	2.8	2.7 *	1.9	9.3
0	11.0 *	10.1	11.0	5.7	6.8 *	3.7	4.5 *	2.7	3.0 *	1.9	9.1
-1.5 m	12.5 *	10.0	10.8	5.5	6.8	3.6	4.7	2.6	3.6 *	2.0	8.7
-3.0 m	13.6 *	10.3	9.9 *	5.5	6.8	3.6	4.7	2.6	4.2	2.3	7.9
-4.5 m			7.2 *	5.7	5.2 *	3.7			4.0 *	2.9	6.7

E215BL ONE-PIECE BOOM

HEIGHT	3.0 m		4.5 m		6.0 m		7.5 m		AT MAX. REACH		REACH m
	FRONT	SIDE	FRONT	SIDE	FRONT	SIDE	FRONT	SIDE	FRONT	SIDE	
+6.0 m							3.9 *	3.6	2.5 *	2.4 *	8.2
+4.5 m							4.5 *	3.5	2.6 *	2.6 *	8.6
+3.0 m			7.0 *	6.6 *	5.7 *	4.8	5.0 *	3.4	2.7 *	2.3	9.1
+1.5 m	15.3 *	13.3	9.4 *	7.0	6.9 *	4.5	5.0	3.2	2.9 *	2.2	9.2
0	11.2 *	10.5 *	11.0 *	6.6	7.0	4.3	4.8	3.1	3.4 *	2.2	9.0
-1.5 m	12.9 *	12.1 *	12.9 *	6.4	6.9	4.1	4.7	3.0	3.8	2.4	8.6
-3.0 m	16.6 *	12.2	16.6 *	6.3	6.8	4.1	4.7	3.0	4.4	2.8	7.8
-4.5 m	15.1 *	12.5	15.1 *	6.4	6.9	4.2			5.7	3.6	6.6

E215BL TRIPLE ARTICULATION

HEIGHT	3.0 m		4.5 m		6.0 m		7.5 m		AT MAX. REACH		REACH m
	FRONT	SIDE	FRONT	SIDE	FRONT	SIDE	FRONT	SIDE	FRONT	SIDE	
+6.0 m					4.3 *	4.0 *	3.5 *	3.4 *	2.4 *	2.3 *	8.3
+4.5 m			5.7 *	5.4 *	4.6 *	4.3 *	3.6 *	3.4	2.4 *	2.3 *	8.9
+3.0 m	11.4 *	10.7 *	7.2 *	6.7 *	5.2 *	4.8 *	3.9 *	3.3	2.5 *	2.2	9.2
+1.5 m	16.9 *	12.6	9.6 *	6.9	5.9 *	4.5	4.2 *	3.2	2.7 *	2.1	9.3
0	11.0 *	10.3 *	11.1	6.4	6.8 *	4.2	4.5 *	3.0	3.0 *	2.1	9.1
-1.5 m	12.5 *	11.6	10.9	6.2	6.8	4.1	4.7 *	2.9	3.6 *	2.3	8.7
-3.0 m	13.6 *	11.9	9.9 *	6.2	6.8	4.0	4.7	2.9	4.2 *	2.7	7.9
-4.5 m			7.2 *	6.4	5.2 *	4.1			4.0 *	3.2	6.7

E215BLC ONE-PIECE BOOM

HEIGHT	3.0 m		4.5 m		6.0 m		7.5 m		AT MAX. REACH		REACH m
	FRONT	SIDE	FRONT	SIDE	FRONT	SIDE	FRONT	SIDE	FRONT	SIDE	
+6.0 m							3.7 *	3.7 *	2.5 *	2.4 *	8.2
+4.5 m							4.3 *	4.0	2.6 *	2.6 *	8.6
+3.0 m			6.6 *	6.6 *	5.4 *	5.4 *	4.8 *	3.8	2.7 *	2.7 *	9.1
+1.5 m	14.3 *	14.3 *	8.8 *	8.0	6.5 *	5.2	5.4 *	3.7	2.9 *	2.7	9.2
0	10.5 *	10.5 *	10.3 *	7.5	7.4 *	4.9	5.5	3.5	3.3 *	2.7	9.0
-1.5 m	12.1 *	12.1 *	12.1 *	7.3	7.5	4.7	5.4	3.4	4.0 *	2.8	8.6
-3.0 m	15.6 *	14.3	15.6 *	7.3	7.5	4.7	5.4	3.4	5.0	3.3	7.8
-4.5 m	14.1 *	14.1 *	14.1 *	7.4	7.0 *	4.8			6.1 *	4.2	6.6

E215BLC TRIPLE ARTICULATION

HEIGHT	3.0 m		4.5 m		6.0 m		7.5 m		AT MAX. REACH		REACH m
	FRONT	SIDE	FRONT	SIDE	FRONT	SIDE	FRONT	SIDE	FRONT	SIDE	
+6.0 m					4.0 *	4.0 *	3.4 *	3.4 *	2.4 *	2.3 *	8.3
+4.5 m			5.4 *	5.4 *	4.3 *	4.3 *	3.5 *	3.5 *	2.4 *	2.3 *	8.9
+3.0 m	10.7 *	10.7 *	6.7 *	6.7 *	4.8 *	4.8 *	3.7 *	3.7 *	2.5 *	2.4 *	9.2
+1.5 m	15.9 *	14.7 *	9.0 *	7.9	5.6 *	5.2	4.0 *	3.6	2.7 *	2.6	9.3
0	10.3 *	10.3 *	10.8 *	7.4	6.4 *	4.8	4.3 *	3.5	3.0 *	2.6	9.1
-1.5 m	11.7 *	11.7 *	10.5 *	7.2	7.2 *	4.7	4.5 *	3.4	3.5 *	2.7	8.7
-3.0 m	12.8 *	12.8 *	9.3 *	7.2	6.8 *	4.7	4.6 *	3.4	4.1 *	3.1	7.9
-4.5 m			6.7 *	6.7 *	4.8 *	4.7			3.9 *	3.7	6.7

The table values refer to ISO 10567 for excavator equipped with bucket. The indicated load is no more than 87% of hydraulic system lift capacity or 75% of static tipping load. Values marked with an asterisk are limited by the hydraulic system.

NEW HOLLAND. THE POWER OF A GLOBAL BRAND

New Holland is a global brand with a key position in the Construction Equipment business. It supplies a complete range of 13 product lines and 80 basic models split into Compact line and Heavy line. It operates in all the main markets, such as Europe, North and Latin America, Africa, Asia and Middle East with the same technology and under the same logo and brand. It manufactures durable, safe and productive machines aimed at supporting customers in developing their own business. Dealers are company partners. They play an important role to support the brand in their territories through intense professional relationship with Customers. New Holland is reinforced by its global alliance with Kobelco: world leader in hydraulic excavator technology.



AT YOUR OWN DEALERSHIP

The information contained in this brochure is intended to be a general nature only. The NEW HOLLAND KOBELCO CONSTRUCTION MACHINERY S.p.A. company may at any time and from time to time, for technical or other necessary reasons, modify any of the details or specifications of the product described in this brochure. Illustrations do not necessarily show products in standard conditions. The dimensions, weights and capacities shown herein, as well as any conversion data used, are approximate only and are subject to variations within normal manufacturing techniques.

Published by NEW HOLLAND KOBELCO CONSTRUCTION MACHINERY S.p.A.
Printed in Italy - MediaCross Firenze - Cod. IR1311NCGB - Printed 07/11

Printed on recycled paper
CoC-FSC 000010 CQ Mixed sources



ELEMENTAL
CHLORINE
FREE
GUARANTEED

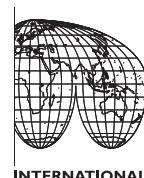

BUILT AROUND YOU

www.newholland.com