

CASE

HYDRAULIC EXCAVATOR **CX240B**



Engine Horsepower	132 kW - 177 hp
Operating weight (max)	24.5 t
Bucket capacity	0.47 m ³ to 1.43 m ³

P R O F E S S I O N A L P A R T N E R

DIGGING FORCE

Advanced hydraulic system has three working modes offering higher breakout forces, improved swing speeds and greater swing torque, resulting in faster cycle times and 5% increase in productivity. Power boost function is automatically engaged in Auto mode.

Fuel efficient common rail engine meets Tier III emission regulations with reduced fuel consumption and increase in output. Electronic management of speed and power offering lower fuel consumption and productivity benefits. **Lower fuel costs. Higher machine output.**



ROBUST DESIGN

Rugged appearance of improved cab and upper structure contribute to high operator satisfaction. Compact four cylinder Tier III engine uses technology from much larger Case machines, to reduce ownership costs and boost productivity. Exhaust gas recirculation ensures minimum environmental impact.

Cab design provides more space and comfort, reducing operator fatigue over the working day. Advanced engine control system eases operation, with three-mode hydraulic control matching the machine to the application.

Designed to work. Built to perform.

DURABILITY BUILT IN

Redesigned upperstructure to match increased hydraulic performance, ensures legendary Case durability and reliability. Boom and dipper feature forged brackets and reduced tolerances for increased component life and reduced downtime. Resin side shims on boom and dipper contribute to lower wear and longer service intervals. High performance undercarriage components designed to perform in arduous conditions. New synthetic hydraulic filter reduces system contamination, cutting service costs and boosting machine longevity.

Reduced ownership cost. Increased uptime.

PROFITABILITY BONUS

Lower fuel consumption and a 20% increase in fuel tank capacity, result in up to two day work period between refills. High flow electric refuelling pump with auto stop feature as standard. Extended Maintenance System bushes provide 1,000 hour greasing intervals on majority of pins. Green oil drain plugs ease maintenance and provide environmental benefits. Ground access to all filters and best in class service times ensure maximum uptime and reduced ownership and operating costs.

Ease of maintenance. Built to keep working.

OPERATOR COMFORT

Improved cab structure offers more leg and foot space, with glass surface increase contributing to spacious impression for the operator. Ergonomic layout, intuitive controls, short comfortable joysticks and a seat that lays flat ensures optimum comfort for all operators. Viscous fluid cab mountings and lower internal noise levels contribute to a reduction in stress and fatigue, boosting machine performance. Four position consoles with return to preset on left hand console will suit operators of all sizes.

Maximum comfort. Operator satisfaction.



SAFETY FIRST

New cab offers larger glass area for improved all round visibility, including single window on right hand side for unobstructed view. Frame structure has three times the structural rigidity of previous model, reducing noise and vibration for the operator. Simple control console with ergonomic design makes it easier to choose the correct operating mode, increasing efficiency and reducing fuel consumption.

Improved visibility. Reduced operator fatigue.

ENGINE



Low speed four cylinder common rail engine exceeds Tier III emissions standards and ready for Tier IV. Strong engine block and ladder frame construction, with virtually the same weight as previous six cylinder engine, provide extended durability and with low rev cooling fan contribute to 5% lower noise levels. Fuel cooler results in improvement in engine fuel consumption, while exhaust gas recirculation (EGR) reduces gaseous emissions. Radiators and coolers mounted side by side for improved cooling, while large diameter low speed fan contributes to lower noise levels. Auto and one-touch idle speed control for greater operator control.

HYDRAULICS



Hydraulic pump torque variable control system, maintains optimum engine rpm during heavy load work. Control rapidly reacts to demand, resulting in fuel saving. Hydraulic system uses improved piston pumps with tighter tolerances, reducing system losses and contributing with the new swing relief system into important fuel saving. Revised hose burst control valves mounted behind the main lift cylinders, for maximum safety. Synthetic fibre Super Fine full flow hydraulic filter offers high contamination catching performance, with no need for additional filter when using hydraulic breakers.

RH CONSOLE, ENGINE THROTTLE



Easy to read console has centralised switch layout for ease of use and luminosity sensor to ensure that graphics can be read in any light conditions. Advanced engine throttle control determines working mode selection, with Power Boost always on in Auto mode. Fully adjustable consoles house short lever joysticks, that are comfortable and improve machine controllability. Machine versatility further improved, as up to 10 auxiliary hydraulic flow settings are programmed into the CX240B's memory. This allows up to 10 attachments to be used with no manual adjustment to hydraulic circuit. Operator can change between hydraulic attachment settings from within the cab.

OPERATOR'S CAB

Improved cab has reduced width pillars and 60% more glass, including single piece window on right hand side, for great improvement in all round visibility. Structure is 30% stronger, which with viscous fluid cab mounts results in lower noise and vibration, reducing operator fatigue. Four positions for consoles and return to preset on left hand console. Standard air conditioning with nine outlet louvres, along with longer seat slides, a fully reclining seat and more foot space, ensure that operators of any size can get comfortable. Cup holders, clock, mobile phone holder, built-in coolbox and numerous storage compartments for ease of day to day living.



MAINTENANCE



All filters can be accessed from ground level in centralised position, reducing regular service time. Fuel tank has drain cock and removable maintenance plate, making it easier to clean out in case of contamination. High flow refuelling pump, twice as fast as previous model, has auto stop function to make refilling faster; further reducing downtime. Green engine oil drainer helps reduce environmental impact. Centralised electrics positioned within the cab, behind the operator's seat, to ensure cleanliness and dry operating conditions.

UNDERCARRIAGE



Track components are designed for extended durability. Case sprockets are heat treated for longer service life. Durability of track guides and track links has been further improved, with new M shaped seals and increased pin hardness extending operating hours and boosting the Case reputation for robust durable design. Track rollers have revised shape and design for less wear, with an improved O-ring design extending service life.

IMPROVED PIN AND BUSHING LIFE



EMS chrome plated pins with brass bushing

Extended Maintenance Bushings (EMS) fitted as standard on all CXB machines (only on machines above the CX330 previously). EMS bushings provide 1,000 hour greasing intervals on all but bucket linkage, which retains 250 hour intervals. Anti-friction shims at boom foot and head limit friction and noise in operation and cut free play, increasing durability and reliability and reducing ownership costs.

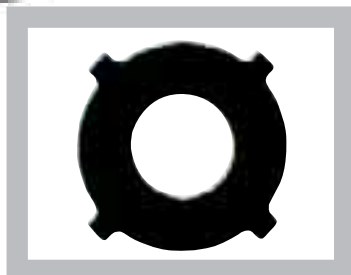

Anti-friction shims



ATTACHMENTS/BUCKETS

CX240B customers can choose from a variety of main booms and dipper arms to suit different applications, all of which are constructed of heavy duty steel box section with internal baffles to increase torsional rigidity. Deep groove welding ensures that the booms and arms can withstand the stress of high breakout forces, heavy lifting and attachments such as hydraulic breakers, compactors, demolition shears and crushers.

With a different choice of booms and dipper sticks, along with a range of buckets from 0.47m³ - 1.43 m³, there is a configuration to meet the requirements of every customer's job site.





SPECIFICATIONS

ENGINE

Latest generation engine, meeting European requirements for "Low exhaust emissions" Tier III in accordance with directive 97/ 68/EC

Make _____ ISUZU
 Type _____ AH-4HK1X
 Common rail, turbo, intercooler, fuel coolerGR (Exhaust Gas Recirculator) _____ Yes
 Direct injection _____ Electronically controlled
 Number of cylinders _____ 4
 Bore - Stroke _____ 115 x 125 mm
 Cubic capacity _____ 5193 cc
 Horsepower EEC80/1269 ___ 132 kW/177 hp @ 2000 rpm
 Maximum Torque _____ 636 Nm @ 1500 rpm

HYDRAULIC SYSTEM

Max output _____ 2 x 234 l/min @ 2000 rpm
 2 axial piston, variable flow pumps _____ Yes
 Attachment/Power Boost _____ 343/368 bar
 Upperstructure swing _____ 289 bar
 Travel _____ 343 bar
 Oil filtration _____ 6 micron
 Type of oil filter _____ Synthetic fiber Super fine High catch

SWING

Max upperstructure swing speed _____ 10.7 rpm
 Swing torque _____ 7490 daN

TRAVEL

The travel circuit is equipped with axial piston, variable flow motors

Max travel speed _____ 5.5 km/h
 Low travel speed _____ 3.5 km/h
 Speed change is controlled from the instrument panel
 Automatic downshifting _____ yes
 Gradeability _____ 70% (35°)
 Tractive force _____ 2013 daN

ELECTRICAL SYSTEM

Circuit _____ 24V
 Batteries _____ 2 X 12V - 92 A/h
 Circuit equipped with water-proof connectors _____ yes
 Alternator _____ 24 V - 50 Amp

UNDERCARRIAGE

Upper rollers _____ 2
 Lower rollers _____ 9
 Number of track pads _____ 51
 Type of shoes _____ Triple grouser
 Track pad width Standard LC/NLC _____ 600 mm
 Track guard _____ Front and 1 central

CIRCUIT AND COMPONENT CAPACITIES

Fuel tank _____ 410 l
 Hydraulic reservoir LC/NLC _____ 147 l
 Hydraulic system _____ 250 l
 Travel reduction gear (per side) _____ 4.5 l
 Swing reduction gear _____ 9.7 l
 Engine (including filter change) _____ 23.1 l
 Engine cooling system _____ 25.2 l

BUCKETS

GENERAL PURPOSE

SAE capacity	l	475	640	810	940	1060	1180	1300	1430
Width	mm	600	750	900	1000	1100	1200	1300	1400
Weight	kg	525	560	660	715	725	765	805	840

HEAVY DUTY

SAE capacity	l	1060	1180	1300	1430
Width	mm	1100	1200	1300	1400
Weight	kg	820	865	905	950

Other types of bucket on application

CX240B

GENERAL DIMENSIONS

WITH 5.85 m STANDARD MONOBOOM

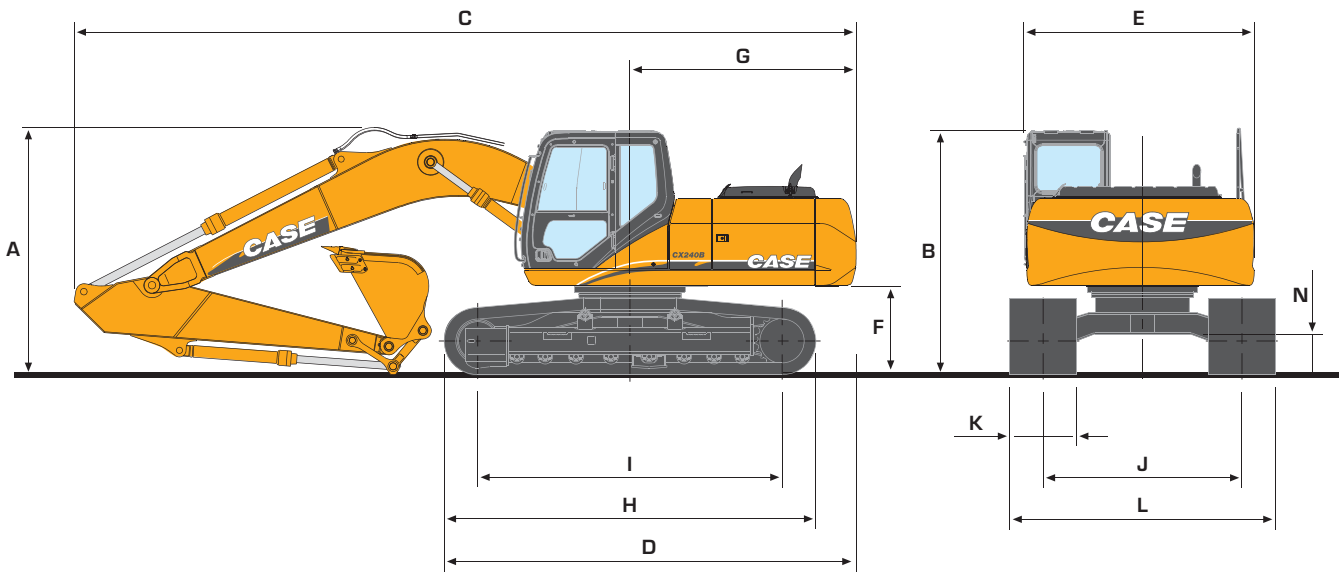

		CX240B LC Mono			CX240B NLC Mono		
		2.50 m	3.00 m	3.52 m	2.50 m	3.00 m	3.52m
DIPPER LENGTH							
A Overall height (with attachment)	m	3.31	3.15	3.31	3.31	3.15	3.31
B Height (cab/handrail)	m	3.00/3.02	3.00/3.02	3.00/3.02	3.00/3.02	3.00/3.02	3.00/3.02
C Overall length (with attachment)	m	9.98	9.93	9.91	9.98	9.93	9.91
D Overall length (without attachment)	m	5.27	5.27	5.27	5.27	5.27	5.27
E Width of upperstructure	m	2.77	2.77	2.77	2.77	2.77	2.77
F Upperstructure ground clearance	m	1.10	1.10	1.10	1.10	1.10	1.10
G Swing radius (rear end)	m	2.94	2.94	2.94	2.94	2.94	2.94
H Track overall length	m	4.65	4.65	4.65	4.65	4.65	4.65
I Centre idler to centre sprocket	m	3.84	3.84	3.84	3.84	3.84	3.84
J Track gauge	m	2.59	2.59	2.59	2.39	2.39	2.39
K Track shoe width standard	mm	600	600	600	600	600	600
L Track overall width - 600mm shoes	m	3.19	3.19	3.19	2.99	2.99	2.99
- 700mm shoes	m	3.29	3.29	3.29	-	-	-
- 800mm shoes	m	3.39	3.39	3.39	-	-	-
N Ground clearance	m	0.46	0.46	0.46	0.46	0.46	0.46

WEIGHT AND GROUND PRESSURE

With 5.85 m standard monoboomb 3.00 m dipper - 810 kg, 1.1 m³ bucket, operator and full fuel tank

	WEIGHT (kg)		GROUND PRESSURE (bar)	
	LC	NLC	LC	NLC
shoes 600mm steel	24 500	24 500	0.48	0.48
shoes 700mm steel	24 800	-	0.42	-
shoes 800mm steel	25 100	-	0.37	-

MONOBOOMB

PERFORMANCE DATA

WITH 5.85 m STANDARD MONOBOOM - 3.00 m DIPPER

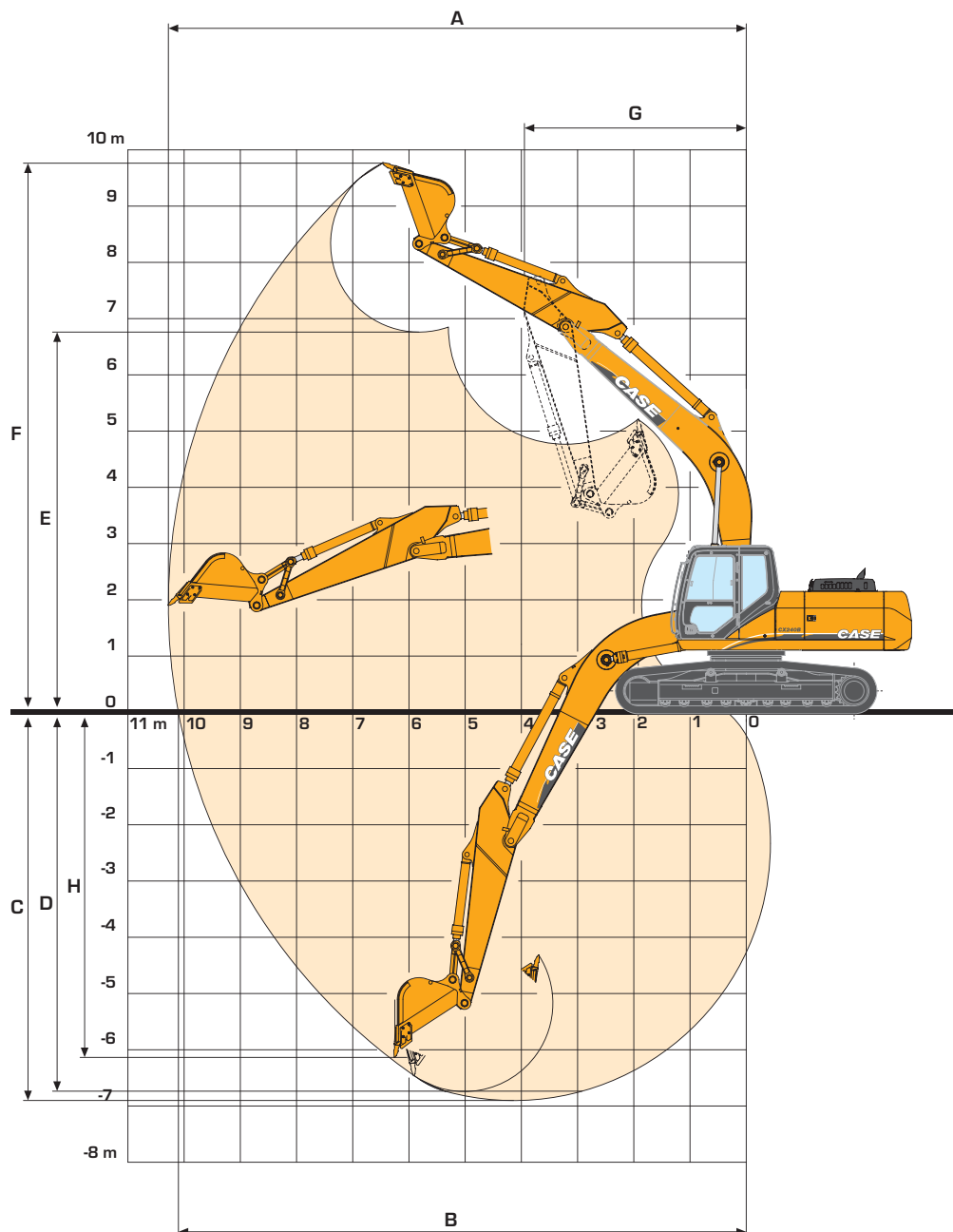

DIPPER LENGTH

		2.50 m	3.00 m	3.52 m	
A	Maximum digging reach	m	9.82	10.28	10.79
B	Maximum digging reach at ground level	m	9.63	10.10	10.62
C	Maximum digging depth	m	6.40	6.90	7.42
D	Digging depth - 2.44 m level bottom	m	6.21	6.74	7.27
E	Max dump height	m	6.55	6.76	7.06
F	Overall reach height	m	9.56	9.76	10.07
G	Minimum swing radius - attachment	m	3.98	3.95	3.95
H	Vertical straight wall dig depth	m	5.70	6.14	6.68
	Digging force				
	- w/o Power Boost	daN	14 100	12 000	10 700
	- with Power Boost	daN	15 100	12 900	11 500
	Breakout force				
	- w/o Power Boost	daN	16 200	16 200	16 200
	- with Power Boost	daN	17 400	17 400	17 400

CX240B

LIFTING CAPACITY

WITH 5.85 m STANDARD MONOBOOM

Values are expressed in kilos

Front 360°	REACH										
	3.0 m	4.5 m	6 m	7.5 m	9.0 m	At max reach		m			

LC with 3.52 m dipper, 600 mm shoes and bucket of 1.0 m³ - 790 kg

7.5 m												2576*	2576*	7.41
6.0 m							4353*	4317				2447*	2447*	8.34
4.5 m							5158*	4169				2442*	2442*	8.93
3.0 m			8204*	8204*	6576*	5771	5750*	3955	3522*	2831		2540*	2540*	9.24
1.5 m	11 484*	11 484*	10 604*	8395	7810*	5351	5850	3730	4138*	2719		2751*	2562	9.30
0 m	10 114*	10 114*	12 270*	7814	8091	5021	5644	3542	3753*	2627		3116*	2575	9.11
-1.5 m	12 677*	12 677*	12 931	7549	7875	4830	5521	3429				3742*	2751	8.65
-3 m	16 904*	15 468	12 705*	7512	7820	4782	5511	3421				4922*	3180	7.89
-4.5 m	16 495*	15 838	11 388*	7667	7947	4893						6673	4158	6.72
-6 m	11 758*	11 758*	8095*	8095*								7389*	7263	4.83

LC with 3.00 m dipper, 600 mm shoes and bucket of 1.1 m³ - 806 kg

7.5 m												3182*	3182*	6.72
6.0 m							3906*	3906*				3039*	3039*	7.74
4.5 m					6046*	6046*	5630*	4127				3062*	3062*	8.37
3.0 m	14 604*	14 604*	9149*	9037	7142*	5690	6064	3931				3221*	3018	8.70
1.5 m	8696*	8696*	11 366*	8238	8283*	5301	5841	3727				3538*	2873	8.76
0 m	9984*	9984*	12 711*	7766	8078	5017	5666	3567				4087*	2900	8.56
-1.5 m	13 767*	13 767*	12 970	7591	7916	4873	5580	3489				4995	3131	8.08
-3 m	18 165*	15 702	12 466*	7623	7918	4875						5913	3703	7.25
-4.5 m	15 129*	15 129*	10 676*	7851								7719*	5130	5.95

LC with 2.50 m dipper, 600 mm shoes and bucket of 1.3 m³ - 868 kg

6.0 m												4446*	4466*	7.20
4.5 m					6592*	5992	6063*	4072				4521*	3716	7.88
3.0 m			10 003*	8832	7638*	5615	6026	3899				4806*	3318	8.23
1.5 m			12 012*	8113	8350	5261	5830	3720				4959	3159	8.29
0 m	9259*	9259*	13 017*	7748	8077	5020	5688	3590				5074	3207	8.08
-1.5 m	14 867*	14 867*	13 026*	7655	7967	4923	5646	3552				5575	3510	7.56
-3 m	17 127*	15 976	12 095*	7750	8029	4977						6810	4273	6.68
-4.5 m	13 537*	13 537*	9742*	8061								8200*	6402	5.23

NLC with 3.52 m dipper, 600 mm shoes and bucket of 1.0 m³ - 790 kg

7.5 m												2576*	2576*	7.41
6.0 m							4353*	3943				2447*	2447*	8.34
4.5 m							5158*	3797				2442*	2442*	8.93
3.0 m			8204*	8204*	6576*	5248	5750*	3587	3522*	2550		2540*	2417	9.24
1.5 m	11 484*	11 484*	10 604*	7547	7810*	4836	5832	3365	4138*	2438		2751*	2294	9.30
0 m	10 114*	10 114*	12 270*	6984	8066	4514	5626	3181	3753*	2348		3116*	2301	9.11
-1.5 m	12 677*	12 677*	12 892	6726	7850	4327	5502	3070				3742*	2457	8.65
-3 m	16 904*	13 467	12 705*	6690	7796	4279	5493	3061				4922*	2846	7.89
-4.5 m	16 495*	13 816	11 388*	6841	7922	4389						6651	3733	6.72
-6 m	11 758*	11 758*	8095*	7257								7389*	6524	4.83

NLC with 3.00 m dipper, 600 mm shoes and bucket of 1.1 m³ - 806 kg

7.5 m												3182*	3182*	6.72
6.0 m							3906*	3882				3039*	3039*	7.74
4.5 m					6046*	5559	5630*	3757				3062*	3045	8.37
3.0 m	14 604*	14 604*	9149*	8170	7142*	5170	6046	3564				3221*	2723	8.70
1.5 m	8696*	8696*	11 366*	7396	8283*	4790	5823	3364				3538*	2583	8.76
0 m	9984*	9984*	12 711*	6939	8053	4511	5648	3207				4087*	2601	8.56
-1.5 m	13 767*	13 496	12 931	6770	7891	4370	5562	3130				4979	2807	8.08
-3 m	18 165*	13 691	12 466*	6800	7893	4372						5894	3325	7.25
-4.5 m	15 129*	14 122	10 676*	7021								7719*	4616	5.95

NLC with 2.50 m dipper, 600 mm shoes and bucket of 1.3 m³ - 868 kg

6.0 m												4446*	4105	7.20
4.5 m					6592*	5466	6063*	3703				4521*	3374	7.88
3.0 m			10 003*	7973	7638*	5097	6008	3534				4806*	2999	8.23
1.5 m			12 012*	7277	8325	4750	5812	3358				4943	2846	8.29
0 m	9259*	9259*	13 017*	6922	8053	4515	5669	3230				5057	2883	8.08
-1.5 m	14 867*	13 696	13 000	6832	7942	4420	5627	3192				5557	3154	7.56
-3 m	17 127*	13 951	12 095*	6925	8004	4473						6789	3845	6.68
-4.5 m	13 537*	13 537*	9742*	7226								8200*	5763	5.23

Machine in Auto mode

Lift capacities are taken in accordance with SAE J1097/ISO 10567/DIN 15019-2

Lift capacities shown in kg do not exceed 75% of the tipping load or 87% of the hydraulic lift capacity

Capacities that are marked with an asterisk (*) are hydraulic limited

If the machine is equipped with a quick coupler, subtract the weight of the quick coupler from the load shown in the table to calculate the real lift capacity

GENERAL DIMENSIONS

WITH 10.30 m LONG REACH BOOM

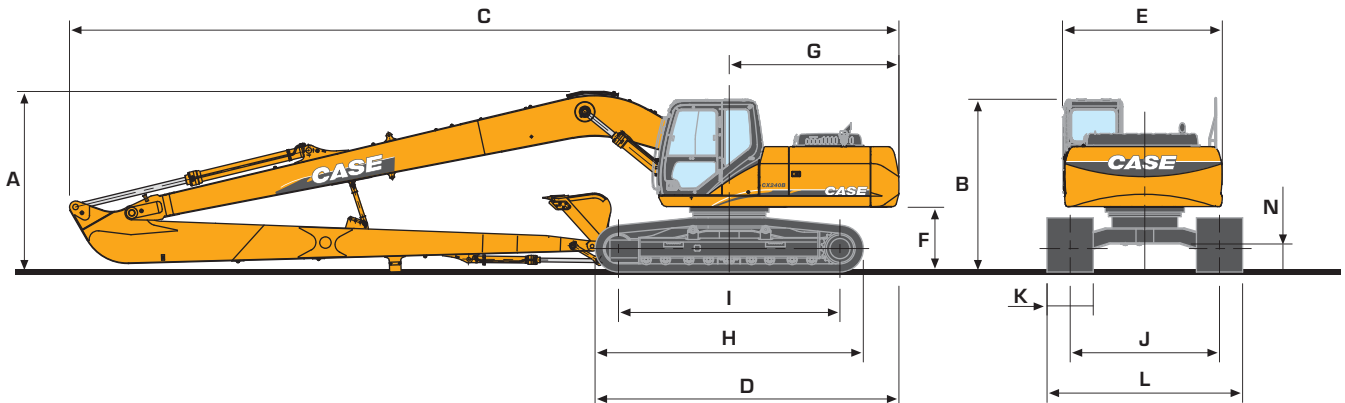

CX240B LR

DIPPER LENGTH

8.00 m

A	Overall height (with attachment)	m 3.13
B	Height (cab/handrail)	m 3.00/3.02
C	Overall length (with attachment)	m 14.38
D	Overall length (without attachment)	m 5.27
E	Width of upperstructure	m 2.77
F	Upperstructure ground clearance	m 1.10
G	Swing radius (rear end)	m 2.94
H	Track overall length	m 4.65
I	Centre idler to centre sprocket	m 3.84
J	Track gauge	m 2.59
K	Track shoe width standard	mm 800
L	Track overall width - 800 mm shoes	m 3.39
N	Ground clearance	m 0.46

WEIGHT AND GROUND PRESSURE

With 10.30 m long reach
boom 8.00 m dipper
338 kg, 0.37m³ bucket
operator and full fuel tank

WEIGHT (kg)	GROUND PRESSURE (bar)
-------------	-----------------------

shoes 800 mm steel	28 000	0.42
--------------------	--------	------

BUCKETS

GENERAL PURPOSE

	I	370	570
SAE capacity			
Width	mm	600	910

DITCH

	I	570	670
SAE capacity			
Width	mm	1520	1680

PERFORMANCE DATA

WITH 10.30 m LONG REACH BOOM - 8.00 m DIPPER

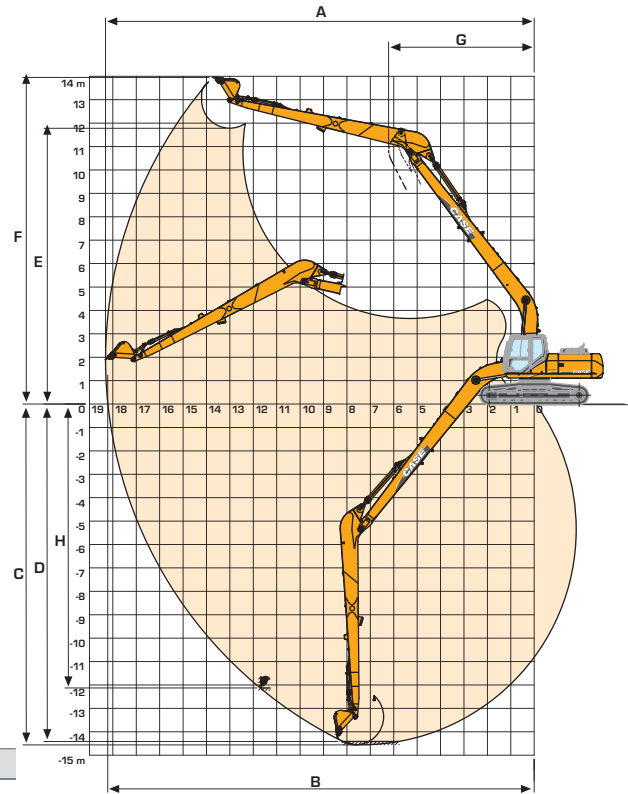

DIPPER LENGTH

8.00 m

A	Maximum digging reach	m	18.32
B	Maximum digging reach at ground level	m	18.22
C	Maximum digging depth	m	14.56
D	Digging depth - 2.92 m level bottom	m	14.41
E	Max dump height	m	11.78
F	Overall reach height	m	13.95
G	Minimum swing radius - attachment	m	6.22
H	Vertical straight wall dig depth	m	12.19
	Digging force	daN	4400
	Breakout force	daN	7700

LIFTING CAPACITY

WITH 10.30 m LONG REACH BOOM

Values are expressed in kilos

Front 360°	REACH											m
	3.0 m	4.5 m	6.0 m	7.5 m	9.0 m	10.5 m	12.0 m	13.5 m	15 m	16.5 m	At max reach	

LR with 8.00 m dipper, 800 mm shoes and bucket of 0.37m³ - 338 kg

	3.0 m	4.5 m	6.0 m	7.5 m	9.0 m	10.5 m	12.0 m	13.5 m	15 m	16.5 m	At max reach												
10.5 m											1509*	1509*	13.78										
9.0 m											1474*	1474*	14.77										
7.5 m									1681*	1681*	1463*	1463*	15.55										
6.0 m								1723*	1723*	1721*	1721*	1474*	1413	16.16									
4.5 m								1834*	1834*	1794*	1665	1609*	1288	1505*	1264	16.60							
3.0 m								2086*	2086*	1974*	1974*	1893*	1581	1843*	1234	1555*	1150	16.91					
1.5 m						2874*	2874*	2541*	2541*	2306*	2306*	2134*	1877	2009*	1487	1922*	1171	1627*	1065	17.07			
0 m	2102*	2102*	7167*	7167*	5246*	5246*	4042*	4042*	3327*	3327*	2860*	2758	2537*	2184	2305*	1742	2134*	1391	1915	1105	1724*	1004	17.10
-1.5 m	1685*	1685*	3914*	3914*	6179*	5576	4662*	4133	3758*	3187	3171*	2514	2766*	2008	2475*	1615	2210	1299	1850	1042	1745	967	17.00
-3.0 m	1929*	1929*	3407*	3407*	6591*	5032	5172*	3740	4134*	2903	3451*	2306	2977*	1855	2540	1502	2126	1219	1794	988	1743	953	16.76
-4.5 m	2336*	2336*	3518*	3518*	5881*	4708	5548*	3470	4433*	2691	3584	2143	2936	1732	2445	1411	2059	1154			1774	963	16.39
-6.0 m	2815*	2815*	3880*	3880*	5907*	4543	5636	3307	4327	2550	3463	2029	2843	1643	2377	1346	2015	1112			1846	1003	15.86
-7.5 m	3347*	3347*	4388*	4388*	6306*	4491	5553	3232	4246	2474	3393	1963	2790	1592	2341	1312	2000	1098			1969	1079	15.16
-9.0 m	3932*	3932*	5017*	5017*	6976*	4525	5550	3229	4228	2457	3374	1945	2778	1582	2343	1314					2166	1206	14.27
-10.5 m	4579*	4579*	5771*	5771*	7172*	4634	5617	3290	4270	2496	3407	1977	2815	1616							2479	1413	13.15
-12.0 m	5297*	5297*	6680*	6680*	8145*	4817	5308*	3416	4348*	2594	3500	2064									2999	1761	11.74
-13.5 m	6090*	6090*	7497*	7497*	8145*	5087	4670*	3620	3801*	2766											3352*	2417	9.90
					4507*	4507*															3686*	3686*	7.32

Machine in Auto mode Lift capacities are taken in accordance with SAE J1097/ISO 10567/DIN 15019-2 Lift capacities shown in kg do not exceed 75% of the tipping load or 87% of the hydraulic lift capacity Capacities that are marked with an asterisk (*) are hydraulic limited. If the machine is equipped with a quick coupler, subtract the weight of the quick coupler from the load shown in the table to calculate the real lift capacity

CX240B

STANDARD EQUIPMENT & OPTIONS

STANDARD EQUIPMENT

Engine control

- Common rail engine Tier III European Standards
- Electronic control of the injection system
- Automatic engine pre-heating
- Automatic/manual engine return to idle
- Exhaust Gas Recirculator
- Emergency stop
- Electrical refuel pump with automatic stop
- Fuel filter with water separator

Hydraulic control

- Auto/Heavy/Super Power working modes
- Pump torque variable control
- Automatic Power boost control
- Swing brake control
- High performance "Super Fine" synthetic fiber hydraulic filter (high contamination catch)
- Hydraulic safety valves on boom and dipper
- 2 travel speeds with auto down shifting

Operator environment

- High visibility cab with safety glass
- Adjustable and retractable armrest console with position memory
- Safety lever
- Self adjusting Air conditioning and heating system
- Cup holder
- High visibility side monitor display with automatic brightness
- Messages (function, temperature, safety, ...) on the display
- Integrated diagnostic system
- Working modes (Auto/Heavy/Super Power) combined with engine throttle
- Anti-theft device
- Hourmeter
- Selectable auxiliary hydraulic flow pre-settings
- RH front console with clock and cell phone holder
- High capacity shock absorbers on cab with 4 points fluid mountings
- Rain deflector
- Windscreen with lockable opening
- Windscreen washer and wiper
- Removable lower front windscreen with storage location in cab
- Glass cab roof window and sliding sun shade
- ISO control pattern low effort & short joysticks
- Adjustable sun visor

- Washable cab floor mat
- Rear view mirror and safety mirrors
- Storage compartments
- Integrated cool box
- 12V and 24V DC accessory sockets
- Hammer/Shear change selected from the cab
- Fore & aft adjustment of the whole seat & console

Electrical system

- Water proof connectors
- Double horn
- 2 working light on the cab
- Working light on the fuel tank
- Working light on the boom

Equipment

- EMS (Extended Maintenance System) pins and bushings as Standard (1000 hours lubrication interval for all, except buckets pins at 250 hours)
- Low friction resin side shims on boom and dipper
- Sealed and lubricated tracks
- Track guides (1 guide & front)
- Large tool box
- Pre-disposal for the optional cab protection

Operator seat

- Fully adjustable low frequency air suspension seat including double acting hydraulic damper
- Adjustable head rest
- Adjustable seat back angle with fully flat seat reclining
- Adjustable arm rest
- Adjustable lombar position
- Height/fore & aft adjustment
- Safety belt

OPTIONS

- Bucket/clamshell hydraulic circuit
- Hammer hydraulic circuit
- Hammer/shear hydraulic circuit
- Additional track guides (3 guides & front instead of 1 guide & front)
- Track width (600mm - 700mm - 800mm depending on the version)
- Windscreen protection
- Cab protection
- GPS (Global Positioning System) by satellite
- Centralized greasing system automatically actuated by an electrical grease pump

Standard and optional equipment shown can vary by country.

Worldwide Case Construction Equipment Contact Information

EUROPE/AFRICA/MIDDLE EAST:
Centre D'affaires EGB
5, Avenue Georges Bataille - BP 40401
60671 Le Plessis-Belleville - FRANCE

NORTH AMERICA/MEXICO:
700 State Street
Racine, WI 53404 U.S.A.

LATIN AMERICA:
Av. General David Sarnoff 2237
32210 - 900 Contagem - MG
Belo Horizonte BRAZIL

ASIA PACIFIC:
Unit 1 - 1 Foundation Place - Prospect
New South Wales - 2148 AUSTRALIA

CHINA:
No. 29, Industrial Premises, No. 376,
De Bao Road, Waigaoqiao Ftz, Pudong,
SHANGHAI, 200131, P.R.C.

NOTE: Standard and optional fittings can vary according to the demands and specific regulations of each country. The illustrations may include optional rather than standard fittings - consult your Case dealer. Furthermore, CNH reserves the right to modify machine specifications without incurring any obligation relating to such changes.

Case Construction Equipment

CNH UK Ltd.
Armstrong House
The Finningley Estate
Hayfield Lane
Doncaster
DN9 3XA
Fax +44 (0)1302 802126

www.casece.com

CASE



Conforms to directive 98/37/CE