

5130B

Hydraulic Shovel/
Backhoe

CAT[®]



Available in Front Shovel and Backhoe configuration, the new Caterpillar[®] 5130B is primarily matched to the Cat[®] 777D truck, but can also be teamed with the 773D or 775D and other trucks in the 65 to 100 ton size class. This makes for efficient loading and hauling systems for mining, quarrying and heavy construction applications.

Operating weights (approximate)

Front Shovel (FS)	181 000 kg	399,000 lb
Backhoe (ME)	182 000 kg	401,000 lb

Bucket capacities

Front Shovel (FS)	9.0 to 11.0 m ³	11.0 to 14.5 yd ³
Backhoe (ME)	8.5 to 18.3 m ³	10.5 to 24.0 yd ³

Cat 3508B Engine (Gross)	641 kW	860 hp
(Flywheel power)	597 kW	800 hp

5130B Hydraulic Shovel/Backhoe

Top performance and rugged durability combine to maximize your productivity.

Hydraulics

Powerful Cat hydraulics provide high break-out and crowd force to maximize bucket loads. The Cat Proportional Priority Pressure Compensating (PPPC) system allows smooth, efficient operation. **pg. 4 - 5**

Power Train

The 5130B is powered by a single Cat 3508B engine with a high displacement and conservative hp ratings for lower maintenance and operating costs. The 777D truck has field proven the 3508B engine design in the most demanding mining applications. **pg. 6**

Structures

Extensive use of castings in high-stress areas and box section design provide a rugged, durable machine. Use of one-piece floating pins in main front structure joints helps reduce wear and increase strength. Thermal stress relief of front structure components eliminates residual stresses. **pg. 7**



Undercarriage

Cat designed, excavator-type undercarriage is stable, durable and maintenance free. **pg. 8**

Operator's Station

Roomy, quiet cab has excellent sightlines to the work area to help keep operator fatigue low and production up throughout the entire shift. **pg. 9**

Vital Information Management System

The latest in total machine monitoring, (VIMS) monitors vital machine functions. It helps reduce downtime by keeping the operator informed of current operating conditions and allowing service personnel access to logged data and machine faults. **pg. 10**

Buckets and Ground Engaging Tools

The 5130B's aggressive curved-floor bucket design, efficient linkage geometry and high crowd and breakout forces provide superior bucket fill factors. A wide selection of front shovel buckets, backhoe buckets and ground engaging tools allows precise machine to application match. **pg. 11**

Modular Design

The eight modules that make up the 5130B are easily shipped and assembled. Components are located with serviceability and maintenance in mind. **pg. 12**



Hydraulics System

Caterpillar hydraulics deliver the power and control needed to keep material moving at high volume.

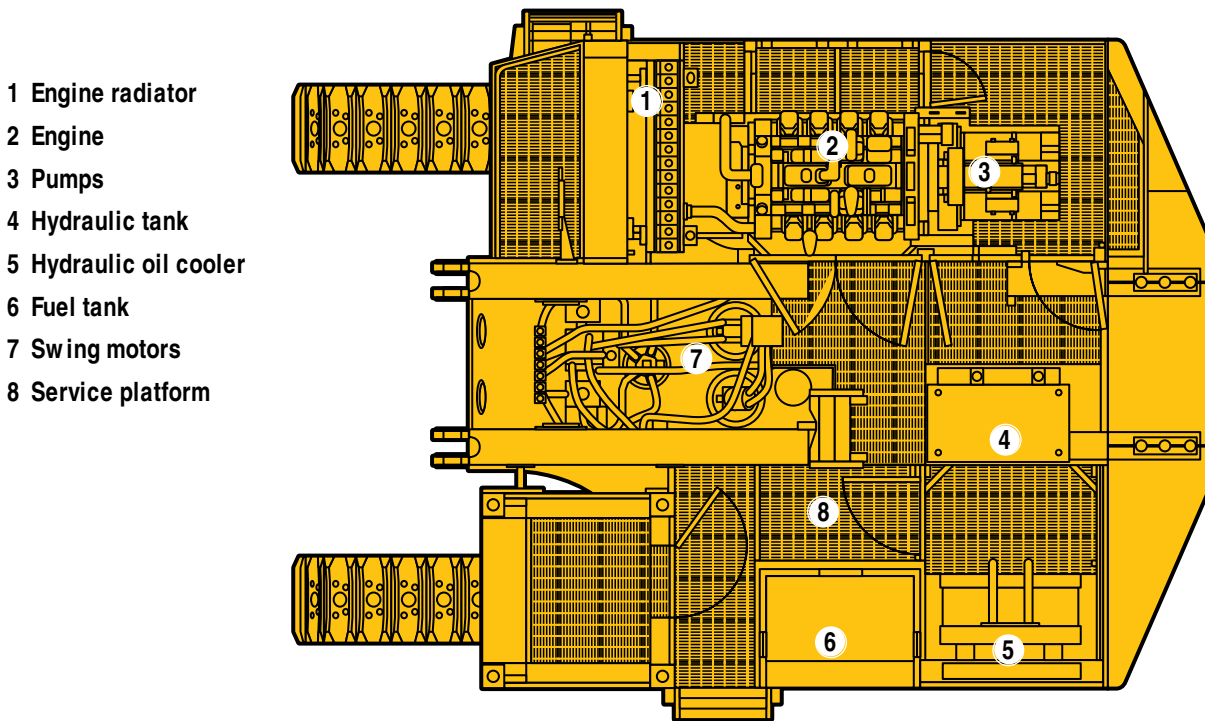

High breakout and crowd forces.

The 5130B Front Shovel and Backhoe provide maximum forces at the bucket cutting edge for improved material penetration and bucket fill factors.

- The front shovel has a breakout force of 715 kN (161,000 lbs) and a crowd force of 770 kN (173,000 lbs).
- The mass excavator arrangement has a breakout force of 672 kN (151,100 lbs) and a stick force of 624 kN (140,300 lbs), the highest in its size class.

Four variable-displacement, piston pumps

act together to power the front structure and travel systems. The swing function is powered by its own variable-displacement piston pump.

- Main pumps are each rated at a conservative 375 lpm (99 gpm) for optimum service life.
- The swing pump is rated at 450 lpm (119 gpm).
- Other, smaller pumps power the cooling fan drives, pump drive cooler, pilot system, automatic track tensioning system, and A/C system.
- All pumps are serviced through Cat dealers.
- A bulkhead separates the engine and pump compartments.

The modular design

of the 5130B provides unique advantages in hydraulic system design and serviceability.

- The longitudinal mounting of the 3508B engine and the low placement of the hydraulic pumps eliminate the need for a pressurized hydraulic tank.
- Walk-around, lighted access to all hydraulic system components allows easy serviceability and quick daily maintenance checks.

Hydraulic system filtration is provided by 200 micron screens in the pump discharge lines and 10 micron filters in the return lines and case drain line.

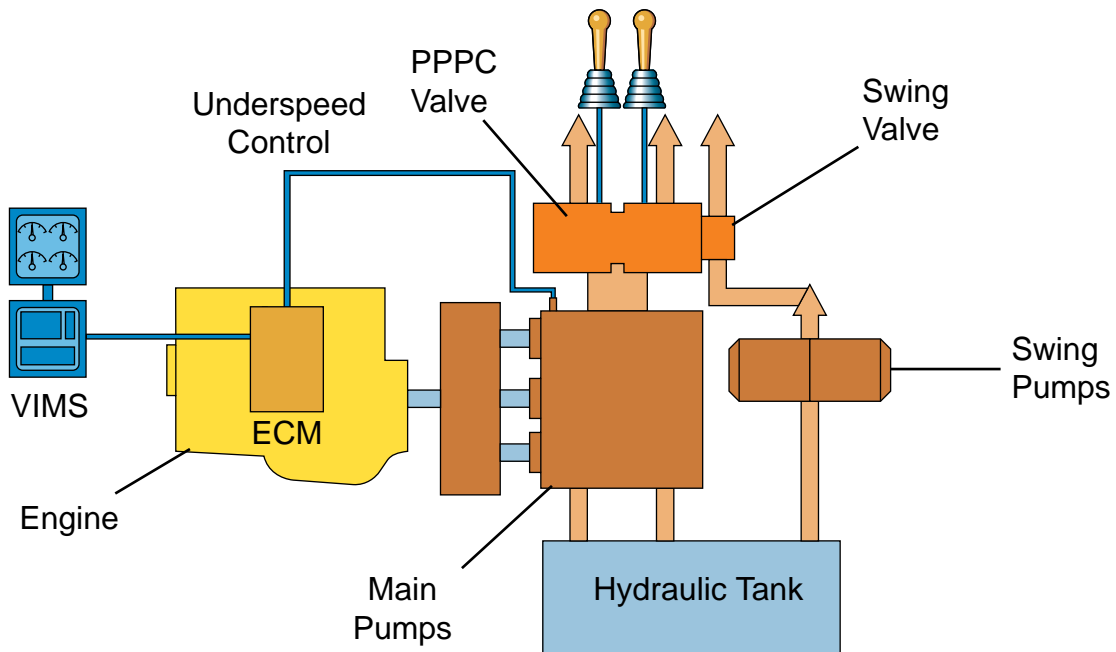

Exclusive Caterpillar Proportional Priority Pressure Compensating (PPPC) valves are used in both the front structure and travel systems.

- Valve system only circulates fluid when called for by the operator. There is no unneeded fluid circulation. This provides increased fuel efficiency and reduced heat in the hydraulic system.
- Automatic flow proportioning adjusts pump output to the hydraulic circuits based on the flow requirements of the task at hand. When flow is required by more than one function at a time (such as boom up and stick out), the valves determine the flow required for each function and have pumps supply that amount. This feature allows smooth, precise, multi-function operation.

The swing circuit is controlled by an open-center valve to assure quick, full-powered response.

Electronically controlled pumps.

A Caterpillar designed microprocessor regulates hydraulic pump output. When hydraulic demand goes beyond a prescribed threshold, the load sensing control destrokes the pumps to prevent excessive engine lugging.

- Eliminates the need to maintain a constant, costly, reserve of engine power to prevent excessive engine lugging.
- Also allows hydraulic pumps to use full engine power for precise front structure or function response.

Hydraulic system cooling is provided by a single, conventional core radiator dedicated to the hydraulic circuit.

- The variable-speed fan is temperature controlled for greater fuel efficiency.
- Extra-large cooling capacity allows operation in ambient temperatures of up to 50°C (122°F).

Large-bore cylinders ensure efficient load handling.

Cat's XT hydraulic hose is exceptionally strong and flexible. Reusable couplings prolong hose assembly life.

S•O•S sampling valves are conveniently located on the return rail on the right side of the hydraulic tank.

Cat 3508B Engine

The single engine of the 5130B provides an edge in operating costs and fuel efficiency.

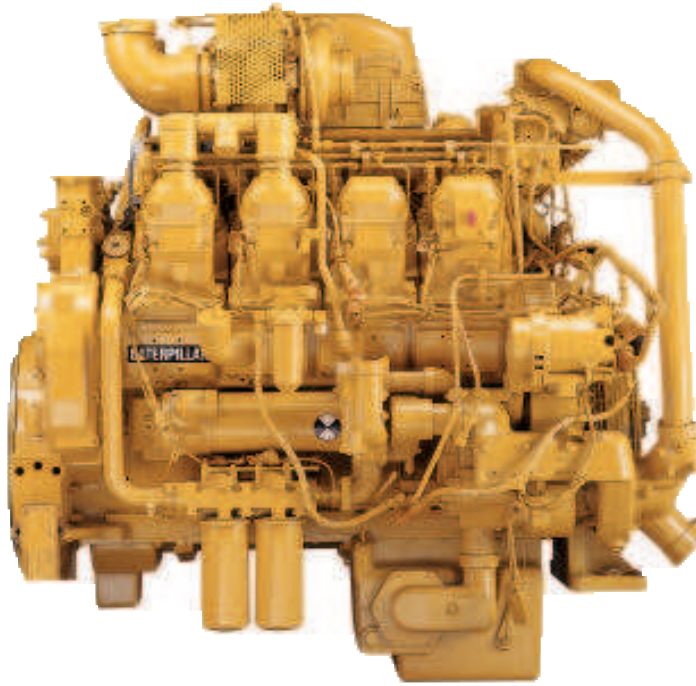

The Caterpillar electronic control system provides superior integration of the engine and other machine systems. All systems are designed specifically for use in mining applications.

The 3508B Electronic Unit Injection (EUI) engine features:

- Excellent reliability with the latest in protection programs.
- Protection during cold weather starts.
- Excellent fuel efficiency.
- Continuous monitoring of critical engine functions.
- Diagnostic data is accessible with a single, electronic service tool.
- Automatic altitude compensation above 3050 m (10,000 ft).
- Integrated ether injection.
- Cold cylinder cutout.

Automatic Engine Speed Control (AESC) reduces fuel consumption and noise by reducing the engine speed from 1750 to 1350 rpm if the hydraulic controls are not actuated for four seconds.

Engine cooling system reduces fuel consumption using a hydraulic driven variable-speed fan. Fan operates at a minimum speed of 400 rpm until increased temperatures actuate a solenoid and valve to increase fan speed as needed.

Increased time between oil changes, up 100 percent, from 250 hours to 500 hours between changes.

Cold weather starting can be improved with EUI's cold weather starting mode. This mode retards engine timing until the engine is warmed to the correct temperature.

High displacement, low rpm rating and conservative hp ratings mean longer service hours with less downtime for maintenance and repair.

Two-piece piston design with aluminum skirt and steel crown pivot at the wrist pin provides added flexibility for reduced piston scuffing.

S•O•S sampling valve located near oil filter base speeds sampling.

Structures

The 5130B structural components are the backbone of the machines durability.

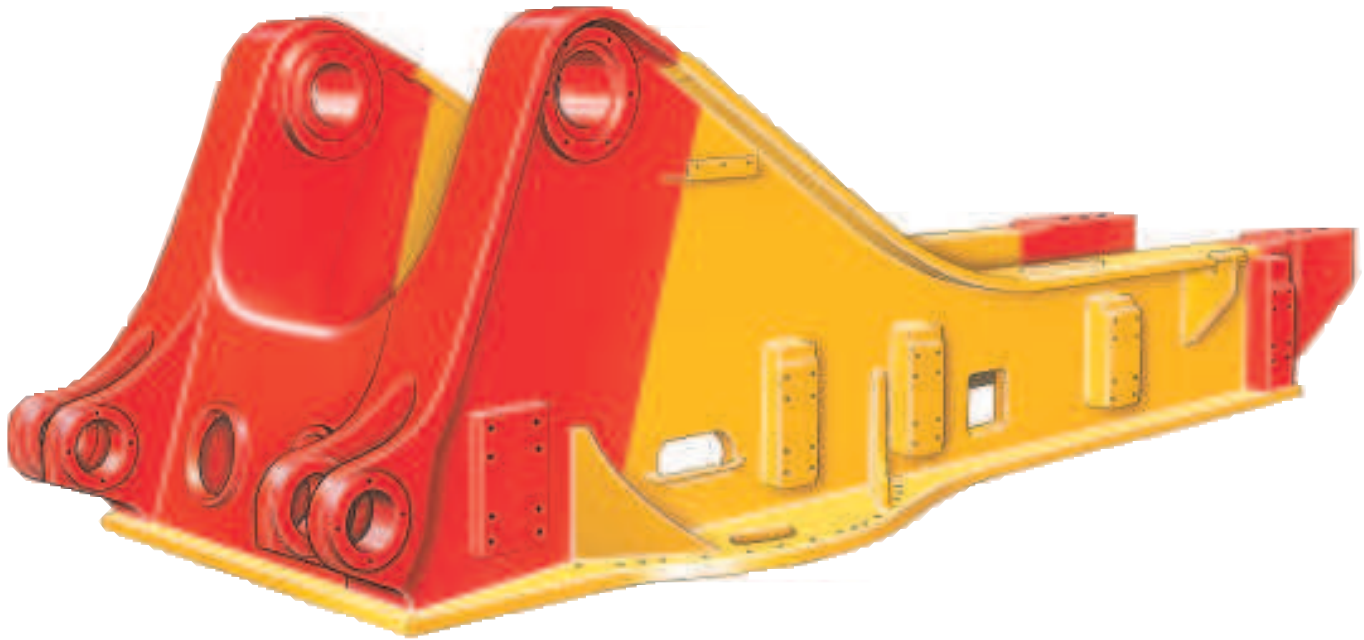

Heavy-duty castings are used extensively in high-stress areas for excellent, long-term structural durability.

Castings are used in:

- Front end of the swing frame (which is a single, massive casting)
- Counterweight mounts
- All boom and stick pin mounts
- Carbody
- Final drive mounts

Rugged box section construction

is used in key structures to provide unsurpassed strength while eliminating excess weight. Box section construction is used in the booms, sticks, carbody and roller frames.

High digging forces are a result of the efficient front linkage. Rod-ported bucket tilt cylinders eliminate external return lines, improving seal and rod life.

One piece floating pins are used at swing frame to boom, boom to stick and stick to bucket joints for extra strength and life.

Front structure components are thermally stress relieved to reduce residual stresses from the welding process, increasing structure life.

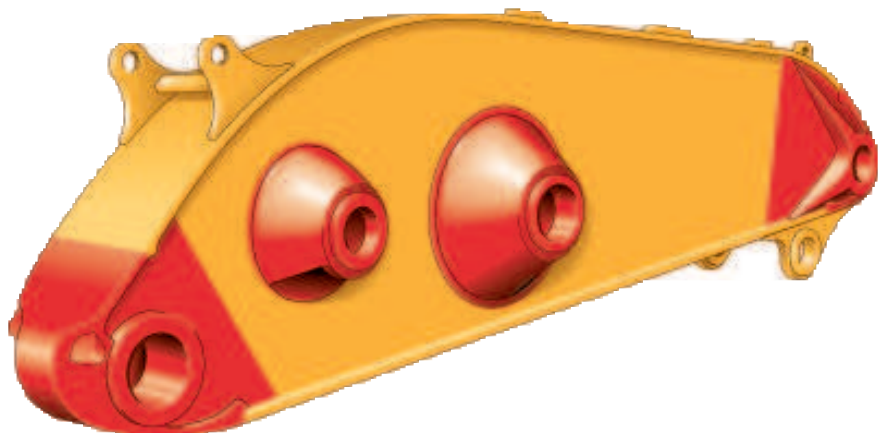

Undercarriage

Durable, maintenance-free undercarriage absorbs stresses and provides excellent stability.



A wide track gauge offers the stability needed for top production.

The moving undercarriage is a no-maintenance system that includes some of the same features found on the dependable D11-size track. Cat sealed and greased track eliminates the need for grease packing or shimming.

Track roller frames hold moving undercarriage components rigidly in place. They also absorb stress loads transmitted from the carbody.

- Castings and high-strength steel fabrication in crucial areas provide superior structural strength.
- Box beam section design includes internal stiffening plates to provide added strength.
- Top plates are inclined to reduce material build-up and packing under carrier rollers.
- Track motors and hydraulic lines are fully guarded.

Automatic track tensioning maintains the correct track tension.

- A gear pump supplies pressurized oil to a cylinder, extending a push rod which is attached to the idler.
- Check valves hold the pressure in the cylinder and maintain the correct track tension when the engine is not operating.
- For periodic maintenance, there is a manual release located on the track roller frame.
- Shock loads on the cylinders are absorbed by an accumulator and protected by a line relief valve.

Three shoe widths are available to match your application.

- Rock
- General Purpose
- Soft Underfoot

Operator's Station

Designed for comfort and ease of operation.



Spacious operator compartment measures 1790 mm (5'10") wide by 2178 mm (7'2") long by 2236 mm (7'4") high and has an exceptional, unobstructed view of the bucket and loading area.

- Cab offers ample leg room to the front of the operator's seat.
- Trainee seat with seat belt at the rear of the cab has cooler-size storage under the seat cushion.

Cab and nearby components are isolated to dampen sound and vibration.

- Operator sound levels have been field tested at or below 68 dB(A) with the air conditioning on, doors closed and the engine at rated speed.
- Hydraulic controls are pilot operated for low lever efforts and excellent control.

Air pressurization with positive filtered ventilation keeps the cab environment comfortable and clean.

- Two fresh air filters remove dust and particles before circulating.
- Every side window has its own vent.
- Front window has two large-diameter vents to maintain excellent all-around visibility, even in frost conditions.
- Foot level vents and two large-diameter vents in the console are devoted to the operator.

Contour series seat is fully adjustable for shift-long comfort.

- Seat cushions reduce pressure on the lower back and thighs.
- Short armrests allow freedom of movement with the joystick controls.
- Joystick control consoles can be repositioned independently according to operator's preference.

KAB seat is available as an option.

- Weight-compensated support.
- Three-way seat cushion adjustment.
- Backrest is adjustable from 56° forward to 82° reclined.

Vital Information Management System (VIMS)

Provides operators, service technicians and managers with crucial operating data.

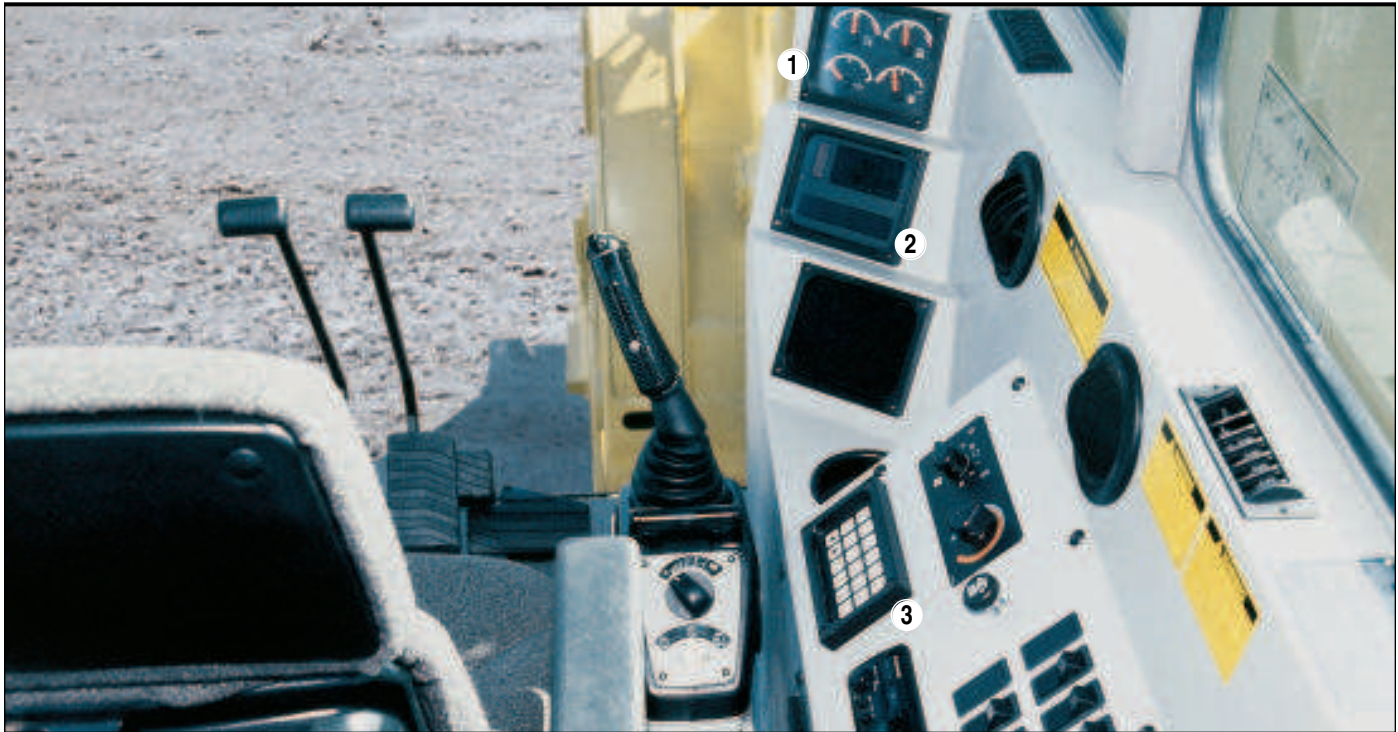

The VIMS system continuously displays critical machine data. This information can be used to keep the 5130B performing at top production levels.

1. Upper screen display. On its upper screen, the VIMS maintains a constant display of four critical machine functions.

- Engine coolant temperature.
- Hydraulic oil temperature.
- System air pressure.
- Fuel level.

2. Lower screen display. The lower screen displays operator-requested information and also contains the VIMS three-category alert system.

- Display fields include both a numeric reading in English or Metric units (e.g. degrees of temperature) and an electronic gauge which illustrates the function's current position relative to a predetermined limit or setting.

3. VIMS keypad allows the operator to access current machine system information from twenty-by-two VIMS display fields. The keypad is also used by service personnel to access diagnostic information.

The three-category alert system

provides advisory information to the operator when conditions in a monitored system exceed a prescribed setting for ordinary operations.

- The **advisory category** activates an alert indicator lamp when a system condition has been identified and appropriate corrective action is recommended.
- In the **operator advised category**, an action lamp flashes in addition to the level one display.
- **Immediate shutdown advised**, the final category, sounds an audio action alert in addition to the category two action. The action lamp and alert remain on until the system reading returns to normal or the machine is shutdown.

The VIMS diagnostics program

allows service personnel to download a complete record of machine data events and system diagnostics to a lap-top computer.

- This information can be used to establish a baseline for machine performance in specific applications or to improve the effectiveness of scheduled maintenance programs.
- VIMS data makes it possible to correct minor problems before they cause extensive damage, which can result in costly down time.

Buckets

Aggressive bucket design and efficient linkage configuration promote high bucket fill factors.



High fill factors for the 5130B Front Shovel and Mass Excavator set this machine apart from the competition. Caterpillar's quality design improves breakout and crowd forces, increasing fill factors.

- **Linkage geometry** optimizes mechanical advantage through the loading cycle.
- **Curved floor bucket design** moves the bucket fulcrum away from the cylinders, increasing breakout force; promotes smooth material flow to the back of the bucket.

Box-section construction is utilized in the dozer portion of front shovel buckets to provide torsional strength when the bucket is closed for digging.

Steel castings are used in high-stress areas such as the dozer hinges, bowl pivots, cylinder mounts, and corner adapters.

Hardened bearings improve the durability of the pivot and cylinder mounts in mass excavator buckets.

Heat-treated steel is used to improve the service life of corner and center adapters, cutting edges and side bars which will be subjected to more abrasive conditions.

Standard wear plates on the back, sides and bottom reinforce front shovel bucket structures. Wear packages with Abrasion Resistant Material (ARM) are also available for high abrasion applications.

Bucket tips are top-pinned directly to the adaptor for fast on-site replacement. General purpose rock and penetration tips are available to maximize penetration and tip life.

Several front shovel and backhoe buckets are available. Buckets range from rock/high density buckets to coal and light material buckets. Contact your dealer for a precise match to your application.

Modular Design

Provides a stable, productive machine that's easy to transport and service.



Shipping and assembly. Machine breaks down into eight modules for ease of shipping.

- Swing frame and carbody ship as a single unit which means the swing bearing doesn't need to be assembled or disassembled.

Maintenance and service access.

The right and left side modules provide excellent service access as well as storage and working space.

Right module includes walk-around, lighted access to the engine, engine cooling system, batteries, and hydraulic pumps.

Left module includes cab riser which allows stand-up access to hydraulic pilot lines and to the main junction box for electrical and electronic components. It also includes a sheltered, lighted service area for the hydraulic tank, filters, hydraulic cooling system and auto-lube reservoir.

Superior stability is achieved by creating a lower center of gravity and is a result of the modular design.

- The left and right side modules are positioned low in relation to the swing frame module.
- The longitudinal mounting of the engine in the right side module makes this stable, low positioning possible.

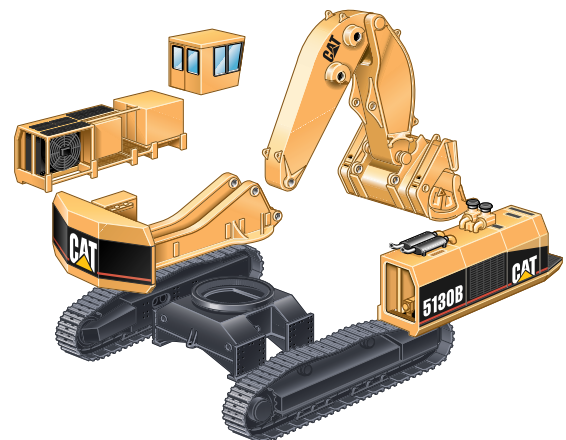

Engine

Caterpillar, four cycle, 3508B twin turbo-charged and aftercooled, diesel engine with electronic unit injection.

Ratings at 1750 rpm*	kW	hp
Gross power	641	860
Net power	597	800

The following ratings apply at 1750 rpm when tested under the specified standard conditions for the specified standard:

Net power	kW	hp
Caterpillar	597	800
ISO 9249	597	800
SAE J1349	591	792
EEC 80/1269	597	800
DIN 70020		829

Dimensions

Bore	170 mm	6.7 in
Stroke	190 mm	7.5 in
Displacement	34.5 liters	2105 cu in

*Power rating conditions

- based on standard air conditions of 25°C (77°F) and 99 kPa (29.32 in Hg) dry barometer
- used 35° API gravity fuel having an LHV of 42 780 kJ/kg (18,390 Btu/lb) when used at 30°C (86°F)
- net power advertised is the power available at the flywheel when the engine is equipped with fan, air cleaner, muffler, and alternator
- no derating required up to 3050 m (10,000 ft)

Features

- Cat electronic control system monitors operator and sensor inputs to precisely optimize engine performance, at that altitude, with electronic unit injectors
- two hard-faced inlet and exhaust valves per cylinder, valve rotators and hard alloy-steel seats
- self-aligning roller followers on camshaft
- two-piece pistons with steel crown (three rings) and thermally isolated aluminum skirt
- direct-electric, 24-volt starting system with 100-amp alternator and four 210-amp-hour, low-maintenance, high-output, 12-volt batteries
- deep bowl combustion chamber

Hydraulic System

The hydraulic system for front structure and travel functions is supplied by four, variable displacement pumps. A separate variable displacement pump provides for the swing function.

Main system, piston-type pumps, closed center

Output at 1915 rpm	375 liters/min (x 4)	99 gpm (x 4)
--------------------	----------------------	--------------

Relief valve setting

Travel	35 000 kPa	5000 psi
Front structure	31 000 kPa	4500 psi

Swing system, piston-type pump, open center

Output at 1915 rpm	450 liters/min	117 gpm
--------------------	----------------	---------

Relief valve setting

Accelerating	35 000 kPa	5000 psi
Decelerating	25 000 kPa	3620 psi

Pilot system, gear-type pump, open center

Output at 1915 rpm	56 liters/min	14.5 gpm
--------------------	---------------	----------

Relief valve setting

Controls	4000 kPa	580 psi
Track Tension	7000 kPa	1000 psi

Features

- main hydraulic pumps are electronically controlled and dependent on engine speed
- engine automatically idles down with inactive controls and resets to original speed upon control engagement
- work cycle performance is optimized during single-function, high front structure speed requirements by combining pump flows
- all valves are pilot operated for ease of operation and excellent control
- all lines include primary and secondary relief valves as well as anti-cavitation valves

Swing Mechanism

Hydrostatic with independent planetary reduction.

Ratings

Swing Torque	587 kN·m (433,240 lb·ft)
Time for 90° lift and swing (loaded bucket)	7.3 sec

Features

- power for the swing mechanism originates with two hydrostatic motors with independent planetary reduction and integral multiple disc brakes
- internal gearing is totally enclosed, and is continuously lubricated together with the pinion

Drive

Drive system is fully hydrostatic.

Ratings

Maximum Drawbar Pull	872 kN	(196,000 lbs)
Maximum Travel Speed	3.3 kph	(2.1 mph)

Features

- each track is driven by an independent, bent-axis piston motor via integral planetary final drives
- multiple disc brakes are spring engaged, pressure released; each drive module is well integrated into the roller frame for total protection

Brakes

Service brake features

- two wet, multiple-disc brakes are used on the final drive input shafts
- spring-applied, hydraulically released
- actuating a travel control simultaneously releases the brakes
- when the controls are released, the brakes automatically apply

Parking brake features

- wet, multiple disc brakes
- spring applied, hydraulically released

Track

Purpose built excavator undercarriage with cast, extreme service shoes.

Choice of

- 650 mm (26") shoes/Rock
- 800 mm (32") shoes/General Purpose
- 1000 mm (39") shoes/Soft Underfoot

Ground Pressures

Front Shovel

with 650 mm (26") shoes	216 kPa	31.4 lb/in ²
with 800 mm (32") shoes	178 kPa	25.8 lb/in ²
with 1000 mm (39") shoes	144 kPa	20.9 lb/in ²

Mass Excavator

with 650 mm (26") shoes	218 kPa	31.6 lb/in ²
with 800 mm (32") shoes	179 kPa	26.0 lb/in ²
with 1000 mm (39") shoes	145 kPa	21.0 lb/in ²

Features (per side)

- 48 track shoes
- 8 track rollers
- 2 carrier rollers
- 2 track guiding guards

Steering

Two rocker pedals with detachable hand levers control steering and travel functions.

Controls

- controls are pilot-operated for reduced efforts
- left pedal and lever control left track; right pedal and lever control right track
- when idlers are in front, pushing both pedals or levers forward moves the excavator straight ahead
- rocking both pedals or pulling both levers backward moves the excavator straight back
- moving one pedal or lever more than the other, either forward or backward, results in a gradual turn
- moving one pedal or lever forward and the other pedal or lever backward counter-rotates the tracks for spot turns

Front Structure Controls

Two joystick hand levers actuate boom, stick, bucket and swing (SAE pattern).

Boom/Bucket Controls (Right Joystick)

- move forward and backward to lower and raise boom
- move left and right to control bucket curl and dump
- button on top is boom float control (Front Shovel only)

Stick/Swing Controls (Left Joystick)

- move forward and backward to move stick out and in
- move left and right to control direction of swing
- button on top controls horn

Other Features

- oblique movement of either lever operates two functions simultaneously
- manually applied lever on left console cuts off pilot pressure for joysticks and travel controls and electrical power for engine starting circuit

Service Refill Capacities

	L	Gallons
Fuel Tank	2600	687
Cooling System	300	79
Engine Oil	125	33
Pump Drive	73	19
Swing Drive	14	3.7
Final Drive (each)	31	8.2
Hydraulic System (including tank)	1800	476
Hydraulic Tank	1225	324

Cab

Caterpillar cab with integral Falling Object Guard is standard in North America, Europe and Japan.

Cab Certifications

- The cab structure is designed to protect the operator from falling objects, and is certified under SAE J1356 FEB88 and ISO 3449-1984 specifications. A guard is available for the front windshield and is also certified under SAE J1356 FEB88. Currently there is no ISO specification for front guard structures.

Note

When properly installed and maintained, the cab offered by Caterpillar, when tested with doors and windows closed according to ANSI/SAE J1166 MAY90, meets OSHA and MSHA requirements for operator sound exposure limits in effect at time of manufacture. The operator sound pressure level is 68 dB(A) when measured per ISO 6394 or 86/662/EEC.

Dimensions

All dimensions are approximate.

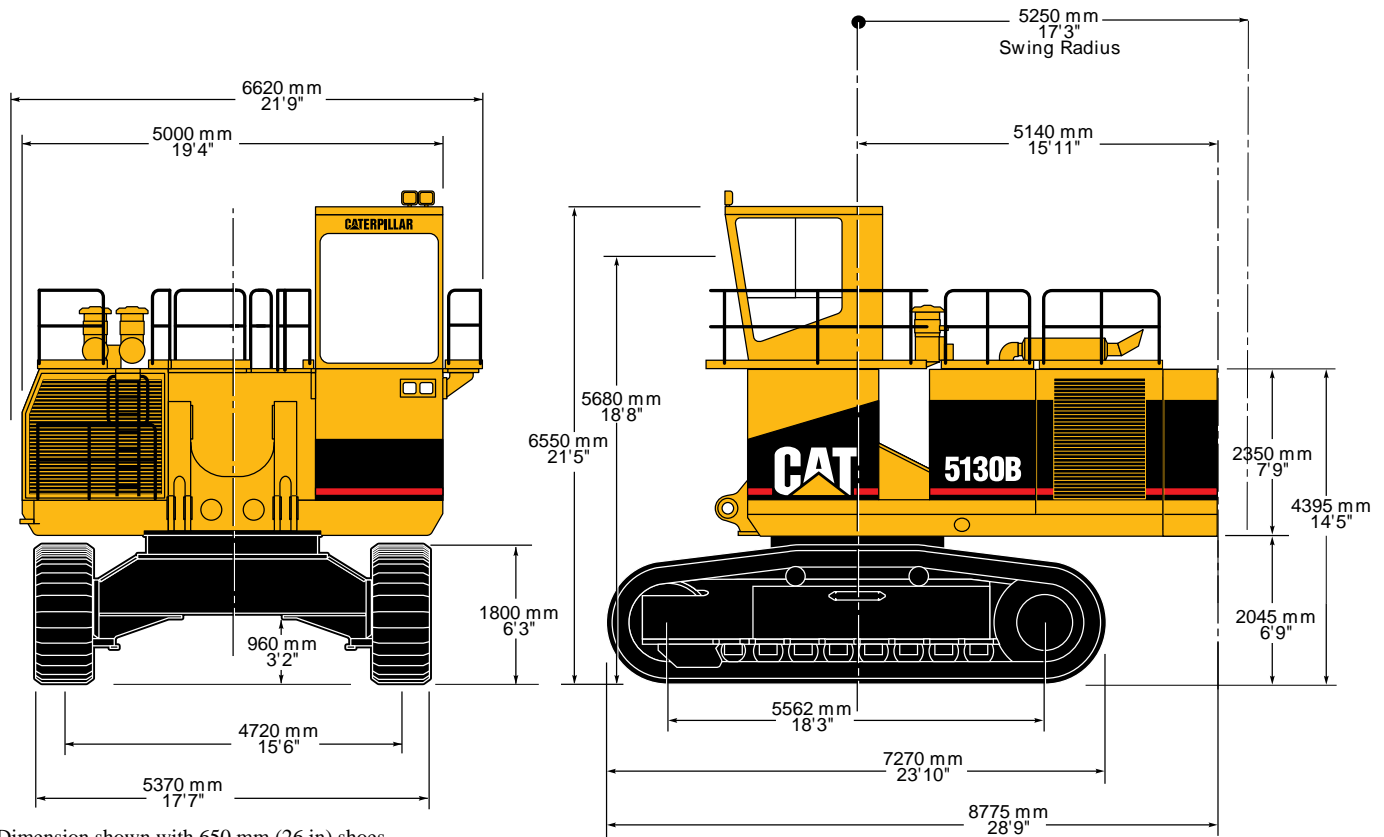

* Dimension shown with 650 mm (26 in) shoes

Supplemental Specifications

Shipping Dimensions*

Truck	Module	Weight		Length		Width		Height	
		kg	lb	mm	in.	mm	in.	mm	in.
1	Carbody/Swing Frame	38 630	85,160	7061	278	4115	162	3962	156
2/3	Track Roller Frame (x2)								
	650 mm (26") shoes	23 610	52,060	7137	281	1499	59	1905	75
	800 mm (32") shoes	24 640	54,320	7137	281	1499	59	1905	75
	1000 mm (39") shoes	25 770	56,820	7137	281	1499	59	1905	75
4	Left Hand Enclosure	8050	17,740	5766	227	2337	92	2616	103
	Cyl. Skid (x4)	FS 1800	3960	3835	151	914	36	610	24
	Cyl. Skid (x2)	ME 2800	6170	3835	151	914	36	686	27
	Cyl. Skid (x2)	ME 2000	4410	3835	151	914	36	686	27
	Cab	1810	3990	2337	92	2007	79	2997	118
5	Right Hand Enclosure	13 810	30,440	5664	223	2438	96	3048	120
	Stick	FS 6170	13,610	4928	194	1524	60	1778	70
	Parts Box/Ladder	ME 1910	4210	2235	88	1092	43	1194	47
	Parts Box	ME 1930	4260	2235	88	1092	43	991	39
	Handrail Skid	ME 930	2040	3988	157	2286	90	1118	44
6	Boom	FS 15 260	33,640	6401	252	2032	80	2108	83
	Parts Box/Ladder	FS 2940	6470	2235	88	1092	43	1194	47
	Handrail Skid	FS 930	2040	3988	157	2286	90	1118	44
	Boom	ME 20 530	45,260	8560	337	1981	78	3404	134
7	Counterweight	20 970	46,220	5944	234	991	39	2510	99
8	Bucket	FS 15 340	33,820	3683	145	2743	108	2743	108
	Bucket	ME 8560	18,870	3302	130	2718	107	2718	107
	Stick	ME 6220	13,710	5258	207	1016	40	2286	90
	Bracket Skid	ME 1370	3020	1524	60	1448	57	787	31

* Items that are not marked with an FS or an ME apply to both machines.

Standard Equipment

Standard and optional equipment may vary. Consult your Caterpillar dealer for specifics.

Action Alarm	Engine, Cat 3508B EUI Diesel
Air conditioner/heater/defroster system	Engine oil quick change system
Air cleaner, dry type, with precleaner	Lights, Halogen, working
Alarm, travel	Fuel tank — fast refill system
Alternator, 105 amp	Locks, door and cap — one key system
Automatic engine speed control	Lube reel, manual (ME only)
Automatic, air powered, Lincoln 64 l (17 gallon) capacity, lubrication system	Lube barrel, refillable
Cab, resiliently mounted, sound suppressed and pressurized (see operators station for features)	Mirrors, rearview, left on cab
Cat Underspeed Control	Seat belt, retractable
	Vital Information Management System (VIMS)

Optional Equipment

Optional equipment may vary. Consult your Caterpillar dealer for specifics.

Backhoe Arrangement
Buckets (see below)
Cold weather starting options
Engine prelube
Front Shovel Arrangement
Ground Engaging Tools
General purpose tips
Penetration tips
Edge protection
Sidebar protectors
Seat, KAB, operator
Track shoes:
650 mm/26" rock shoes
800 mm/32" general purpose shoes
1000 mm/39" soft underfoot
Windshield guard, front
Wiggins central service center

Buckets

5130B Front Shovel — Bucket Specifications

	Capacity		Weight		Width		Teeth	Mat'l Weight	
	m ³	yd ³	kg	lb	mm	in.		t/m ³	lb/yd ³
Rock	11.0	14.5	17 900	39,500	3600	142	6	1.7	2,900
Rock w/ARM	11.0	14.5	18 900	41,650	3600	142	6	1.7	2,900
High Density	9.0	12.0	17 700	39,000	3050	120	5		3550

5130B Mass Excavator Buckets — Bucket Specifications

	Capacity		Weight		Width		Teeth	Mat'l Weight	
	m ³	yd ³	kg	lb	mm	in.		t/m ³	lb/yd ³
High Density	8.5	11.0	7820	17,250	2810	111	5	2.2	3,700
Excavation	10.5	13.7	8560	18,870	2810	111	6	1.7	2,900
Rock	10.5	13.7	9750	21,500	2810	111	5	1.7	2,900
Coal	13.6	17.8	8750	19,300	3505	138	9	1.1	1,900
Coal	18.3	24.0	9200	20,300	3680	145	9	0.9	1,500

Note

Other bucket options are available. Contact your dealer for additional bucket selections.

Front Shovel Working Ranges

Front Shovel (F.S.) configuration

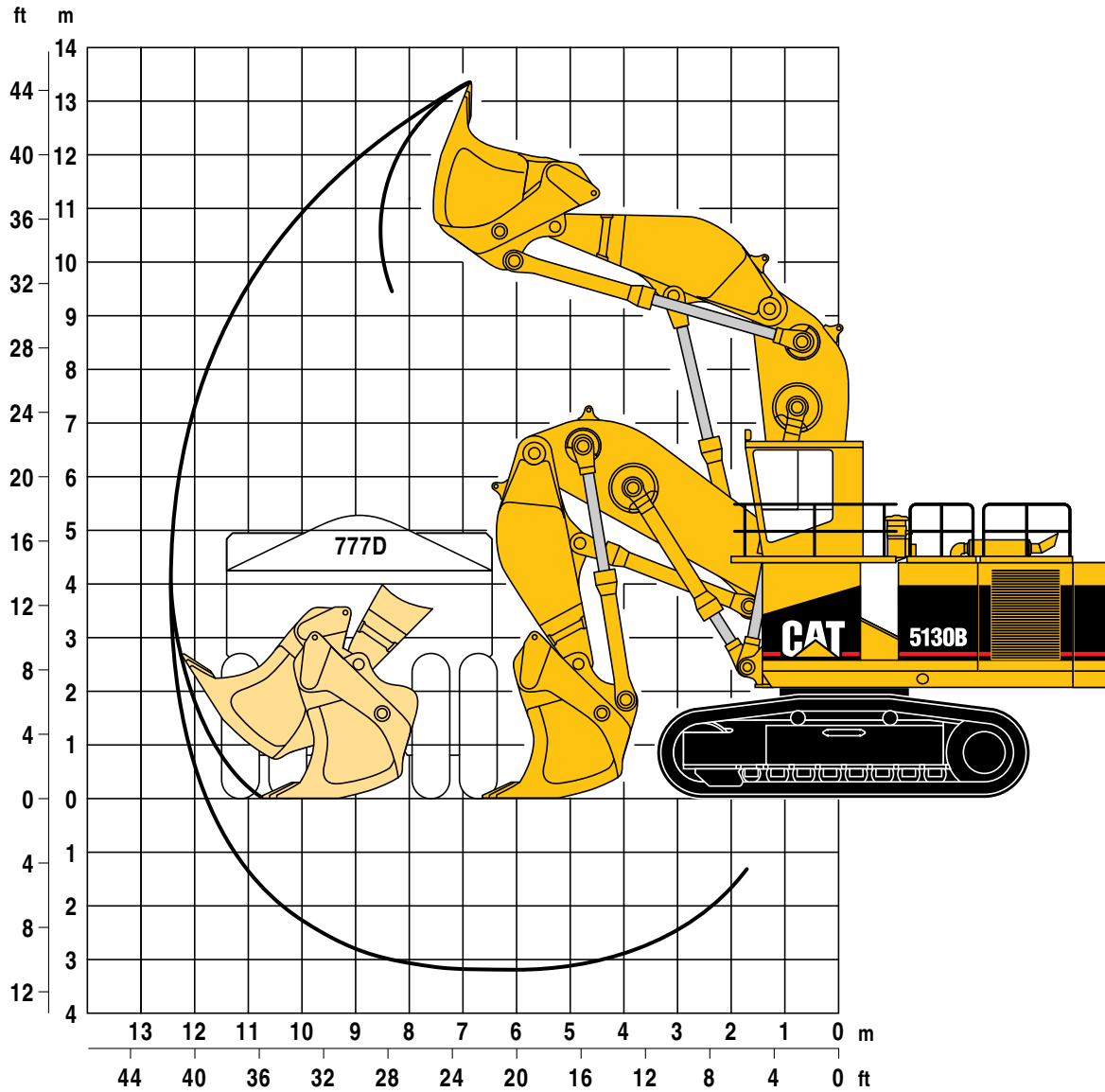

Max. Reach.....	12.4 m (40.7')
Max. Level Crowd Distance	4.3 m (14.1')
Max. Loading Height	9.1 m (29.8')
Max. Loading Height at 8 m (26') Reach.....	8.3 m (27.2')
Breakout: Force	715 kN (161,000 lb)
Crowd: Force	770 kN (173,000 lb)

Backhoe Working Ranges

Mass Excavation (M.E.) configuration

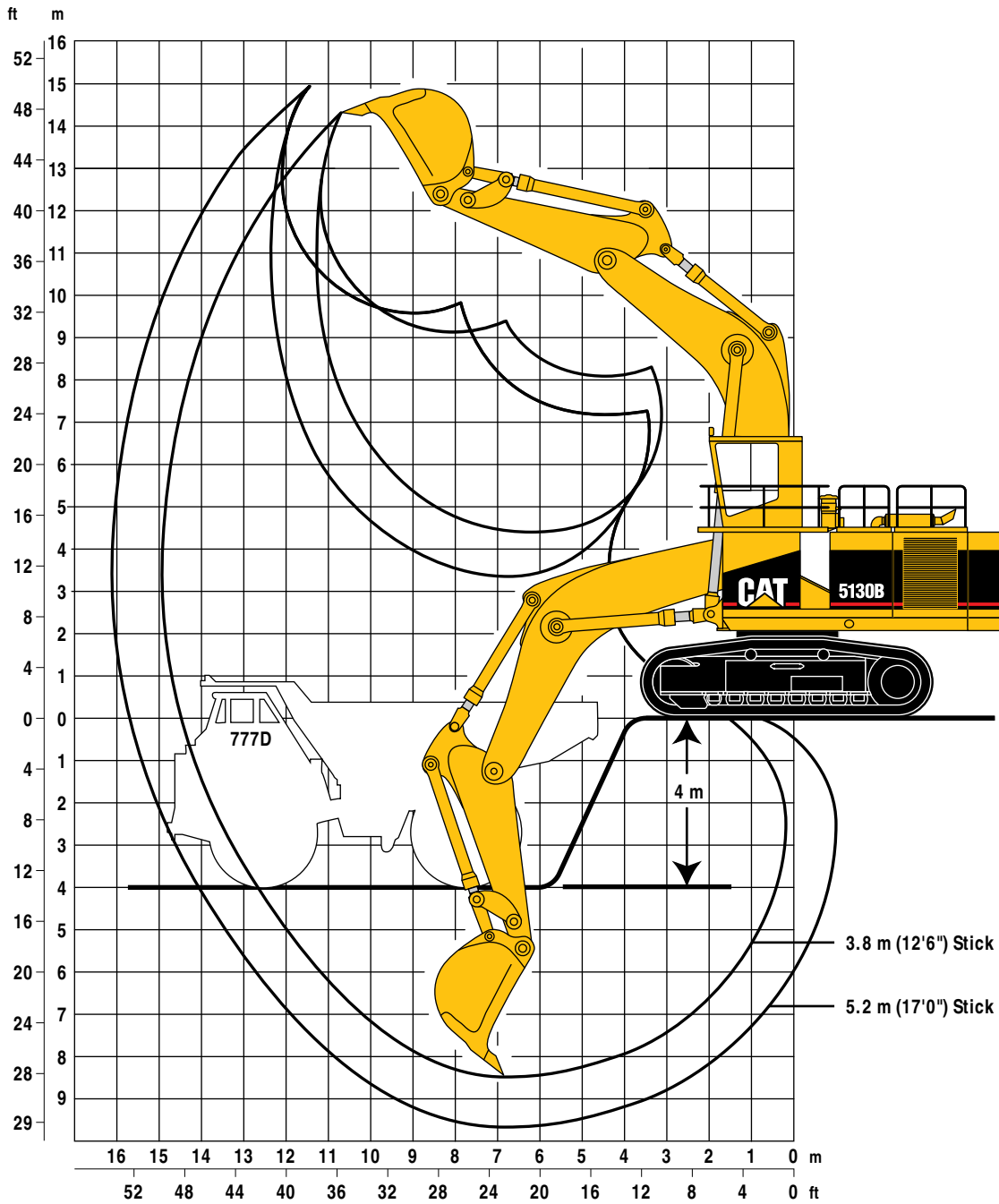

	3.8 m (12'6") Stick	5.2 m (17'0") Stick
Max. Reach.....	14.9 m (48.9')	16.2 m (53.1')
Max. Digging Depth	8.4 m (27.6')	9.7 m (31.8')
Max. Loading Height	9.1 m (29.8')	9.6 m (31.5')
Breakout: Force	672 kN (151,100 lb)	672 kN (151,100 lb)
Crowd: Force	624 kN (140,300 lb)	537 kN (120,700 lb)

5130B Hydraulic Shovel/Backhoe

AEHQ5234 (7-97)
(Replaces AEHQ5052)

www.cat.com
© 1997 Caterpillar
Printed in U.S.A.

Materials and specifications are subject to change without notice.

