

**1.** In Studio Sleeper and Aerodyne models, vista windows contribute natural light to your penthouse-like living environment.

**2.** A fold-down desk can give you plenty of extra utility – perfect for paperwork, laptop work station and in-cab dining.

**3.** Perfect for team-driving situations, Kenworth's upper berth can be secured out of the way for additional headroom when not in use.

**4.** A liftable sofa bed provides easy inside access to storage for tools, extra clothes and other accessories you need to improve life on the road.

**5.** Cabinet-mounted drawers provide convenient storage for folded clothes and other items you'd rather not place on open shelves.

**6.** Fluorescent, dome and swivel lights combine to brighten virtually every corner of your sleeper.

**7.** The optional pre-wired TV installation package includes tie-down strap, foam pad for shock absorption, 12 volt power outlet and built-in antenna for improved reception.

**8.** A multi-function center console with built-in coffee cup recesses makes the perfect cab "organizer."

**9.** Add a sunroof for additional ambient light and fresh air. Factory-installed, it's guaranteed for fit, finish and a weather-tight seal.

**10.** A high-capacity, front-loading refrigerator/freezer can be located for convenient access from cab or sleeper.

**11.** A wall-mounted console controls all of your sleeper conveniences including heating/air conditioning and ambient lighting. It even features a jack for stereo headphones.

**12.** You've even got a handy spot to file your log book.



**It's a real bonus when your truck can be made to fit this good.**

**L**ike those old work boots you've worn through so many long days they feel like part of your feet, your W900 comes formed to fit your lifestyle requirements. Precisely. • In fact, Kenworth remains one of the few OEMs to still build all its own sleepers, so you can be assured that the living environment receives the same painstaking attention to detail you'll find in the business end of your truck.

• Like the cab, your sleeper is built to go the distance, with fiberglass and aluminum combining in a huckbolted design for long-lived, low-maintenance, weather-tight construction. Bulkhead-type doors add strength to the structure. • Inside, you get a rich-looking, cab-matching interior that is hand crafted and packed with features that bring an extra measure of comfort to life on the road. Want a top-of-the-line sound system? Rear sleeper window? A cabinet with drawers or under-bunk drawers in your AeroCab? No problem. After all, it's your Kenworth.

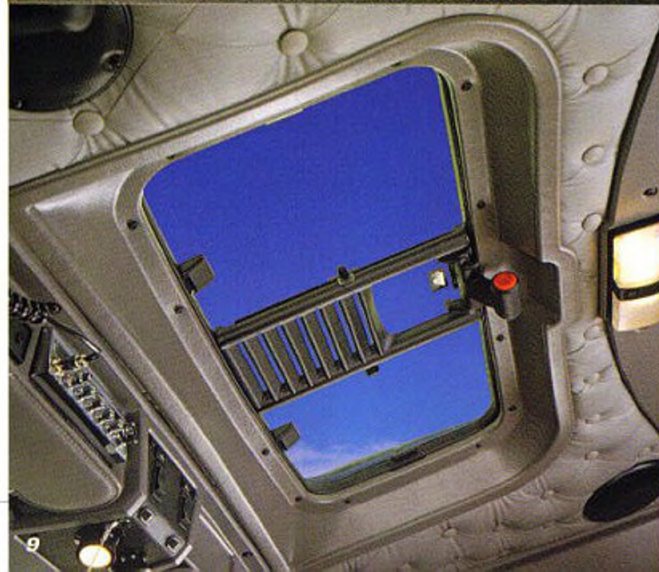
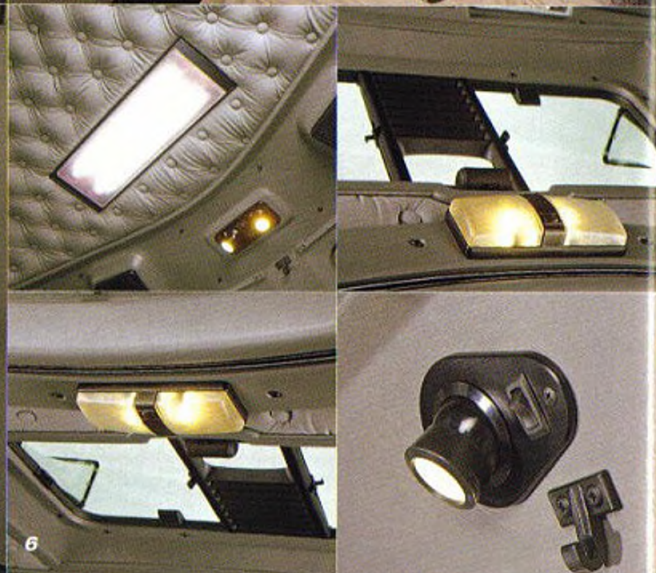
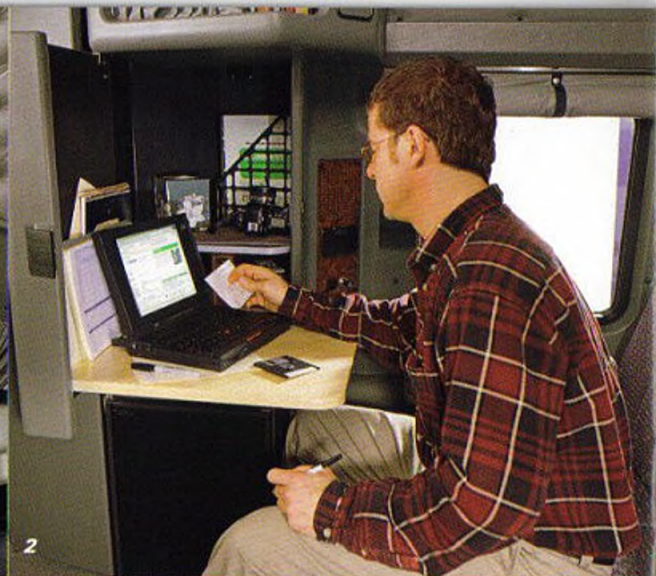



**38" AeroCab®/Splendor:**

Ideal for regional, vocational and pickup-and-delivery operations that need a highly maneuverable tractor with more versatility than a day cab provides, this compact AeroCab features plenty of headroom, over-and-under-bunk storage, full headliner, insulated rubber floor mats, 24" x 78" tilt up mattress, vented access doors, swivel reading light, lockable luggage compartments and even separate sleeper control console.

(Interior color shown in Slate Gray)

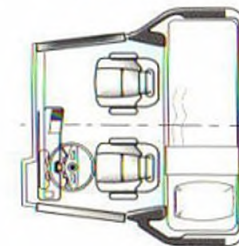



1. Kenworth offers cowl-mounted stainless steel or painted air cleaners from Donaldson, Farr or Vortox.
2. Add chrome bezels for instrumentation with ornamentation.
3. A Kenworth nameplate, located right behind the fender, serves as proof that your W900L is one of the longest long-nosed conventionals on the road.
4. Kenworth's optional Electronic Vision System incorporates a miniature curbside video camera to provide a wide-angle view of the vehicle's right side during lane changes and tight turns.
5. Stainless steel door kick panels combine practicality and good taste.
6. Kenworth-built polished aluminum fuel tanks are available in capacities to 150 gallons.
7. A traditional Kenworth gullwing or rectangular Texas-style chromed steel bumper adds a lot of accent – up front. Stainless steel eyebrows over headlights and fog light screens are also nice touches.
8. Simply input a street address and your optional on-board GPS Navigation System provides turn-by-turn visual and audio directions to help optimize route decisions.
9. Dress up your shift boot with this stainless steel frame wearing the Kenworth W900 logo.
10. This decorative stainless steel frame unequivocally emphasizes your choice in trucks.
11. To top things off, you can get round or rectangular horns and marker lights; painted fiberglass or stainless steel sunvisor; even a factory-installed antenna and hookup for your cell phone.
12. To make the miles pass quicker, Kenworth offers a full line of premium sound systems to choose from. Whether your preference is cassette, CD or the latest in satellite radio, Kenworth has you covered. Satellite capable radios are factory installed, all you have to do is add a receiver and antenna from your satellite radio provider and you are ready to enjoy coast to coast reception.



**The W900 is built on a proven platform cleverly engineered so that the deeper you look, the more there is to appreciate.**

It's easy to be attracted by the pure pleasure of owning the best, most prestigious truck on the road. But there's even more beauty under the skin – in the form of day-in, day-out dependability, mechanical integrity and longevity. • Take the cab as just one example. Legendary for its toughness, a Kenworth combines aluminum and fiberglass in an assembly that's practically corrosion-proof. Huckbolts hold all the pieces together with a clamping force six times greater than rivets, so the cab's strong, tight and more rattle-free. • Then there are all the little things you might not notice that keep big things from going wrong. Wiring and plumbing bundled together and mounted high in the frame, safe from chafing, road salts or washing acids. Threaded steel shackle pins and bushings to extend suspension life and improve steering. Constant torque hose clamps. Radiator tie rods mounted to frame – not the cab – for longer cab life. And so much more. • It's this kind of attention to detail that keeps you moving ahead. Day in, day out.

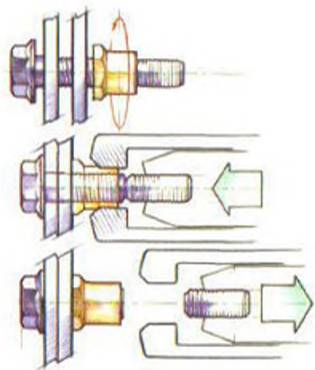

*Huckbolts hold with six times the clamping force of normal rivets, resulting in a cab that's strong, durable and more rattle-free.*

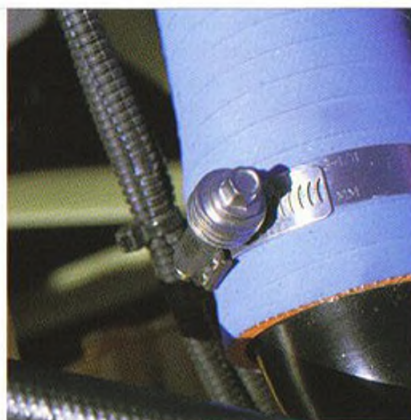

*Constant torque hose clamps – standard on Kenworth trucks – go on tight and stay that way.*



*Coil-coated aluminum panels and a one-piece fiberglass roof, supported by an aircraft-grade aluminum alloy frame, produce a lightweight yet durable cab that is virtually immune to rust.*

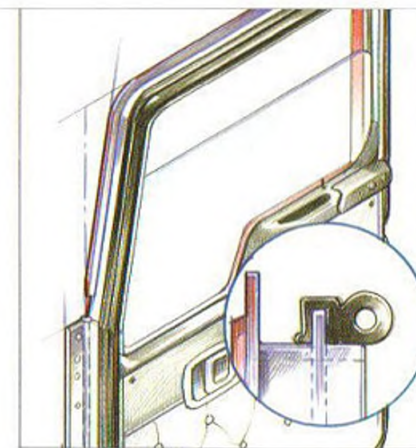

*Thick bulkhead-type doors hang on continuous stainless steel piano hinges – not typical automotive hinges – and fit snugly to become an integral part of the cab structure – another reason Kenworth trucks bring more at resale than just about any other make you can name.*





**When it comes to maintenance on a W900, Kenworth's philosophy can be summed up in two words: easier and faster.**

**T**ip the hood to see what we mean. The engine sits high in the frame and totally ahead of the cab for complete access. You can check fluid levels and change fuel, oil and water filters while standing on the ground – not on a tire. The heater/air conditioner motor, electrical master connectors, windshield wiper motor and washer reservoir are all on the firewall, easier to repair. • Now take a close look at the engine cooling system. On a W900, it incorporates straight sections of reinforced rubber hose that are more readily available and much less expensive to replace than preformed hoses, along with steel elbows that are good for a lifetime of service. • Even the electrical system – a maintenance headache for most operators – has been designed for durability and streamlined troubleshooting. Modular dash panels tilt out for uncomplicated access to cab wiring that's color-coded and numbered for easy circuit tracing. • Quick-to-fix engineering features like these can mean a lot less downtime, shop time and money out of your pocket.



*The W900's power distribution box puts all circuit protection elements – fuses, relays and breakers – in one quick-to-reach location.*

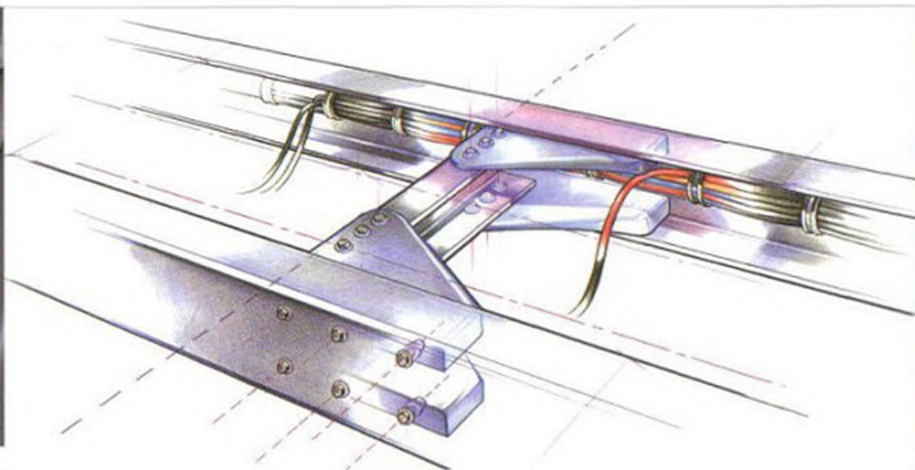

*Kenworth's frame is a continuous straight rail constructed of heat-treated steel – custom-drilled to specification – offering superior strength and longevity. Extruded aluminum crossmembers and aluminum gussets – in standard designs for easy replacement – add additional foundation without adding a lot of extra weight. And all the components are free-fit fastened for extended life. Notice how Kenworth mounts all air and electrical lines high in the frame, away from potential sources of heat, caustic chemicals and mechanical abrasion.*



*Modular dash panels tilt out to expose cab wiring that is color-coded and numbered for quick circuit tracing. Gauges are front-loading with push-on connections, a cinch to replace.*







**You've been around long enough to know that even the best truck is only as good as the quality and commitment of the people who stand behind it.**

**T** rue whether you're running across the country or across town. The reliability and money-making potential of your business relies a lot on the dependability of your support system. And that comes down to counting on people to have *your* best interests in mind. Because no matter how you figure it, the time your truck spends in the service bay costs you productive time on the job. • That's why it makes so much sense to rely on your Kenworth PremierCare dealer for the parts, service and support you need. As a Kenworth PremierCare member, you've got priority access to the experts who know your truck inside and out. People dedicated to keep you running nonstop. People you can trust to stand behind their work. People who appreciate, perhaps better than most, that you're not in business to merely own trucks, but to profit from them.

*Kenworth PremierCare Preventive Maintenance: Here's your best route to maximum up-time, lower operating expenses and maintenance costs you can actually predict, budget and schedule. Tailored to fit the way you operate, this PM program – equivalent to just a few cents a mile – incorporates factory recommended procedures, annual government safety inspections and the common sense judgment of truck experts to optimize truck performance.*

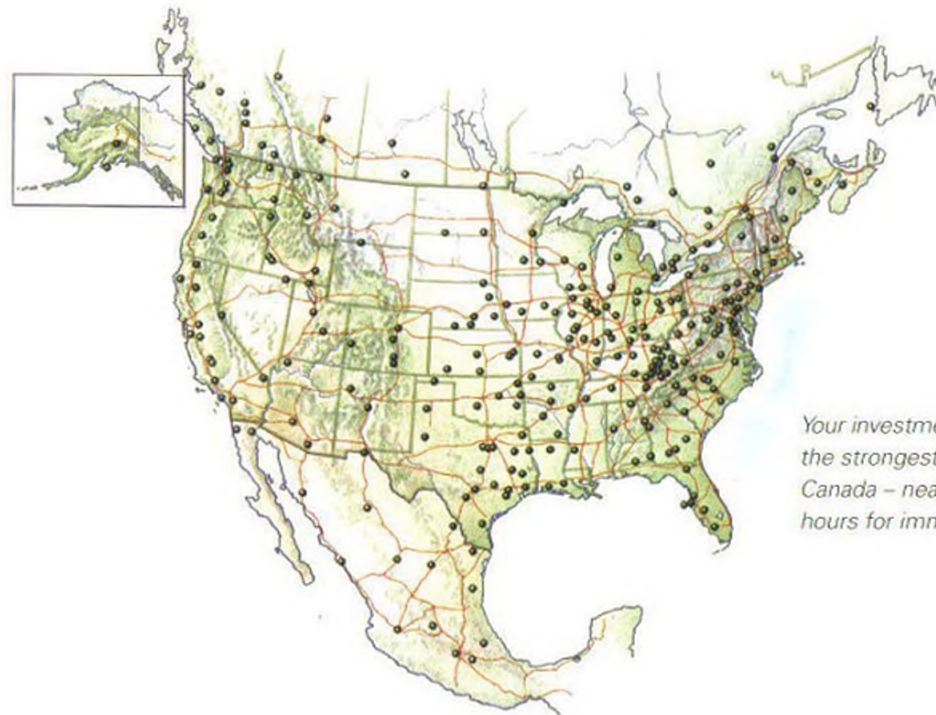

*1-800-KW-ASSIST: For those inevitable times when the unexpected happens – no matter where you are in the United States and Canada or when – you can count on the Kenworth PremierCare toll-free hotline to help get you out of trouble as quickly as possible. Consider it part of Kenworth's commitment to do whatever it takes to help you get where you're going.*

*Your investment in a Kenworth truck is backed by one of the strongest dealer support systems in the U. S. and Canada – nearly 300 locations, many open extended hours for immediate access to parts and service.*



**42" Modular FlatTop/Diamond:**

Here's a compact and affordable model with plenty of style! Available in either a Splendor Interior or Kenworth's legendary optional Diamond Interior (shown) with deeply padded vinyl upholstery throughout, wall-to-wall carpet, vented access doors, over- and under-bunk storage, 39-inch mattress, lockable luggage compartments and separate sleeper control console.

(Interior color shown in Slate Gray)

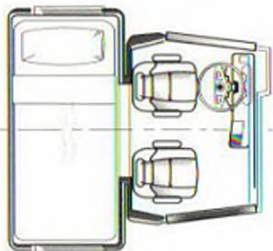

**62" AeroCab®/AERODYNE®/Diamond VII:**

Just 10 inches shorter than its bigger brother, the 62-inch model offers 100% AeroCab functionality and high style – offering plenty of room to stand up, move around and recline the seats. With the sumptuous Diamond Interior, you get wall-to-wall carpeting, hanging clothes closet, QuietCab® package, storage shelves, vented access doors, 32-inch mattress and floor lighting.

(Interior color shown in Bordeaux Red)

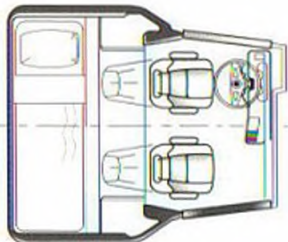
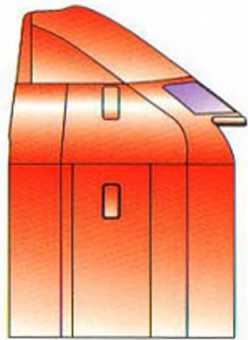



**50" Modular FlatTop/Splendor:**

In applications where wheelbase restrictions are more severe, this model is right at home. Standard features include an under-bunk storage compartment, full headliner, insulated rubber floor mats, 32-inch mattress, clothes closet, storage shelves, vented access doors, swivel reading light, lockable luggage compartments and separate sleeper control console. Kenworth's optional Diamond Interior is shown in the cab.

*(Interior color shown in Slate Gray)*

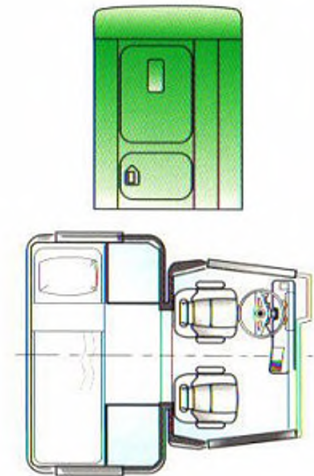

**60" Modular FlatTop/Diamond VIT:**

For those who prefer the privacy, versatility and separation of a modular sleeper, Kenworth is the only way to go. Check out the luxury in our 60" VIT. Every surface comes covered in the deeply padded comfort of Kenworth's signature Diamond Interior. This model includes wall-to-wall carpeting, vented access doors full-length hanging closet, QuietCab® package, dual speakers, generous lighting arrangement, 42-inch mattress, and plenty of stand-up dressing room.

(Interior color shown in Steel Blue)

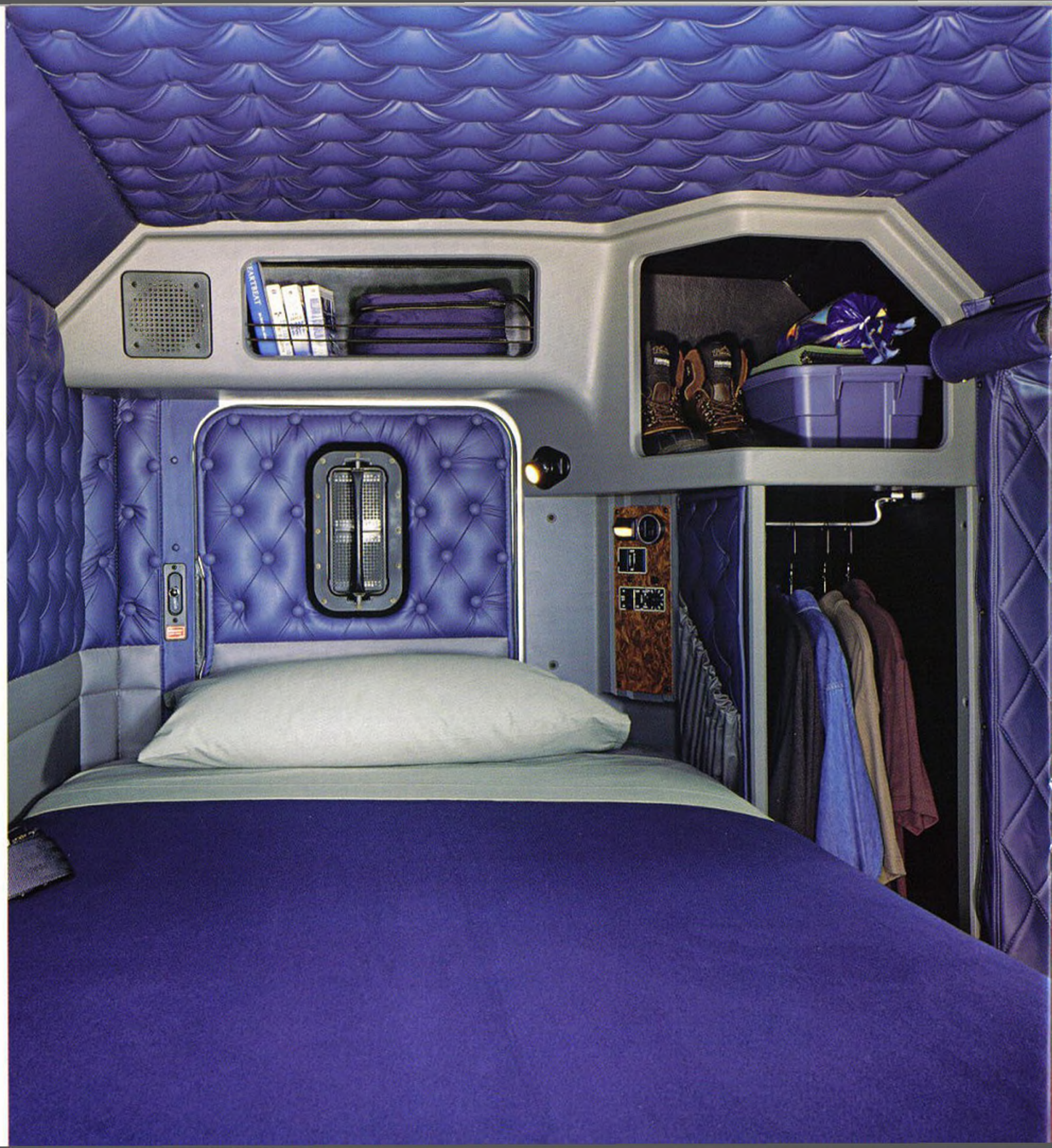
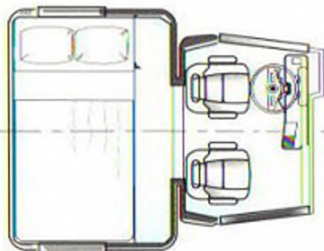
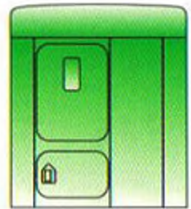



**There isn't a job anywhere that this truck can't tackle while making you look great every mile of the way.**

**C**ustom-engineered from bumper to taillight, the W900 comes any way you want it. Spec it lean for payload-hungry applications – selecting from a multitude of weight-saving options. Or order it decked out with factory-installed, signature-setting Kenworth exclusives such as polished battery boxes, tool boxes and fuel tanks. Stainless cowl-mounted air cleaners. Dual polished vertical exhaust stacks. Lighted trim panels. Roof-mounted lamps and horns. 86" Studio Sleeper. You name it. • Maybe you need a truck with some serious backbone. Dump truck. Mixer. Lowboy. Logger. W900. • Your design choices encompass the latest technologies and a spectrum of proven heavy-duty components for GCWs to 200,000 pounds or more. The highest horsepower engines. Front axles up to 18,000 pounds. Lifiable pusher and tag axles. Single, tandem and tridem drives. Numerous transmission options, including auxiliaries. Rear engine PTOs. Dual power steering. Center front tow hook. And a wide range of steel frame selections – with up to two inserts.

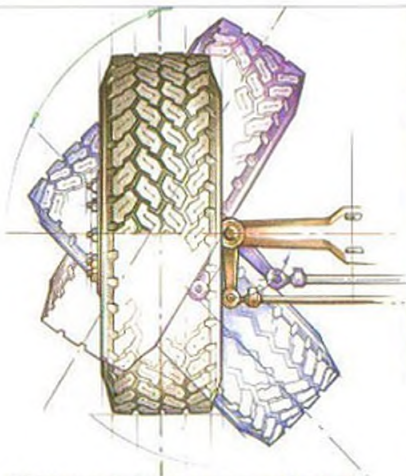

Manuverability means productivity. A Kenworth W900 manages 38 degrees of wheel cut - even with 425 section flotation tires!



Kenworth is one of the few manufacturers to build effective tri-drives – offering the pulling power of a 6 x 6 for less money and without the hassle of a transfer case or the raised front end of a front drive axle.



Optional Kenworth-built aluminum or steel diamond-plate toolboxes can be located under the cab or in back of the fuel tanks.

- 1. W900L:** The versatile W900L is as comfortable on the job site as it is on the road. Hauling heavy loads is no problem for this thoroughbred.
- 2. W900L Studio Sleeper:** Kenworth's traditional long-nose styling coupled with one of the industry's most spacious and luxurious off-duty environments. What a way to go!
- 3. W900L Studio Sleeper:** No matter what you're hauling, this is a great way to announce you've arrived.
- 4. W900 Heavy Hauler:** High horsepower and lots of cooling capacity in a heavy-duty truck that says quality all the way.
- 5. W900 72" AeroCab:** When length is a concern but the traditional look is a must, the W900 is the choice. The W900 lets you meet your length requirements without sacrifice.
- 6. W900L 62" FlatTop AeroCab:** – For applications that demand a lower profile and operators who want all of AeroCab's unique amenities and advantages.



2

4

6



Everything looks better through the windshield of a long-nosed Kenworth conventional. Inside, the ergonomic, richly finished wrap-around instrument panel places all switches and controls conveniently close at hand. Backlit non-glare gauges feature big, quick-to-read graphics. Kenworth's exclusive SmartWheel® – a great productivity option – puts 11 of the most frequently used controls right under the driver's fingertips.

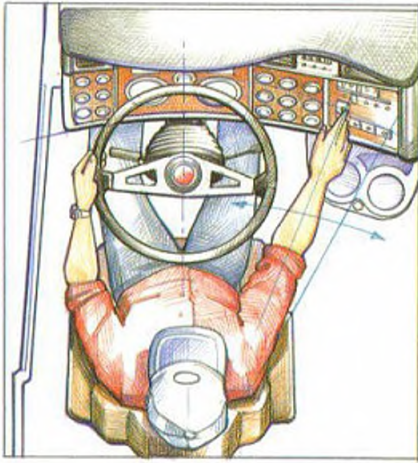

The ergonomic "fit" of a W900 is about as intuitive as modern science can make it - with instruments placed directly below the forward line of vision and every vital vehicle control conveniently close at hand.

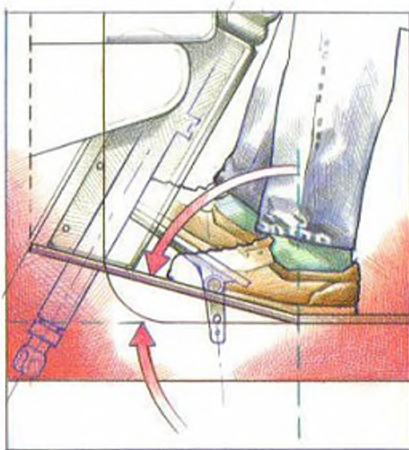

The toe board angle is flatter on a W900 than it is on most trucks, reducing leg strain and giving you more room for your feet.





**72" AeroCab®/AERODYNE®/Splendor:**

Kenworth's "standard" Splendor Interior has always been a cut above the Class 8 standard. But in AeroCab, it's even further ahead. Included in the 72-inch model are a full-length clothes closet, storage shelves, insulated rubber floor mats, vented access doors and 42-inch mattress. A wide variety of options are available, including a folding upper bunk, under-bunk drawers, QuietCab® package, TV installation kit, nylon carpet – even a liftable lower bunk with 42-inch mattress.

(Interior color shown in Slate Gray)

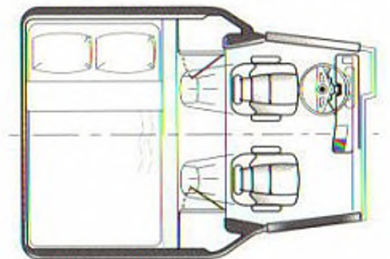
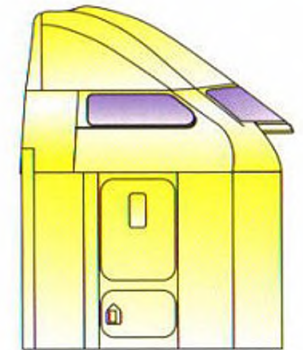

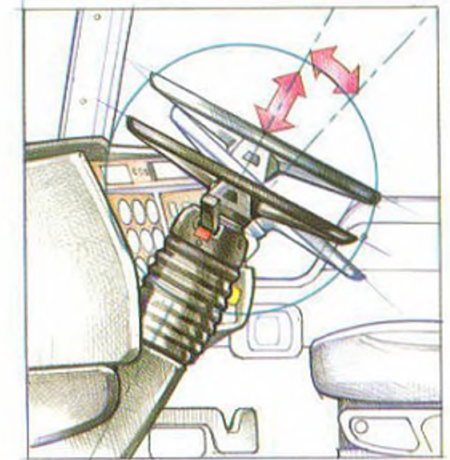

The optional adjustable steering column telescopes in or out and tilts the wheel up or down for a just-right fit every time.



An optional foot pedal release elevates the steering column for a smoother vehicle exit.

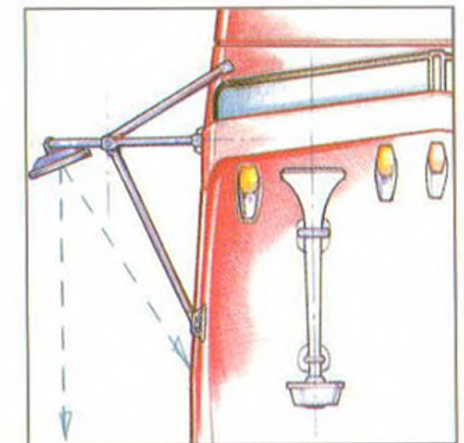

Kenworth strategically mounts mirrors on the cowl, not the door. So they are easier to view without taking your eyes off the road and stay adjusted longer.



**Like the very best of classic American design, Kenworth takes an unapologetic approach to luxury – one that embraces elegance, proportion and a perfectly natural integration of man and machine.**

Inside a W900, it's easy to understand why so many professionals would prefer to turn the key on a Kenworth than any other truck. • Deep, luxurious hand-stitched pleat-and-button upholstery and plush wall-to-wall carpet surrounds you with a rich-looking interior of unsurpassed comfort. Fully adjustable Air Cushion Premium Plus seats have been orthopedically contoured for lateral and lumbar support. The wrap-around dash layout, carrying all the gauge options you want, is logical, functional and quick to view – day or night. • In-cab storage includes a convenient place to put your thermos; upholstered behind seat pockets; slide-in logbook and pen holder; under-the-dash, multi-function center console with built-in cup holders; and more. • Then there are all the subtle things you can't see – you simply have to experience. Like Kenworth's high performance heater/air conditioner with the motor thoughtfully mounted on the firewall to keep cab noise to a minimum. The flatter toe board angle and suspended clutch pedal that reduce leg strain. And the unmistakable fit and finish of Kenworth craftsmanship.

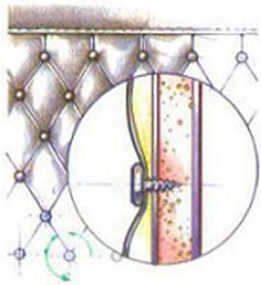

Kenworth's optional QuietCab®, incorporating high-tech sound-barrier technology, reduces interior noise by up to 50 percent.



Optional DayLite® doors provide an added measure of visibility around congested job sites and loading docks.



Air Cushion Premium Plus seats - fully adjustable for lateral and lumbar support, reclinable and available with arm rests - welcome a driver to the lap of luxury.



Getting in and out of a W900 is a walk in the park. With big, wide-opening doors, perfectly positioned traction-grip steps and generous grab handles, cab access feels just right.

► No doubt about it. Kenworth has listened to what professional drivers have to say about how to make a truck easier, less fatiguing and more productive to drive confidently. The business end of a W900 surrounds the driver with space, rich textures and a quiet, comfortable environment that elevates long-haul working conditions to a whole new level.

W 9 0 0



  
KENWORTH  
THE WORLD'S BEST

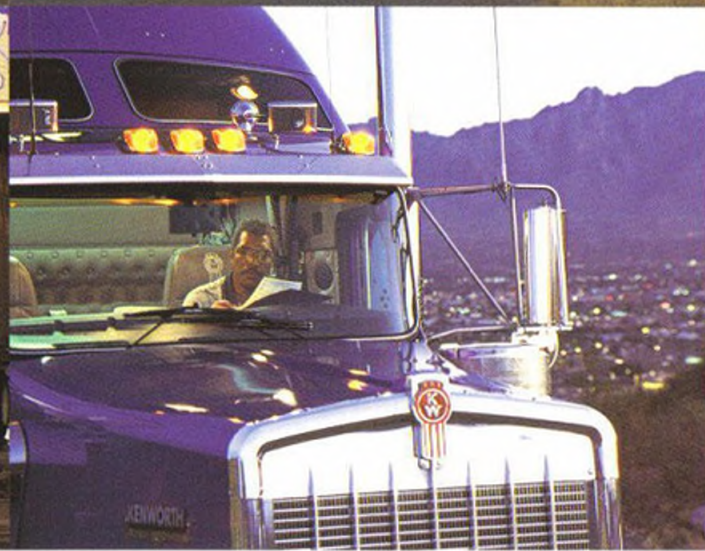
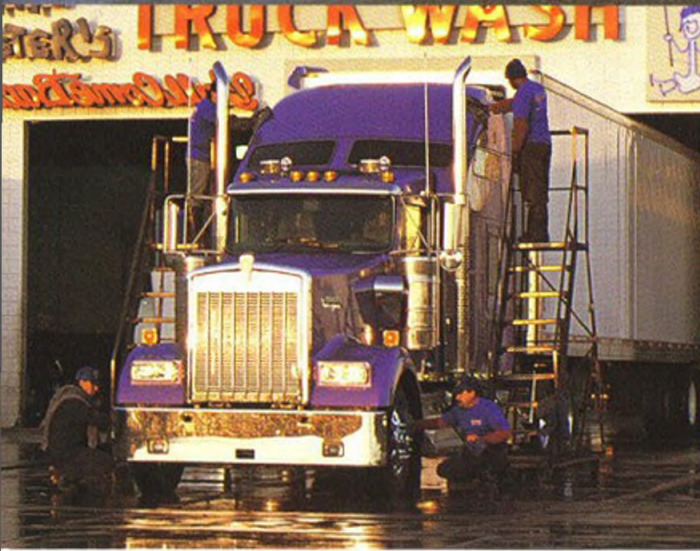



HIGH VALUE-REAL WORLD-SOLUTIONS

**Success in the hard-nosed business of moving goods from Point A to Point B means never again having to choose between a vehicle that's a pleasure to drive and one that's profitable to operate.**

**B**ecause when you've arrived, there's really only one choice to make: Kenworth W900. The perfect fusion of cutting-edge technologies, expert engineering and classic styling. It just doesn't get any better than this. • From the day it was introduced, the W900 reflected a dramatic departure in heavy-duty trucks. It brought the road to life for drivers and owners alike. Set the pace in long-haul performance, reliability, ease of maintenance, productivity and sheer luxury. Combined ready-for-anything functionality with beautifully aesthetic design like never before. And proved as comfortable



behind the wheel as it was on the bottom line. Since then, our job has been to carefully – and continually – refine the W900 without changing what made it great. • Today, few things in business exceed expectations quite like a Kenworth long-nosed conventional. Fewer still continue to excite and inspire successive generations of drivers. For many, a W900 is the ultimate goal. And no wonder. In a world of copycats, knockoffs and unrelenting parity, this is an original – a rare piece of individuality you can call your own. • Kenworth W900. A high value – real world – solution.



**At a time when mass production has largely replaced craftsmanship,  
this conventional elevates you way above the rest.**

**W**hen you drive a Kenworth W900, you own the immediate vicinity. It is a look. It is a sound. It is the undeniable recognition of your achievement.

- After all, who could ignore the sheer presence of Kenworth's W900L – with 130 inches from bumper to back-of-cab, one of the longest of long-nosed conventionals. Or miss the personalized message so clearly reflected in customized brightwork, hand-stitched upholstery and soul-stirring dual chromed stacks. Who wouldn't gaze with envy at a hand-masked, hand-finished paint job that exhibits a luster so deep you can see it for miles. Or fail to appreciate the hand-built excellence and exclusive styling of a Kenworth AeroCab or Studio Sleeper.
- A W900 blends the choices you make, from powertrain to paint scheme, with Kenworth's right-the-first-time manufacturing integrity. The result is the best-engineered, hardest-working, most luxuriously comfortable, downright awe-inspiring truck we know how to build.
- Kenworth W900. No matter where it goes, it won't go unnoticed.



*Behind this enduring symbol of excellence resides a truck that blends traditional Kenworth styling with state-of-the-art technology.*



*If you're going to tour the country with 80,000 pounds, there's no better way to do it than from the driver's seat of a W900L - one of the longest long-nosed conventionals in the industry.*



*The W900 has been called a classic without compromise. For most, it's much more than just a truck. It's absolute proof that they demand more out of life.*





**72" AeroCab® FlatTop/Diamond VIT:**

For those applications that demand a lower profile, Kenworth has designed a flat-roof model offering all of the unique AeroCab amenities and advantages. The VIT version comes with a deeply tufted Diamond Interior, wall-to-wall carpeting, door-enclosed full-length hanging closet, cabinet with two shelves, QuietCab® package, fold-down desk, over-bunk side storage compartments, and a 42-inch mattress. Options include a fold-out sofa-bed, side and rear picture windows, a TV mounting package, drawered cabinets, under-bunk drawers, liftable lower bunk, and a large-capacity front-loading refrigerator/freezer. Now that's living.

(Interior color shown in Desert Tan)

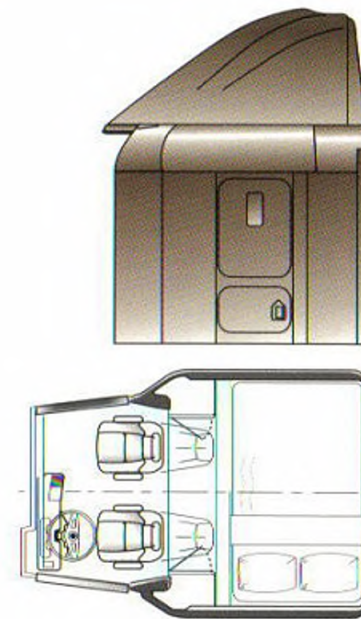





 CONFIGURATIONS

Hood Configurations



Long Hood



Standard Hood

Sleeper Configurations



86" Studio AeroCab Sleeper\*

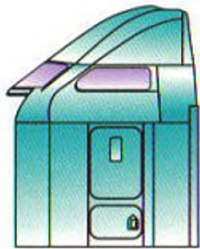

72" AeroCab/AERODYNE\*

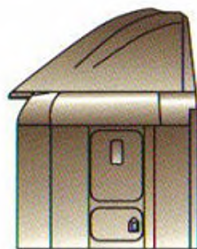

72" AeroCab FlatTop\*



62" AeroCab/AERODYNE\*



62" AeroCab FlatTop\*



60" AERODYNE II\*

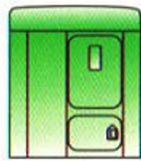

60" Modular FlatTop



50" Modular FlatTop



42" Modular FlatTop



38" AeroCab FlatTop\*

\* Sleepers shown with optional roof fairing

Note: Photography and illustrations in this brochure may depict optional equipment. Equipment and specifications shown in this brochure are subject to change without notice. Consult with your Kenworth dealer at time of ordering for standard and optional equipment.



A DIVISION OF PACCAR

KENWORTH TRUCK COMPANY

P.O. Box 1000

Kirkland, Washington 98083-1000

(425) 828-5000

CANADIAN KENWORTH COMPANY

6711 Mississauga Road N.

Mississauga, Ontario L5M4J8

(905) 858-7000



W9/03



86" Studio AeroCab® Sleeper/Diamond VIT

**72" AeroCab®/AERODYNE®/Diamond VII:**

The Kenworth AeroCab AERODYNE offers a sleek, fuel-efficient aerodynamic exterior and five more inches of headroom inside the cab. The sleeper's 7-foot-high contoured roofline incorporates vista windows for plenty of natural light and a penthouse-like living environment. Optional side and rear windows brighten your interior even more. With a deeply tufted Diamond Interior, wall-to-wall carpeting, full-length door-enclosed hanging closet, QuietCab® package, fold-down desk, 42-inch mattress or optional fold-out sofa-bed and floor lighting, it represents the ultimate long-haul lifestyle.

(Interior color shown in Slate Gray)

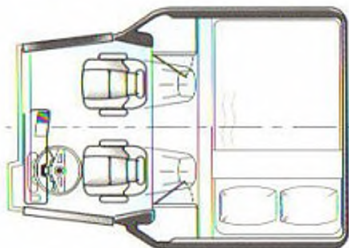
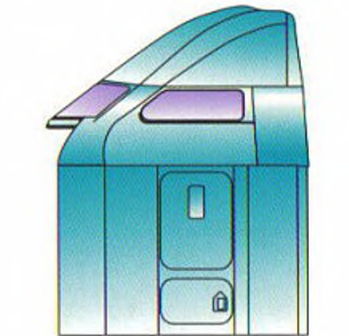



**Somewhere between shipping and receiving there's a whole lot of time in a truck. Hope it's a Kenworth.**

**W**hether you choose the economical yet workhorse-rugged Gallery interior, the way-above-standard Splendor or the custom look of a Diamond upholstery package, the inside of a Kenworth has been designed to help those behind the wheel operate at their absolute best. Perform at peak efficiency. And rest in an environment that brings them closer to home. • Tour a Kenworth Studio Sleeper, AeroCab, or one of our modulares. Note the consummate balance between business and pleasure. The thoughtful, convenient and productive layout. The creative and elegant interior appointments. All, hand-crafted to the same exacting standard we use to build the rest of your Kenworth W900. • Then imagine the pride you'd feel knowing you've been given the keys to the World's Best truck. That sense of pride is one of the reasons Kenworth trucks tend to last longer, work harder and bring more at trade-in. And one of the reasons Kenworth operators tend to keep their best drivers.

Primary Color

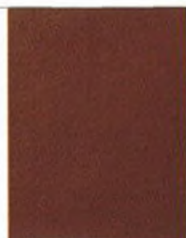
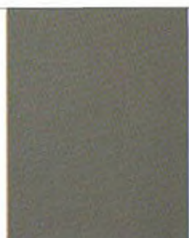

Secondary Color

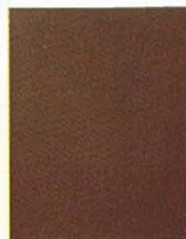
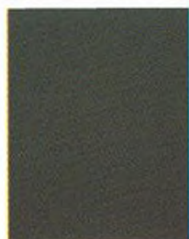
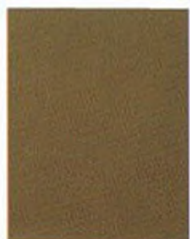
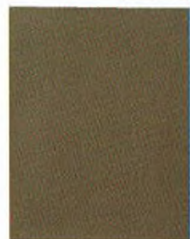

Slate Gray  
Dark Slate Gray

Desert Tan  
Dark Desert Tan

Steel Blue  
Dark Steel Blue

Bordeaux Red  
Dark Bordeaux Red

The interior of your W900 – which is hand-crafted, hand-stitched (not bonded or glued) – can be specified in five contemporary colors – including Jet Black (not shown).

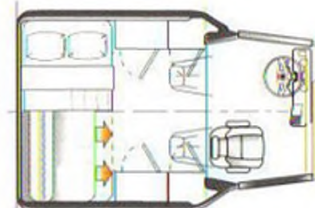
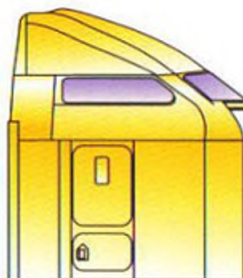

The bulkhead-free floor plan of a Studio Sleeper gives you more seat adjustment - and reclining - area. More elbow, leg and belly room. More room everywhere to stand up, stretch out and relax in style.



**86" Studio AeroCab® Sleeper/Diamond VIT:** There's comfort. Then there's comfort on a grand scale. Kenworth's 86" Studio Sleeper represents one of the most spacious and luxurious off-duty environments ever offered as original equipment by a truck manufacturer. With over seven feet of headroom, flush walk-through sleeper sill and space-conserving design features, the Studio Sleeper effectively doubles your living area compared to a conventional floor plan. Tinted picture windows, skylights and vented upper side windows further expand your sense of space as they bathe the interior in natural light. What a way to go! (Interior color shown in Slate Gray)