

EH1700

HITACHI

EH1700

Nominal Payload with Standard Equipment

88.6 tonnes (97.7 tons)

Maximum GMW with Standard Tires

170 100 kg (375 000 lb)

Engine

Cummins QST 30

Rated Power 895 kW (1 200 HP)



Designed to Perform, Built to Last



Long Frame Life

Smooth frame transitions minimize stress concentrations and steel castings effectively distribute input loads. Proven design and manufacturing methods with state-of-the-art ultrasonic testing ensure a quality product.



Technologically Advanced

The EH1700 is designed for mining and quarry applications where hauling those several extra tons per trip really matters. It provides low operating costs, unparalleled productivity, and overall quality through its superior structure and systems designs.



Unique Body Design

A single sloped floor evenly distributes material shedding during dumping. A continuously exhaust-heated body reduces carry-back of material, and muffles exhaust. Horizontal floor and side rail stiffeners distribute load shocks evenly over the entire body length, minimizing stress concentrations in any one area. Closely spaced floor stiffeners reduce wear due to impact loading.

Well Matched : EH1700 & Excavators

Excavator	EX1900-5		EX2500-5		EX3600-5	
	Backhoe	Loading Shovel	Backhoe	Loading Shovel	Backhoe	Loading Shovel
Front Bucket	12.0 m ³ (15.7 yd ³)	11.0 m ³ (14.4 yd ³)	15.0 m ³ (19.6 yd ³)	15.0 m ³ (19.6 yd ³)	22.0 m ³ (28.8 yd ³)	21.0 m ³ (27.5 yd ³)
Passes	5 - 6	5 - 6	4 - 5	4 - 5	3 - 4	3 - 4

Rugged!

Construction Tougher than the Rock It Hauls



High-Powered Engine

The EH1700 uses the high powered engine, 895 kw (1 200 HP) Cummins QST 30, providing long life while optimizing performance and reliability. Very low fuel consumption is another characteristic of this engine and it meets all emissions regulations.



Robust Frame

The frame and suspension are designed to work together to provide maximum structural integrity and operator comfort. The formed rectangular frame rail construction provides superior resistance to bending and torsional loads while eliminating unnecessary weight.

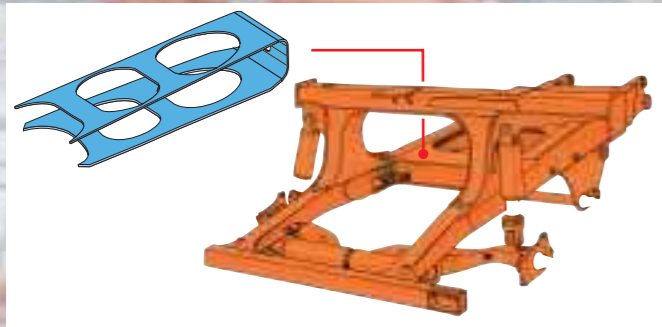

Reinforced Body

Built for quarry and mining applications, the EH1700 body uses an 17 mm (0.67") floor plate and 8 mm (0.31") side plates made of 400 BHN high-tensile steel. This provides high resistance to wear and impact. A low loading height and large target area allow easy, quick loading by a variety of loading tools.

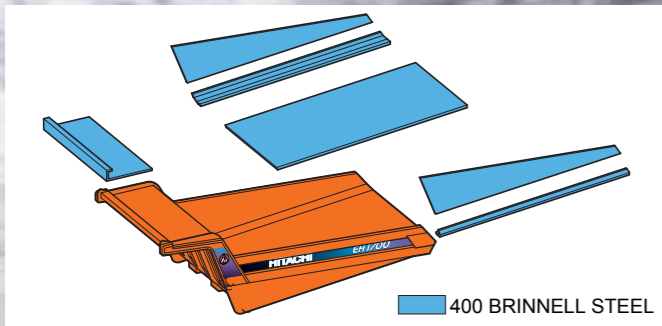

ROPS/FOPS Cab

Integral ROPS (Roll-Over Protective Structure)/FOPS (Falling-Object Protective Structure) cab is designed to offer maximum operator protection.

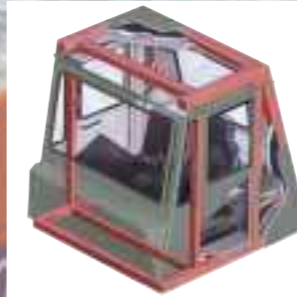

Fully Hydraulic Brake

The fully hydraulic brake features high reliability, durability and serviceability. Optimum brake force yields maximum available braking under tough ground conditions for best control.

Three-point Lubrication

Lubricating points are centralized at the front (left/right) and rear for ease of maintenance.



Ease of Operation

Technological Innovations Improve Handling



Precise Braking Control

Unique variable front to rear brake proportioning maximizes stop performance under slippery road conditions. Front axle brakes are dry disc, rear axle brakes are oil-cooled wet disc.



Rugged, Low-Noise Cab

The Command Cab III uses double-wall construction and a 3-point rubber iso-mount to absorb shocks and noise. User-friendly controls and air conditioning enhance operator comfort.



Electronic Hoist Control

The electronic hoist control reduces operator effort when the body is raised and lowered. This decreases operator fatigue and increases productivity.



Front Axle Trailing Arm Design with NEOCON™ Suspension

The independent front axle trailing arm coupled with NEOCON suspension cylinders reduces suspension-induced frame twisting while providing independent tire action.

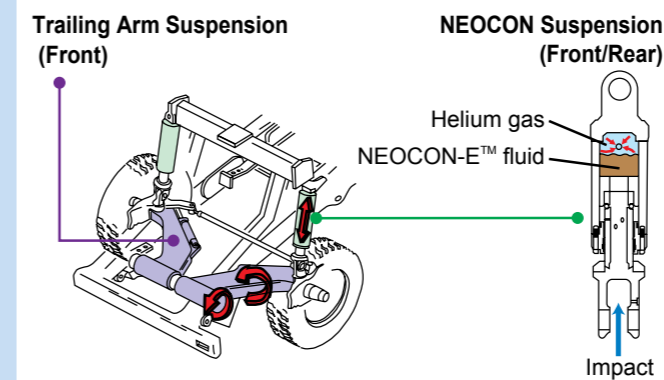
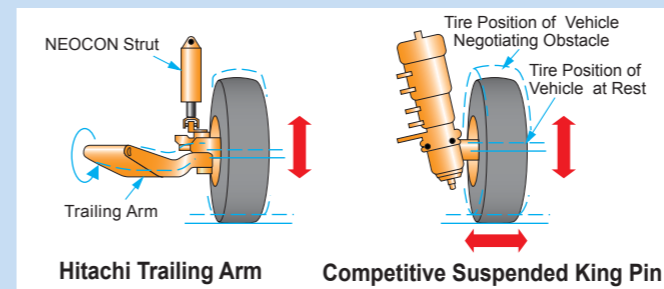

Automatic Transmission

The combination of CEC2 and the new Shift Energy management (SEM) system enables the transmission to control speed and torque conditions during upshifts as well as shifts from Neutral to First or Neutral to reverse.

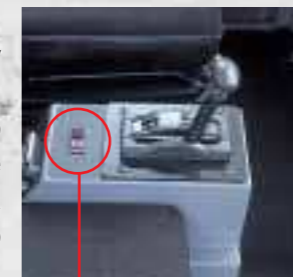

Load-and-Dump Brake

The load-and-dump brake is applied at the touch of a switch locking the rear brakes at full pressure. This feature should be used during loading and dumping operations.

Hill-Hold Brake (Optional)

The hill-hold brake is automatically activated when the operator releases the throttle pedal while climbing a grade. The brake remains applied until the engine RPM reaches 1 200 rpm. This system eliminates unit roll-back while on grades.



Foot-Operated Retarder

With the foot-operated retarder brake, the operator can keep his/her eyes on the road and both hands on the steering wheel. This air-less system provides consistent performance and faster response time while increasing reliability and reducing downtime.



Precise Handling

A combination of a simple steering geometry, front trailing arm suspension, and a low-center of gravity enables the EH1700 to take turns at faster speeds than other rigid haulers in the industry, increasing productivity.



Specifications: EH1700



ENGINE

Model	Cummins QST 30
Type	4 Cycle
Aspiration	Turbocharged/Aftercooled
Rated Power @2 100 min ⁻¹ (rpm)	
Gross power (SAE J1995)	895 kW (1 200 HP)
Net power (SAE J1349)	836 kW (1 121 HP)
Maximum Torque @1 400 min ⁻¹ (rpm)	5 084 N·m (518 kgf·m, 3 750 lbf·ft)
Bore & Stroke	140 x 165 mm (5.51 in x 6.50 in)
Displacement	30.5 L (1 861 in ³)
Starting	Electric



TRANSMISSION

Allison M9600A, planetary type, full automatic shift. Integral torque converter with automatic lock-up shifting in all ranges. Remote mounted, 6 forward speeds, 2 reverse. Allison Commercial Electronic Control provides park brake interlock and hoist interlock as well as built-in diagnostics.

Maximum Speeds @ Governed Engine Speed with standard 31/80R49()E4 tires and 22.88:1 total reduction.**

Gear	Ratio	31/80R49(**)E4 km/h (mph)	27.00R49(**)E4 km/h (mph)
1	4.24	10.5 (6.5)	10.9 (6.8)
2	3.05	14.5 (9.0)	15.3 (9.5)
3	2.32	19.2 (11.9)	20.0 (12.4)
4	1.67	26.6 (16.5)	27.8 (17.3)
5	1.00	44.3 (27.5)	46.3 (28.8)
6	0.72	61.6 (38.3)	64.5 (40.1)
R1	5.75	7.7 (4.8)	8.0 (5.0)
R2	4.13	10.8 (6.7)	11.3 (7.0)



DRIVE AXLE

Power is transferred to wheels through a Hitachi model 2657 differential with an externally removable pinion seal and roller bearing open differential. Full floating axle shafts drive the Hitachi model 1080 heavy duty planetaries in each wheel. The parallel link mounting with an "A-frame" top member reduces "roll-steer" effect.

Ratios	Standard	Optional
Differential	2.86:1	3.15:1
Planetary	8.00:1	8.00:1
Total Reduction	22.88:1	25.20:1

Maximum Speed		
with 31/80R49(**)E4 Tires	61.6 km/h	(38.3 mph)
with 27.00R49(**)E4 Tires	64.5 km/h	(40.0 mph)



TIRES

Standard – Front and Rear	Rim Width
31/80R49(**)E4 Radial Michelin	559 mm (22.0 in)
Optional – Front and Rear	
27.00R49(**)E4 Radial	495 mm (19.5 in)

Certain job conditions may require higher TKPH (TMPH) in order to maintain maximum production. Hitachi recommends evaluating the job conditions and consult the tire manufacturer to make proper tire selection. Optional rims available.



ELECTRICAL SYSTEM

Twenty-four volt lighting and accessories system. 100-ampere alternator with integral transistorized voltage regulator. Two 1150-ampere, cold cranking, 12-volt, maintenance-free, heavy-duty batteries connected in series/parallel. Standard CONTRONIC II monitoring and central warning system with built-in diagnostics and a standard Liquid Crystal Display (LCD) in the cab.



BODY CAPACITY

	m ³ (yd ³)
Struck (SAE)	38.6 (50.5)
Heap 3:1	53.4 (69.9)
Heap 2:1 (SAE)	60.3 (78.8)

This body is for 31/80R49(**)E4 tires use only. Body capacity and payload subject to change based on customer specific material density and application.



WEIGHTS

	kg	(lb)
Chassis with Hoist	57 085	(125 850)
Body	14 651	(32 300)
Net Machine Weight	71 736	(158 150)
Front Axle	34 315	(75 650)
Rear Axle	37 421	(82 500)

Maximum GMW with Std. Tires 170 100 (375 000)
[31/80R49(**)E4]
Including Options, 50% Fuel, Operator & Payload Not to Exceed.

Payload with Standard Equipment 98.4 tonnes (108 tons)

Note:Nominal Payload on front cover shows 90 % of Payload with Standard Equipment

Load Weight Distribution	FRONT	REAR
	33 %	67 %

Major Options	kg	(lb)
Approximate change in Net Machine Weight:		
Body Liners, Complete	4 030	(8 884)



STEERING SYSTEM

Closed-center, full-time hydrostatic power steering system using two double-acting cylinders, pressure limit compensated piston pump with unload control feature, and a brake actuation/steering system reservoir. An accumulator provides supplementary steering in accordance with SAE J1511/ISO 5010. Tilt/telescopic steering wheel with 35° of tilt and 57.15 mm (2.25") telescopic travel is standard.

Steering Angle	38°
Turning Diameter (SAE)	21.8 m (71'6")
Steering Pump Output (@ 2100 min ⁻¹ (rpm))	158.1 L/min (41.8 gpm)
System Pressure	19.0 MPa (2 750 psi)



HYDRAULIC SYSTEM

Two (2) Hitachi two-stage cylinders, double-acting in second stage, internal dampened (extend and retract) inverted and outboard-mounted. Separate hoist/brake cooling reservoir and independent tandem gear pump. Electronically operated control valve. Hoist lever can be mounted on left or right of seat. Equipped with body up speed restriction.

Body Raise Time	12.8 s
Body Down Time	12.1 s
Brake Cooling Pump Output (@ 2 100 min ⁻¹ (rpm))	469.4 L/min (124.0 gpm)
Hoist Pump Output Total (@ 2 100 min ⁻¹ (rpm))	469.4 L/min (124.0 gpm)
System Relief Pressure	20.3 MPa (2 950 psi)
Total Brake Cooling Flow	939.8 L/min (248.0 gpm)



BRAKE SYSTEM

Brake systems meet or surpass SAE J1473/ISO 3450.

The Hitachi EH1700 is equipped with an all-hydraulic actuated braking system providing precise braking control and quick system response. The brake control valve is actuated directly at the brake pedal. The controller has a unique variable front to rear brake proportioning that maximizes the stopping performance under slippery road conditions and accounts for weight transfer without having to deactivate front brakes.

Service
Service brakes are all hydraulically actuated. Front disc brakes have two calipers per disc that are internally ported, each containing three pairs of opposing pistons. Rear brakes are oil-cooled wet disc type.

Front Axle – Dry Disc		
Disc Diameter Each (2 discs/axle)	400 mm	(101.6 in)
Brake Surface Area Per Axle	14 194 cm ²	(2 200 in ²)
Lining Area Per Axle	4 129 cm ²	(640 in ²)
Brake Pressure (Max.)	19.0 MPa	(2 750 psi)

Rear Axle – Oil-Cooled Wet Disc		
Brake Swept Area Per Axle	7.93 m ²	(12 288 in ²)
Brake Pressure (Max.)	13.8 MPa	(2 000 psi)

Secondary
Two independent circuits within the service brake system provide back-up stopping capability. System is manually or automatically applied to stop machine within prescribed braking distance.

Parking
Dry disc mounted on differential input shaft. Controlled by a toggle switch on the dash or automatically applied if brake hydraulic pressure is lost.

Size (Diameter)	685.8 mm (27 in)
-----------------	------------------

Retarder
Foot-operated valve controls all-hydraulic actuation of oil-cooled wet disc brakes on rear axle. System provides constant speed control on downhill hauls.

Capacity		
Continuous	1 051 kW	(1 410 HP)
Intermittent	1 820 kW	(2 440 HP)

Load/Dump Brake Apply
Through activation of a switch by the operator, a solenoid is energized, sending full brake pressure to apply the rear Wet Disc brakes. For use during the load and dump cycles.



WET DISC BRAKE

The Hitachi wet disc brake is engineered for long service life even in the most extreme environments. The wet disc brakes are located on the rear axle and provide service braking, secondary braking and retarding. The brakes are of a multi-plate design and continuously oil-cooled. The sealed design protects against environmental contamination for prolonged service life. The wet disc brake is designed with automatic retraction and self-adjusting features to prevent drag and compensate for wear. Separate pedals activate the service braking and retarding functions to help the operator keep both hands on the steering wheel.



COMMAND CAB III

Command Cab III
ROPS complies with ISO3471 and SAE J1040. FOPS complies with ISO3449. Double wall construction of 11 gauge inner and outer steel panels, lends itself to a more structurally sound cab. Foam rubber lining material along with foam rubber-backed carpeting and multiple layered floor mat act to absorb sound and control interior temperature. A properly maintained cab from Hitachi, tested with doors and windows closed per work cycle procedures in SAE J1166, results in an operator sound exposure Leq (Equivalent Sound Level) of 80 dB(A). A three-point rubber isomount arrangement to the deck surface minimizes vibration to the operator compartment.

Excellent Serviceability
A removable front panel allows easy access to service brake valves, retarder valve and heater assembly. The upper dash utilizes four (4) removable panels that house gauges and customer options, each individually accessible. A removable panel located behind the seat provides easy access to the shifting control, CONTRONIC II, and all electrical junction points.

Comfort and Ease of Operation
A wrap-around style dashboard positions controls within easy reach and visual contact. A full complement of easy-to-read gauges, CONTRONIC II monitoring and warning system with Liquid Crystal Display (LCD), a spacious environment, six-way adjustable mechanical seat, tilt/ telescopic steering wheel, filtered ventilation, door locks, and a padded trainer seat, all contribute to operator convenience and comfort.

Equipment & Dimensions: EH1700



SUSPENSION

Front Suspension

Independent trailing arm for each front wheel. NEOCON struts containing energy-absorbing gas and environmentally friendly compressible NEOCON-E™ fluid mounted between trailing arm and frame.

Rear Suspension

The cast rear axle housing has a parallel link mounting with an A-Frame top member. This provides a reduced "roll-steer" effect which results in a more stabilized ride and contributes to lower overall frame stress levels. Outboard-mounted NEOCON struts suspend drive axle from frame. NEOCON struts provide variable damping and rebound feature.

The unique trailing arm front suspension absorbs haul road input, minimizing suspension-induced frame twisting while providing independent tire action. Ride struts are mounted with spherical bushings, eliminating extreme sidewall forces by ensuring a purely axial input to the ride strut. The wide track stance of the trailing arm design and long wheel base assure a more stable, comfortable ride. The suspension struts employ gas and NEOCON-E™ fluid as the energy-absorbing media. This suspension continues to absorb energy when extreme dynamic loads are generated which significantly contributes to improved isolation of the operator and machine components.

The Hitachi frame and suspension are designed to work in unison to provide maximum structural integrity and operator comfort. The formed rectangular frame rail construction provides superior resistance to bending and torsional loads while eliminating unnecessary weight. Hitachi achieves long frame fatigue life through proven design and manufacturing practices. Smooth frame transitions minimize stress concentrations and steel castings effectively distribute input loads. Frame life is further enhanced by utilizing fatigue-resistant weld joints and locating welds in low stress areas.



FRAME

Formed rectangular rails with section height tapered from rear to front, bridged by five cross members, front bumper and front suspension tube. Cross member to frame junctions use large radii to minimize stress. Frame utilizes 345 MPa (50 000 psi) yield strength steel.



BODY

Flat chute type, sloped floor, continuously exhaust heated. High tensile strength 400 BHN abrasion resistant alloy steel is used in thickness of:

	mm	(in)
Floor	17	(0.67)
Front	8	(0.31)
Sides	8	(0.31)
Canopy	5	(0.20)
Corner	11	(0.43)

Optional Body Liners (Regular Duty)		
Floor, Corners & Top Rails	10	(0.39)
Sides, Front, End Protection	6	(0.24)

Optional Body Liners (Heavy Duty)		
Floor & Corners	16	(0.63)
Top Rails	10	(0.39)
Sides, Front & End Protection	8	(0.31)
Canopy	6	(0.24)

The horizontal stiffener design of the Hitachi body minimizes stress concentrations in any one area. Load shocks are dissipated over the entire body length. The closely-spaced floor stiffeners provide additional protection by minimizing distances between unsupported areas.



SERVICE CAPACITIES

	L	(US gal)
Accumulator	37.9	(10.0)
Crankcase (incl. filters)	143.0	(38.0)
Transmission (incl. filters)	98.4	(26.0)
Cooling System	276.0	(73.0)
Fuel Tank	1 003.0	(265.0)
Hydraulic		
Hoist System	318.0	(84.0)
Steering System	117.0	(31.0)
Differential	147.6	(39.0)
Planetaries (both sides)	174.1	(46.0)
Windshield washer	7.6	(2.0)

STANDARD EQUIPMENT

GENERAL

- Air conditioning
- All-hydraulic braking
- Automatic transmission shifting
- Battery disconnect switch
- Body down indicator, mechanical
- Body prop cable
- Body up and down cushioning
- Body up speed restriction w/light
- Canopy spill guard
- Continuous heated body
- Cooling system surge tank
- Dagger clamps (rear wheels)
- Driveline guard, front
- Dual cab access ladders (shown in Dimensions only)
- Electric horns
- Electronic hoist control
- Electric start
- Engine belt protection
- Fan guard
- Fenders
- Fixed steering stops
- Front brake cut-off switch
- Fuel tank sight gauge
- Guard rails
- HID headlights

CAB

- Acoustical lining
- Air filtration/replaceable element
- Ash tray
- Cab interior light
- Cigar lighter, 12-volt
- Door locks
- Foot rest (left and right)
- Heater and defroster 7.6 kW 26 000 btu
- Integral ROPS/FOPS cab
- ISO driver envelope
- Liquid Crystal Display* (CONTRONIC II)
- Clutch pressure
- Distance traveled
- Engine oil pressure
- Fuel gauge
- Gear selection
- Integrated transmission diagnostics
- Load counter

GAUGES AND INDICATORS

- CONTRONIC II monitoring and alarm system, multi-function indicator lights:
- Air filter restriction
- Alternator
- Body up
- Brake pressure
- Central warning
- Converter temperature
- Cooling temperature
- Do not shift
- Engine oil pressure
- High beam indicator
- Hydraulic filter
- Parking brake applied
- Retard oil temperature
- Steering filter
- Steering pressure
- Steering temperature
- Transmission filter
- Transmission oil pressure
- Turn signals/hazard
- Transmission malfunction

MACHINE LIGHTS

- Back-up lights, (2)
- Clearance lights (LED), (4)
- Dual combination stop and taillights (LED), (2)
- HID Headlights, (4)
- Turn signals and four-way flashers

- Hoist interlock
- Hoist tank sight gauges
- ISO decals
- LED taillights
- Load/dump brake
- Mirrors (front)
- Mirrors right and left, hand adjustable
- Mud flaps-extended
- NEOCON suspension struts
- Park brake, dry disc
- Park brake interlock
- Radiator grill guard
- Radiator, premium core
- Radiator shutters, engine ECM controlled
- Reverse alarm
- Rock ejector bars
- Steering accumulator
- Steering tank sight gauge
- Tires 31/80R49(**)E4
- Tow points, front
- Transmission guard
- Transmission sight gauge
- Water to oil transmission cooler
- Wet disc brake wear indicators

- Service intervals, job site adjustable
- Total engine hours
- Total idle hours
- Voltmeter
- Modular instrumentation
- Quick connect test ports
- Roll down windows
- Rubber floor mat
- Safety glass
- Seat belts, retractable (operator and trainer)
- Seat, mechanical 6 position
- Sun visor
- Tilt/telescopic steering wheel
- Tinted glass all windows
- Trainer seat
- Windshield washer
- Windshield wiper, intermittent
- 12-volt 50 amp circuit
- 12-volt accessory connection

Gauges:

- Brake temperature
- Converter temperature
- Coolant temperature
- Hourmeter (LCD)
- Speedometer
- Steering/brake pressure
- Tachomete

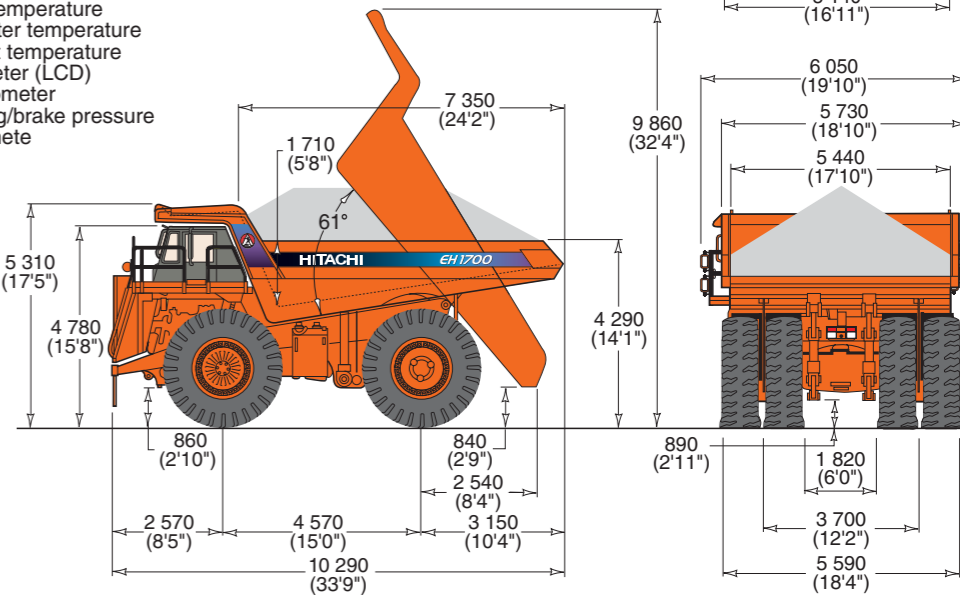

Performance Data: EH1700

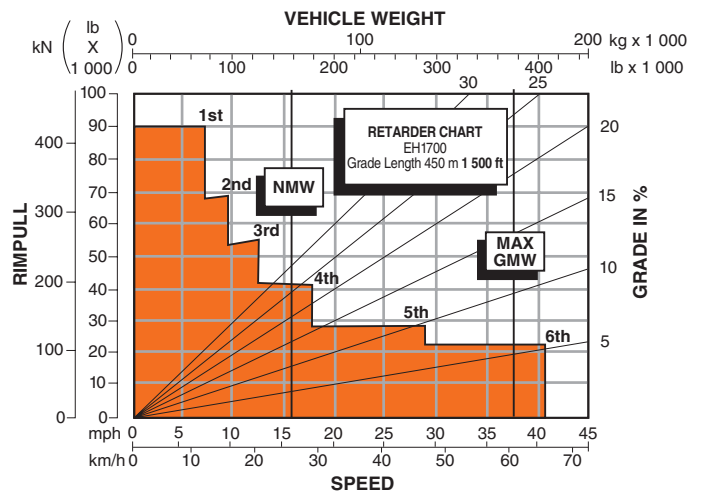
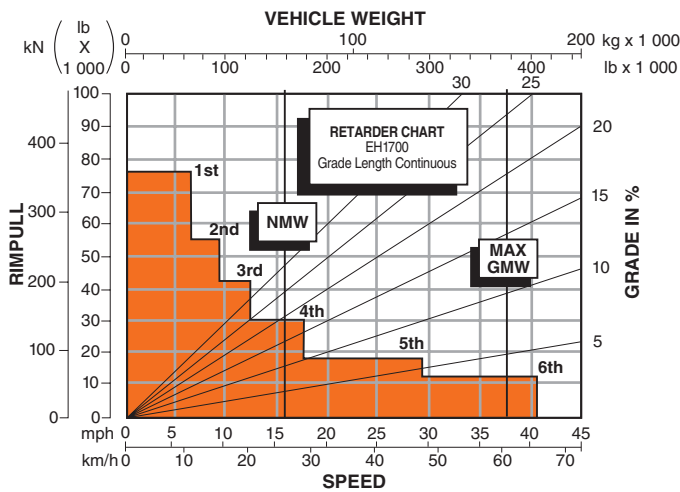
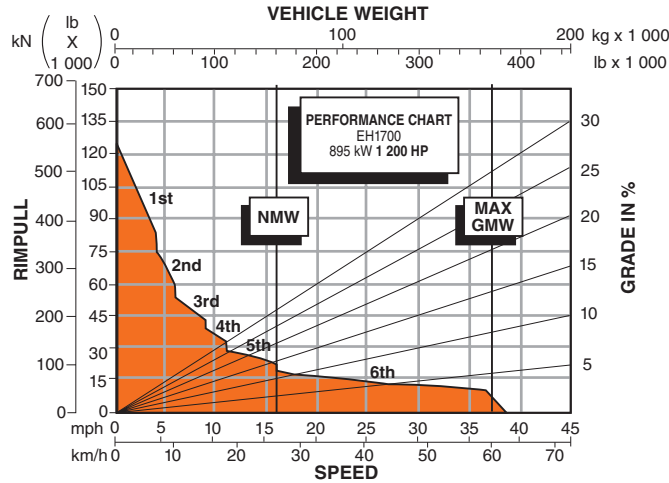

NOTE:

Diagonal lines represent total resistance (Grade % plus rolling resistance %). Charts based on 0% rolling resistance, standard tires and gearing unless otherwise stated.

1. Find the total resistance on diagonal lines on right-hand border of performance or retarder chart.
2. Follow the diagonal line downward and intersect the NMW or GMW weight line.
3. From intersection, read horizontally right or left to intersect the performance or retarder curve.
4. Read down for machine speed.

These specifications are subject to change without notice.

Illustrations and photos show the standard models, and may or may not include optional equipment, accessories, and all standard equipment.

Before use, read and understand Operator's Manual for proper operation.

Hitachi Construction Machinery Co., Ltd.

Head Office : 5-1, Koraku 2-chome, Bunkyo-ku

Tokyo 112-8563, Japan

Telephone : 81-3-3830-8050

Facsimile : 81-3-3830-8204

URL : www.hitachi-c-m.com