



## STANDARD EQUIPMENT FOR BASE MACHINE

### ENGINE:

- AISS (Automatic Idling Setting System)
- Alternator, 90A/24V
- Batteries, 2 x 12V/200Ah
- Engine, Komatsu SAA6D170E-5
- Mode selection system
- Starting motor, 2 x 7.5 kW

### CAB:

- Ashtray
- Cigarette lighter
- Cup holder
- Electronic hoist control system
- Electronic maintenance display/monitoring system
- Operator seat, reclining, suspension type with retractable 78 mm 3" width seat belt
- Passenger seat
- Power window (L.H.)
- ROPS cab with FOPS, sound suppression type
- Space for lunch box
- Steering wheel, tilt and telescopic
- Sunvisor
- Laminated glass, front
- Two doors, left and right

- Windshield washer and wiper (with intermittent feature)

### LIGHTING SYSTEM:

- Back-up light
- Hazard lights
- Headlights with dimmer switch
- Indicator, stop and tail lights

### GUARD AND COVERS:

- Exhaust thermal guard
- Fire protective covers
- Drive shaft guard (front and rear)

### SAFETY EQUIPMENT:

- Alarm, backup
- ARSC (Automatic Retard Speed Control)
- Coolant temperature alarm and light
- Front brake cut-off system
- Hand rails for platform
- Horn, electric
- Ladders, left and right hand sides
- Overrun warning system
- Rearview mirrors and under view mirrors
- Supplementary steering

### OTHER:

- Centralized greasing
- Electric circuit breaker, 24V
- Mud guards

### BODY:

- Body exhaust heating
- Cab guard, left side
- Spill guard, 150mm 6"

### TIRES:

- 24.00 R35



## OPTIONAL EQUIPMENT

### CAB:

- Air conditioner
- Heater and defroster
- Operator seat, air suspension type
- Radio, AM/FM with cassette
- Seat belt, 78 mm 3" width for passenger seat
- Sunvisor, additional
- Power window (R.H.)

### BODY:

- Body liner
- Platform guard, right hand side
- Without body heating (with muffler)

### LIGHTING SYSTEM:

- Back work lights, left and right sides
- Fog lights
- Yellow beacon

### SAFETY:

- ABS (Antilock Brake System)
- ASR (Automatic Spin Regulator)
- Automatic supplementary steering
- Rear view camera and monitor

### ARRANGEMENT:

- Batteries for cold area arrangement
- Cold area arrangement
- Sandy and dusty area arrangement

### OTHER:

- Autogreasing system
- Engine coolant heater
- Engine oilpan heater
- Engine side cover
- Engine underguard
- Fire extinguisher
- Fuel quick charge
- Payload meter II

### MUFFLER:

- Muffler (no body heating type)
- Radiator shutter, canvas type
- Spare parts for first service
- Three-mode hydropneumatic suspension
- Tool kit
- Transmission underguard
- Vandalism protection
- VHMS (Vehicle Health Monitoring System)
- VHMS with satellite communication kit

### TIRES:

- 24.00-35-36PR

Standard equipment may vary for each country, and this specification sheet may contain attachments and optional equipment that are not available in your area. Please consult your Komatsu distributor for detailed information.

[www.Komatsu.com](http://www.Komatsu.com)

Printed in Japan 200603 IP.P.AD

**KOMATSU**<sup>®</sup>

CEN00095-00

Materials and specifications are subject to change without notice  
**KOMATSU** is a trademark of Komatsu Ltd. Japan

**KOMATSU**<sup>®</sup>

**HD605-7E0**  
Quarry

**GROSS HORSEPOWER**

551 kW 739 HP

**NET HORSEPOWER**

533 kW 715 HP

**MAXIMUM GVW**

110180 kg 242,900 lb

**ecot3**

**HD  
605**



Photo may include optional equipment.

**OFF-HIGHWAY TRUCK**



# WALK-AROUND

## Productivity Features

- High performance Komatsu SAA6D170E-5 engine  
Net horsepower **533kW** 715HP
- Mode selection system  
(Variable horsepower at Economy mode)
- Automatic idling setting system (AISS)
- Automatic retard speed control (ARSC)
- 7-speed, fully automatic K-ATOMiCS transmission
- Fully hydraulic controlled wet multiple-disc brakes and retarder  
Retarder absorbing capacity (Continuous descent) **785kW** 1,052HP
- Long wheelbase and wide tread
- Large high strength body  
Heaped capacity **40.0m<sup>3</sup>** 52.3yd<sup>3</sup>
- Small turning radius **8.5m** 27'11"
- PLM II (Paylord meter II)(Option)

## Harmony with Environment

- Komatsu SAA6D170E-5 engine  
North American EPA Tier 3 and EU stage 3A emission certified for 2006
- Low operation noise
- Lead-free radiator
- Brake cooling oil recovery tank

## Operator Environment

- Wide, spacious cab with excellent visibility
- Ergonomically designed cab
- Easy-to-see instrument panel
- Ideal driving position settings
- K-ATOMiCS with "Skip-shift" function
- Hydropneumatic suspension
- Built-in ROPS/FOPS
- Viscous cab mounts
- Electric body dump control lever
- Supplementary steering and secondary brakes
- Three-mode hydropneumatic suspension  
(Automatic suspension) (Option)



Photo may include optional equipment.

## Reliability Features

- Komatsu components
- High-rigidity frame
- Rigorous dump body design
- Reliable hydraulic system
- Flat face-to-face O-ring seals
- Sealed DT connectors
- ABS(Antilock brake system)(Option)
- ASR(Automatic spin regulator)(Option)
- Pedal-operated secondary brake

## Easy Maintenance

- Advanced monitoring system
- Wet multiple-disk brakes and fully hydraulic braking system
- Extended oil change interval
- Centralized arrangement of filters
- Flange type rim
- Electric circuit breaker
- Centralized greasing points
- Vehicle health monitoring system (VHMS) (Option)

**GALEO**  
Genuine Answers for Land & Environment  
Optimization

# PRODUCTIVITY FEATURES

## Komatsu technology



Komatsu develops and produces all major components, such as engines, electronics and hydraulic components, in house.

With this "Komatsu Technology," and adding customer feedback, Komatsu is achieving greater advancements in technology.

To achieve both high levels of productivity and economical performance, Komatsu has developed the main components with a total control system.

The result is a new generation of high performance and environment friendly machines.

## High performance Komatsu SAA6D170E-5 engine

This engine delivers faster acceleration and higher travel speeds with high horsepower per ton. Advanced technology, such as Common Rail Injection system (CRI), air to air aftercooler, efficient turbo-charger, and heavy duty cooled EGR enables the engine to be North American EPA Tier 3 and EU stage 3A emission certified. High torque at low speed, impressive acceleration, and low fuel consumption ensure maximum productivity.

## Mode selection system

The system allows selection of the appropriate mode between two modes <Power mode > or <Economy mode> according to each working condition. The mode is easily selected with a switch in the operator's cab.

### Power mode

Great productivity can be attained by taking full advantage of high output power. It is appropriate for job sites where larger production uphill-hauling is required.

### Economy mode (Variable horsepower)

The engine power automatically changes depending on loaded or unloaded conditions always to use an optimum speed gear. It is appropriate for light work on flat ground.

## Automatic Idling Setting System (AISS)

This system facilitates quick engine warm-up and cab cooling/warming. When setting the system ON, engine idle speed is kept at 945 rpm when coolant temperature is 50°C 122°F or lower. Speed automatically returns to 750 rpm when coolant temperature reaches 50°C 122°F.



## 7-speed, fully automatic K-ATOMiCS transmission

The K-ATOMiCS (Komatsu Advanced Transmission with Optimum Modulation Control System) automatically selects the optimum gear according to vehicle speed, engine speed and the shift position you've chosen. The result: the best gear for any driving situation.



K-ATOMiCS (Komatsu Advanced Transmission with Optimum Modulation Control System)

## Automatic Retard Speed Control (ARSC)

ARSC allows the operator to simply set the downhill travel speed and go down slopes at a constant speed. As a result, the operator can concentrate on steering. The speed can be set at increments of 1 km/h 0.6 MPH per click (±5 km/h 3.1 MPH of maximum speed adjustment) to match the optimum speed for the slope. Also, since the retarder cooling oil temperature is always monitored, the speed is automatically lowered.

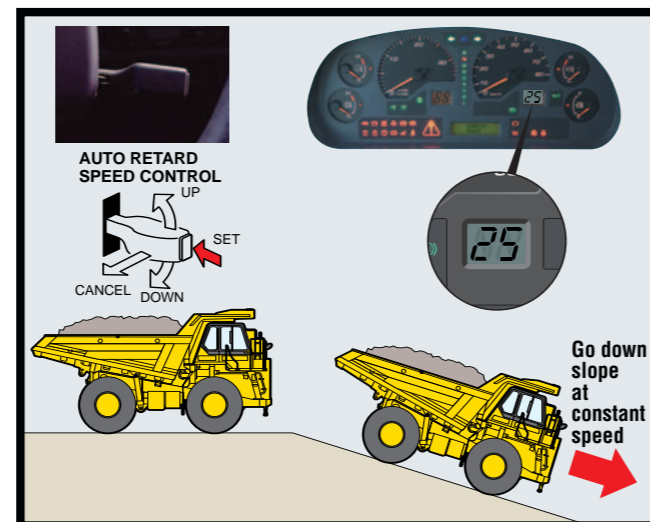

## Fully hydraulic controlled wet multiple-disc brakes and retarder

Wet multiple-disc brakes ensure highly reliable and stable brake performance. The large-capacity, continuously cooled, wet-multiple disc brakes also function as a highly responsive retarder which gives the operator greater confidence at higher speeds when traveling downhill.

- Retarder Absorbing Capacity (continuous descent): **785 kW** 1,052 HP
- Brake Surface Area (rear): **64,230 cm<sup>2</sup>** 9,956 in<sup>2</sup>

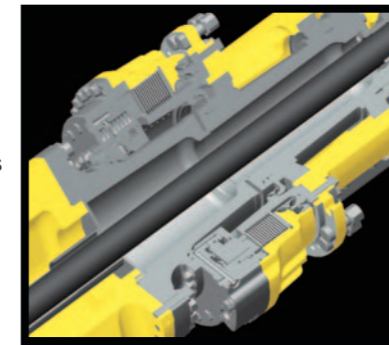

## Long wheelbase and wide tread

With an extra-long wheelbase, a wide tread and an exceptionally low center of gravity, the HD605-7 hauls the load at higher speed for more production, and delivers superior driving comfort over rough terrain.

## Large high strength body

A wide target area makes for easy loading with minimal soil spillage and more efficient hauling. The body is built of **160 kg/mm<sup>2</sup>** 227,520 PSI wear-resistant high-tensile steel with a Brinell hardness of 500. The V-shape design also increases structural strength, and provides excellent load stability.

## Small turning radius

The MacPherson strut type front suspension has a special A-frame between each wheel and the main frame. The wider space created between the front wheels and the main frame increases the turning angle of the wheels. The larger this turning angle, the smaller the turning radius of the truck.

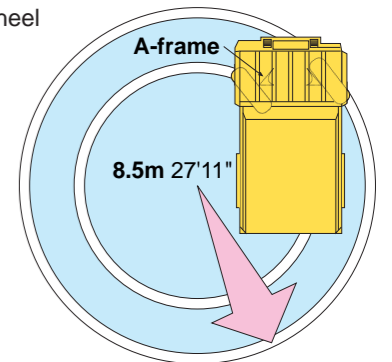

## PLM II (Payload Meter II) (Option)

PLM II allows the production volume and the working conditions on the dump truck to be analyzed and controlled directly via a personal computer. The system can store up to 2900 working cycles.

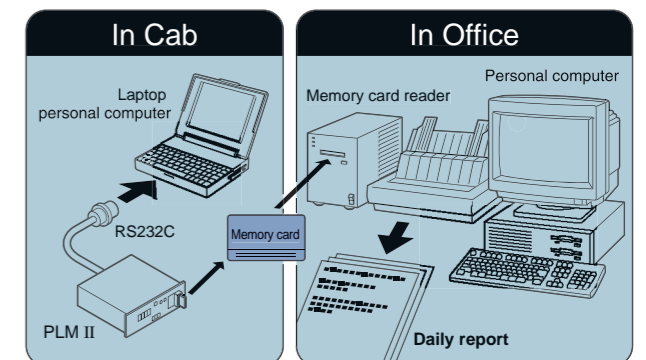

Note) The memory card, card reader and software for data processing are available as options.



# OPERATOR ENVIRONMENT

## Wide, spacious cab with excellent visibility

Wide windows in the front, side and back, plus plenty of space in the richly upholstered interior, provide quiet, comfortable environment from which to see and control every aspect of operation. Front under view mirrors and side under view mirrors have been added to improve safety.

## Ergonomically designed cab

The ergonomically designed operator's compartment makes it very easy and comfortable for the operator to use all the controls. The result is more confident operation and greater productivity.

## Easy-to-see instrument panel

The instrument panel makes it easy to monitor critical machine functions. In addition, a caution light warns the operator of any problems that may occur. Problems are recorded in the monitor and indicated as service codes. This makes the machine very friendly and easy to service.

## Ideal driving position settings

The 5-way adjustable operator seat and the tilt-telescopic steering column create an optimum driving posture, for increased driving comfort and more control over the machine's operations. The suspension seat dampens vibrations transmitted from the machine and reduces operator fatigue as well as holding the operator securely to assure confident operation. 78mm 3" width seat belt is provided as standard equipment.



## Hydropneumatic suspension for all terrains

The hydropneumatic suspension assures a comfortable ride even over rough terrain and ensures maximum productivity and operator confidence.

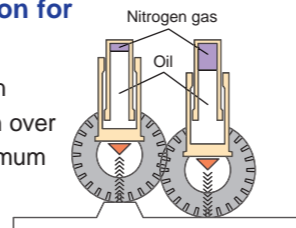

## K-ATOMiCS with "Skip-shift" function

An electronically controlled valve is provided for each clutch pack in the transmission for independent clutch engagement/disengagement. It enables an ideal change in clutch modulation pressure and torque cut-off timing in response to travel conditions. This system and newly added "skip-shift" function ensure smooth shifting and responsive acceleration.

## "Skip-shift" function

Optimum travel speed automatically selected in response to angle of ascent. Reduced frequency of downshift and smoother operation are provided.

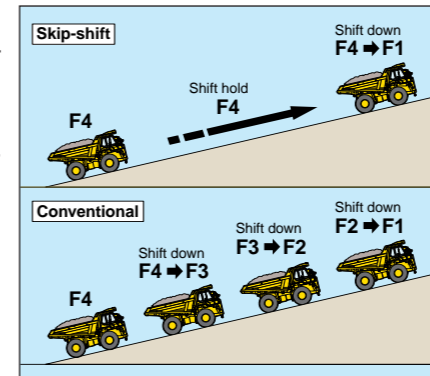

## Three-mode hydropneumatic suspension (Automatic suspension) (Option)

Suspension mode is automatically switched to one of three stages (soft, medium and hard) according to load and operating conditions, for a more comfortable and stable ride.

## Built-in ROPS/FOPS

These structures conform to ISO3471 and SAE J1040 ROPS standards, and ISO 3449 and SAE J231 FOPS standards.



## Viscous cab mounts

Viscous mounts reduce the noise transmitted to the cab and achieve a quiet 77 dB(A) noise level.

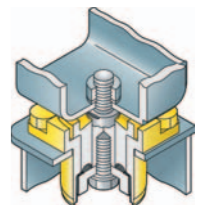

## Electric body dump control lever

The low effort lever makes dumping easy. A positioning sensor is installed for dump body control which significantly reduces the shock made by the lowering of the dump body.



## Supplementary steering and secondary brakes

Supplementary steering and secondary brakes are standard features.

Steering: ISO 5010, SAE J1511, SAE J53

Brakes: ISO 3450, SAE J1473



# RELIABILITY FEATURES

## Komatsu components

Komatsu manufactures the engine, torque converter, transmission, hydraulic units, and electrical parts on this dump truck. Komatsu dump trucks are manufactured with an integrated production system under a strict quality control system.

## High-rigidity frame

Cast-steel components are used in the main frame for high-stress areas where loads and shocks are most concentrated.



## Rigorous dump body design

The standard dump body is made of 160 kg/mm<sup>2</sup> 227,520 PSI high-tensile-strength steel for excellent rigidity and reduced maintenance cost. The V-shape and V-bottom design also increase structural strength. The side and bottom plates of the dump section are reinforced with ribs for added strength.

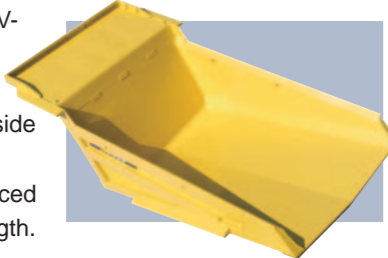

## Reliable hydraulic system

The oil cooler is installed in the radiator lower tank, improving the reliability of the hydraulic system during sudden temperature rises. Further, in addition to the main filter, a 25-micron line filter is at the entrance to the transmission control valve. This system helps to prevent secondary faults.

## Flat face-to-face O-ring seals

Flat face-to-face O-ring seals are used to securely seal all hydraulic hose connections and to prevent oil leakage.

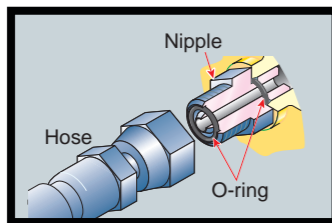

## Protection functions supported by electronic control

Item	Function
Downshift inhibitor	Even if the driver downshifts accidentally, a speed appropriate to the current gear is automatically set, preventing over-runs.
Over-run inhibitor	When descending grades, if the vehicle's speed surpasses the maximum for the current gear, the rear brakes automatically operate, preventing over-runs.
Reverse inhibitor	The vehicle is prevented from moving backward when operating the body.
Forward/Reverse shift inhibitor	This device makes it impossible to shift from forward to reverse when the vehicle's speed surpasses 4 km/hour.
Anti-hunting system	When running near a shift point, smooth automatic shifting takes place.
Neutral safety	The engine is prevented from starting when the shift lever is not in neutral.

## Sealed DT connectors

Main harnesses and controller connectors are equipped with sealed DT connectors providing high reliability, water resistance and dust resistance.



## ABS (Antilock braking system) (Option)

Using its outstanding electronics technology, Komatsu is the first in the industry to introduce ABS on construction machinery. This system prevents the tires from locking, thus minimizing skidding under slippery conditions while applying the service brake.

## ASR (Automatic spin regulator) (Option)

ASR automatically prevents the rear tires on either side from slipping on soft ground for optimal traction.

## Pedal-operated secondary brake

If there should be a failure in the foot brake, the parking brake and front disc brakes are activated as pedal operated secondary brake. In addition, when hydraulic pressure drops below the rated level, the parking brake is automatically actuated.



## Lead-free radiator

In addition to compliance with emission regulations, a lead-free aluminum core is adopted for the radiator to comply with global environmental requirements.

## Brake cooling oil recovery tank

To protect environment, a tank is installed to recover brake cooling oil in the event of brake floating seal leakage.

# EASY MAINTENANCE

## Advanced monitoring system

The Komatsu advanced monitoring system identifies maintenance items, reduces diagnostic times, indicates oil and filter replacement hours and displays abnormality codes. This monitor system helps to maximize machine production time.



## Wet multi-disc brakes and fully hydraulic braking systems

mean lower maintenance costs and higher reliability. Wet disc brakes are fully sealed to keep contaminants out, reducing wear and maintenance. Brakes require no adjustments for wear, meaning even lower maintenance. The parking brake is also an adjustment-free, wet multiple-disc system for high reliability and long life. Added reliability is designed into the braking system by the use of three independent hydraulic circuits providing hydraulic backup should one of the circuits fail. Fully hydraulic braking systems eliminate the air system so air bleeding is not required, and water condensation that can lead to contamination, corrosion and freezing is eliminated.

## Extended oil change intervals

In order to minimize operating costs, oil change intervals have been extended:

- Engine oil 500 hours
- Hydraulic oil 4000 hours

## Centralized arrangement of filters

The filters are centralized so that they can be serviced easily.

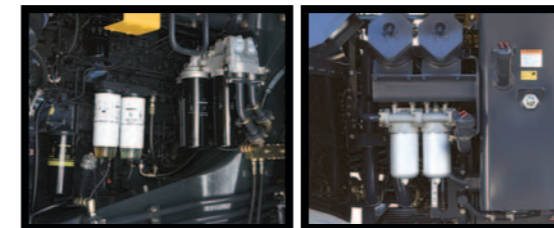

## Flange type rim



Flange type rims provide easy removal/installation for the tires.

## Electric circuit breaker

A circuit breaker is adopted in important electric circuits that should be restored in a short time when a problem occurs in the electrical system.



## Centralized greasing points

Greasing points are centralized at three locations.



## VHMS (Vehicle Health Monitoring System) (Option)

VHMS controller monitors the health conditions of major components, enables remote analysis of the machine and its operation. This process is supported by the Komatsu distributors, factory and design team. This contributes to reduced repair costs and to maintaining maximum availability.

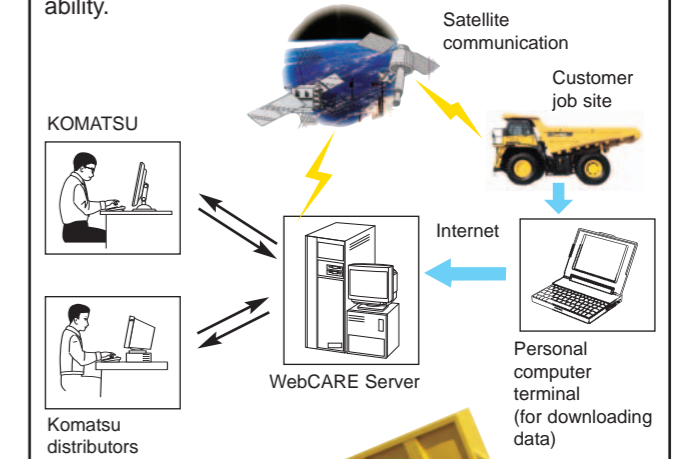

# SPECIFICATIONS



## ENGINE

Model..... Komatsu SAA6D170E-5  
 Type..... Water-cooled, 4-cycle  
 Aspiration..... Turbo-charged, air-to-air after-cooled, cooled EGR  
 Number of cylinders..... 6  
 Bore x stroke..... **170 mm x 170 mm** 6.69" x 6.69"  
 Piston displacement..... **23.15 ltr** 1,413 in<sup>3</sup>  
 Horsepower:  
 SAE J1995..... Gross **551 kW** 739 HP  
 ISO9249/SAE J1349..... Net **533 kW** 715 HP  
 Rated rpm..... 2000 rpm  
 Fan drive type..... Mechanical  
 Maximum torque..... **339 kg•m** 2,452 lb. ft  
 Fuel system..... Direct injection  
 Governor..... Electronically controlled  
 Lubrication system  
 Method..... Gear pump, force-lubrication  
 Filter..... Full-flow type  
 Air cleaner..... Dry type with double elements and precleaner (cyclonpack type), plus dust indicator



## TRANSMISSION

Torque converter..... 3-elements, 1-stage, 2-phase  
 Transmission..... Full-automatic, planetary type  
 Speed range..... 7 speeds forward and 1 reverse  
 Lockup clutch..... Wet, multiple-disc clutch  
 Forward..... Torque converter drive in 1st gear, direct drive in 1st lockup and all higher gears  
 Reverse..... Torque converter drive  
 Shift control..... Electronic shift control with automatic clutch modulation in all gears  
 Maximum travel speed..... **70.0 km/h** 43.5 mph



## AXLES

Rear Axle..... Full-floating  
 Final drive type..... Planetary gear  
 Ratios:  
 Differential..... 3.538  
 Planetary..... 4.737



## SUSPENSION SYSTEM

Independent, hydropneumatic suspension cylinder with fixed throttle to dampen vibration.  
 Effective cylinder stroke (front suspension)..... **303 mm** 11.9"  
 Rear axle oscillation:  
 Oil stopper..... 6.8°  
 Mechanical stopper..... 7.7°



## STEERING SYSTEM

Type..... Fully hydraulic power steering with two double-acting cylinders  
 Supplementary steering..... Manual control (meets ISO 5010, SAE J1511 and SAE J53)  
 Minimum turning radius..... **8.5 m** 27'11"  
 Maximum steering angle..... 39°



## CAB

Dimensions comply with ISO 3471 and SAE J1040-1988c ROPS (Roll-Over Protective Structure) standards.



## MAIN FRAME

Type..... Box-sectioned structure



## BRAKES

Brakes meet ISO 3450 and SAE 1473 standards.  
 Service brakes:  
 Front..... Fully hydraulic control, caliper disc type  
 Rear..... Fully hydraulic control, oil-cooled multiple-disc type  
 Parking brake..... Spring applied, multiple-disc type  
 Retarder..... Oil-cooled, multiple-disc rear brakes act as retarder.  
 Secondary brake..... Manual pedal operation.  
 When hydraulic pressure drops below the rated level, parking brake is automatically actuated.

Brake surface  
 Front..... **1936 cm<sup>2</sup>** 300 in<sup>2</sup>  
 Rear..... **64230 cm<sup>2</sup>** 9,956 in<sup>2</sup>



## BODY

Capacity:  
 Struck..... **29.0 m<sup>3</sup>** 37.9 yd<sup>3</sup>  
 Heaped (2:1, SAE)..... **40.0 m<sup>3</sup>** 52.3 yd<sup>3</sup>  
 Payload..... **63.0 metric tons** 69.4 U.S. tons  
 Material..... **160 kg/mm<sup>2</sup>** 227,520 psi high tensile strength steel  
 Structure..... V-shape body with V-bottom  
 Material thickness:  
 Bottom..... **25 mm** 0.98"  
 Front..... **16 mm** 0.63"  
 Sides..... **14 mm** 0.55"  
 Target area  
 (inside length x width)..... **6600 mm x 3870 mm** 21'8" x 12'8"  
 Dumping angle..... 48°  
 Height at full dump..... **8800 mm** 28'10"  
 Heating..... Exhaust heating



## HYDRAULIC SYSTEM

Hoist cylinder..... Twin, 2-stage telescopic type  
 Relief pressure..... **20.6 MPa** 210 kg/cm<sup>2</sup> 2,990 psi  
 Hoist time..... 11.5 sec



## WEIGHT (APPROXIMATE)

Empty weight..... **46200 kg** 101,850 lb  
 Max. gross vehicle weight..... **110180 kg** 242,900 lb  
 Not to exceed max. gross vehicle weight, including options, fuel and payload.  
 Weight distribution:  
 Empty: Front axle..... 47%  
 Rear axle..... 53%  
 Loaded: Front axle..... 32%  
 Rear axle..... 68%



## TIRES

Standard tire..... 24.00 R35



## SERVICE REFILL CAPACITIES

Fuel tank..... **780 ltr.** 206.1 U.S. Gal  
 Engine oil..... **80 ltr.** 21.1 U.S. Gal  
 Torque converter, transmission and retarder cooling..... **215 ltr.** 56.8 U.S. Gal  
 Differential..... **95 ltr.** 25.1 U.S. Gal  
 Final drives (total)..... **42 ltr.** 11.1 U.S. Gal  
 Hydraulic system..... **122 ltr.** 32.2 U.S. Gal  
 Suspension (total)..... **55.6 ltr.** 14.7 U.S. Gal



## DIMENSIONS

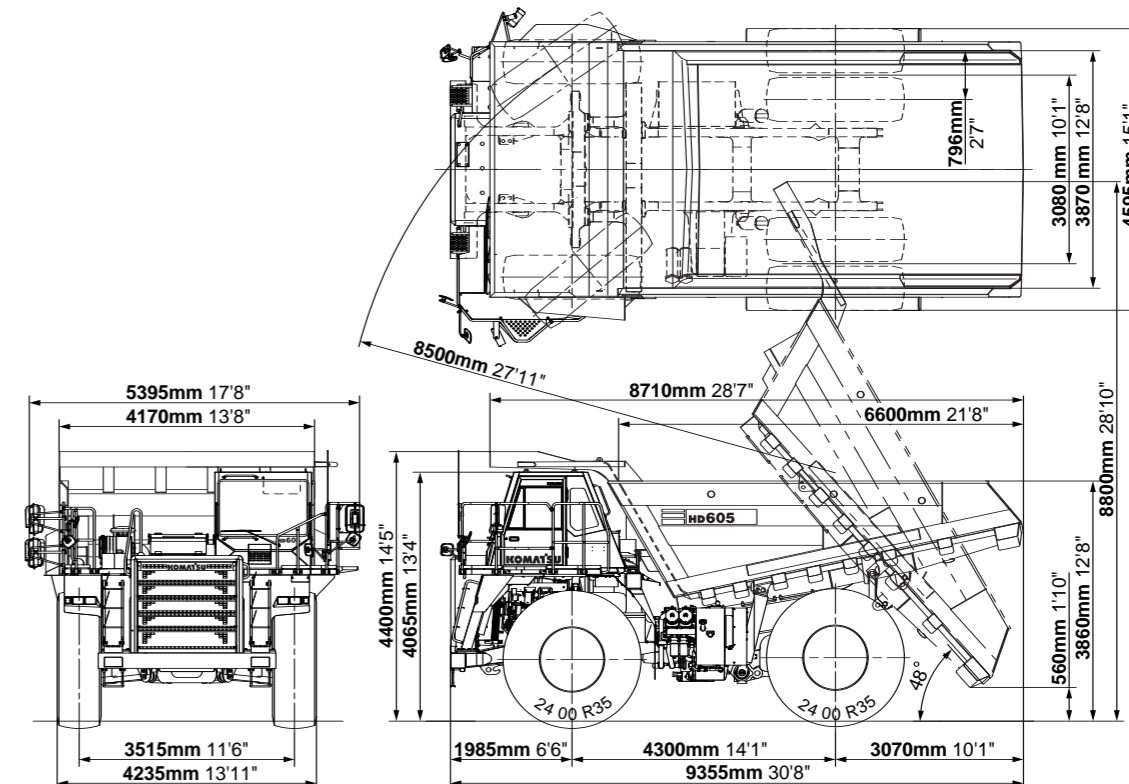

## TRAVEL PERFORMANCE

To determine travel performance: Read from gross weight down to the percent of total resistance. From this weight-resistance point, read horizontally to the curve with the highest obtainable speed range, then down to maximum speed. Usable rimpull depends upon traction available and weight on drive wheels.

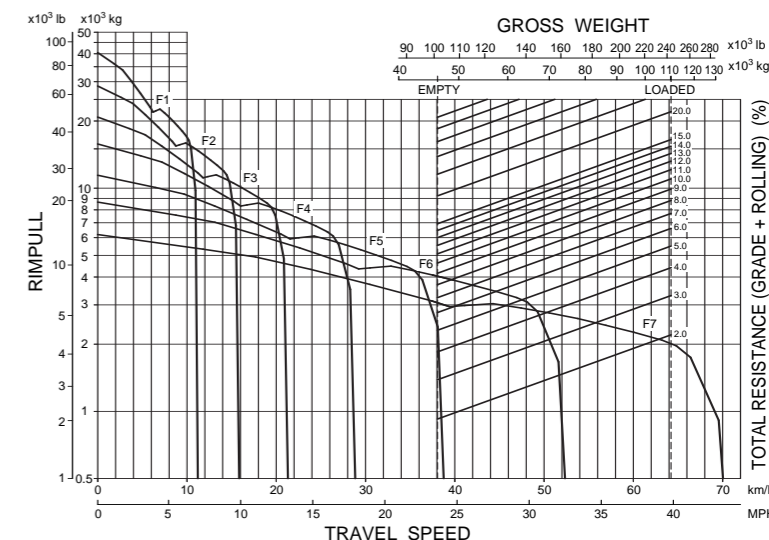

## BRAKE PERFORMANCE

To determine brake performance: These curves are provided to establish the maximum speed and gearshift position for safer descents on roads with a given distance. Read from gross weight down to the percent of total resistance. From this weight-resistance point, read horizontally to the curve with the highest obtainable speed range, then down to maximum descent speed the brakes can safely handle without exceeding cooling capacity.

### Grade distance: Continuous descent

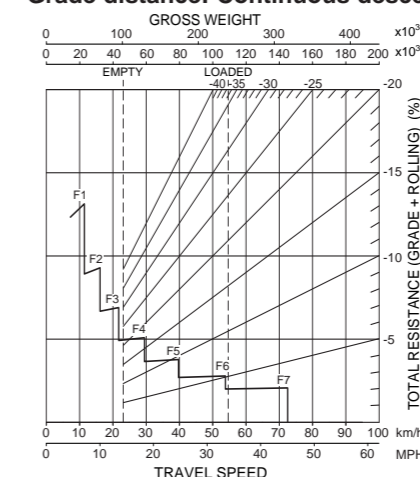

### Grade distance: 450 m (1480 ft)

