

E-series

Articulated Dump Trucks

B18E | B20E | B25E | B30E MK2



BELL

E is for evolution

Your business is our business. Bell Articulated Dump Trucks haul more, for longer at the lowest cost-per-ton to deliver more on your profit margins.

As a global leader in Articulated Dump Trucks, Bell Equipment brings you the world class E-series range. The evolutionary E-series is packed with class leading features that deliver production boosting payloads, lower daily operating costs, superior ride quality and uncompromised safety standards. Bell E-series ADTs will give your business the competitive edge you need.



Specifications	B18E	B20E	B25E	B30E
Gross power	160 kW (214 hp)	160 kW (214 hp)	205 kW (275 hp)	240 kW (322 hp)
Operating mass				
Empty	15 110 kg (33 312 lb)	15 260 kg (33 643 lb)	18 910 kg (41 689 lb)	19 310 kg (42 571 lb)
Loaded	33 110 kg (72 995 lb)	33 260 kg (73 326 lb)	42 910 kg (94 600 lb)	47 310 kg (104 301 lb)
Rated payload	18 000 kg (39 683 lb)	18 000 kg (39 683 lb)	24 000 kg (52 911 lb)	28 000 kg (61 729 lb)
2:1 heaped capacity	11 m ³ (14,5 yd ³)	11 m ³ (14,5 yd ³)	15 m ³ (19,5 yd ³)	17,5 m ³ (22,9 yd ³)



- Extensive use of high-strength, lightweight materials give these trucks the best payload-to-mass ratios and hauling efficiencies in each class.

- With their oscillating frame and high-floatation tyres, Bell trucks won't leave you stuck on muddy, rutted or hilly terrain.

- The redesigned sound-suppressed cab features fatigue-beating controls, advanced diagnostic monitor and a sealed-switch module for convenient, fingertip operation of numerous functions.

- Fuel-efficient emission-certified engines deliver clean power without compromise in all conditions. Leading-edge emissions technology ensures rapid engine response and dependable cold-start performance.

The new E-series range takes ADT functionality to new industry standards, with customer-focused enhancements and the highest level of automated machine protection available.

Through substantial investments in Research and Development and employing industry leading technology, advancements have been made in the key areas of performance and fuel efficiency – helping you to move more material at lower operating costs and environmental impact.

Building on pedigree

Building on from the D-series platform, Bell Equipment's evolutionary approach to design delivers optimised power-to-weight ratio and legendary fuel efficiency.

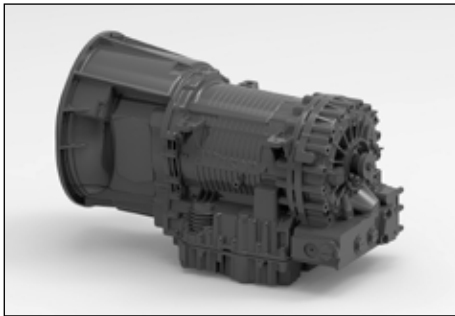

Planetary powershift transmission optimises shift points to match conditions and vehicle weight while protecting the transmission from operator error and abuse.



The transfer case inter-axle differential delivers equal torque to each axle when traction is favourable. When conditions deteriorate, the diff-lock automatically engages to deliver torque to the tyres that can best use it.



High-strength steel and widely spaced taper roller bearings in the articulation area enhance long-term durability.



A tailgate is available as an option for better material retention. The tailgate opens as the bin is raised for dumping. Spring steel straps maintain positive seal throughout the haul, ensuring minimal material is lost.



- Limited slip differentials and electronically controlled automatic Inter-axle Differential Lock (IDL) provide Automatic Traction Control (ATC) in poor underfoot conditions.
- The best-in-class payload-to-weight ratio means that more of your fuel cost is spent moving the material, not running the machine, decreasing your cost per tonne.

- An industry leading, fully automatic six-speed planetary transmission with torque converter lock-up maximises fuel efficiency.
- Automatic retardation slows the truck when the operator backs off the accelerator pedal for more confidence on steep grades and enhanced brake life.

- Electronic unit injection fuel system provides high injection pressures even at low engine speed for improved cold-starting ability, low-speed response and reduced emissions.
- The short front end provides the best approach angle that allows these ADTs to attack steep terrain.
- High-travel suspension keeps all tyres in constant contact with the ground, for optimum traction.

gree

- Improved payloads, faster haul cycles and industry leading fuel economy all help you move more material at a lower-cost-per-tonne than your competitors.

- Class leading payload-to-weight ratio means that more of your fuel cost is spent moving the material and not running the machine - for maximum productivity and profitability.

- With a high oscillating frame joint, articulated steering, and high-floatation tyres, these hard working haulers won't let wet weather or steep grades dampen your plans.



Our innovative front and rear comfort ride suspension options are offered to even further enhance ride quality and ensure minimal whole body vibration exposure.

Productivity increases through reduced cycle times, and reduced haul road maintenance are even further benefits of these extremely successful systems. Experienced ADT operators who have driven trucks installed with these systems have come away amazed by the comfort of the machine, as well as the confidence that the adaptive front suspension engenders.

Uncompromised durability

Built smarter, to work harder. Bell ADTs offer optimised machine weights so you spend more time and money moving material and not running the machine.

With decades of ADT experience, the new Bell E-series articulated hauler is designed and manufactured using purpose built, reliable Bell components best suited for the toughest of conditions. The central oscillation joint, high suspension travel on all axles, and balanced weight distribution provide the agility and ability to navigate hostile terrain.



The high-strength steel chassis delivers strength and rigidity without excess weight.



For comfortable productivity the A-frame suspension system coupled with hydropneumatic suspension struts reduce the lateral vibration often experienced with off-road conditions. A superior suspension seat provides additional isolation for the operator.



Rough terrain demands tough suspensions. Heavy-duty components absorb shocks and come back for more. You get best-in-class suspension travel and ground clearance, too.



- Dual circuit hydraulically actuated dry disc brakes deliver consistent “on-the-mark” braking, even in cold weather. Simplified design makes them easy to maintain.
- Viscous electronically controlled direct-drive engine fans provide cooling for the best efficiency.
- Class leading engine braking coupled with automated transmission retardation, provides superior braking power and reduces service brake wear.

Other uptime-boosting features include world class on-board diagnostics with live stream functionality, solid-state sealed switches and satellite fleet management system.

High-strength welded-alloy steel chassis and reinforced articulation joints, offer superior strength and durability with optimised weight for class leading power-to-weight ratio. Lower machine mass reduces powertrain and structural stress.

Operate with ease

Using the latest in automotive technology and state-of-the-art tooling, the E-series takes operator experience to new heights.

Climb into the cab of a Bell ADT and you will feel right at home. Its quiet, spacious interior, ergonomically positioned operator station and climate-controlled cabin is loaded with productivity-boosting comfort and convenience features that minimise operator fatigue and enhance the operator's experience. Modern flowing lines, in keeping with current styling trends on road vehicles, offer unsurpassed levels of visibility.

From the state-of-the-art 10" full colour screen automotive mouse interface and sealed switch module to air suspension seat, tilt/telescoping steering wheel and optional CD player with high-output speakers, the E-series provides everything your operators need to perform at their best.



Easy-to-understand instruments and intuitive controls wrap around the operator so they're easier to view and operate.



A user friendly 10" colour monitor offers vital operating information, safety warnings, detailed diagnostic readings and dump body function settings.



An automotive controller provides menu navigation on the colour monitor to extract information on machine operation and adjustment of machine settings.



Convenient sealed switch module provides fingertip control of numerous productivity enhancing functions including: **Keyless Start, I-Tip, Dump Body Upper Limit, Soft Stop/Hard Stop Selection, Retarder Aggressiveness and Speed Control.**

- The standard sound-suppression package significantly reduces noise levels and operator fatigue.
- The adaptive transmission control adjusts clutch engagement to ensure smooth, consistent shifts throughout the life of the truck.
- A fully adjustable air-suspension seat with variable damping, auto height adjust according to operator weight, pneumatic lumbar support and multipoint harness for class-leading comfort and safety.
- A purpose designed HVAC climate-control system with automotive-style louvres keeps the glass clear and the cab comfortable.
- New machine styling and cabin design improvements, which include full glass access door and high visibility mirror package, provide exceptional all-round visibility.
- You won't find retarder pedals or levers in a Bell truck. Retarder aggressiveness is simply set on the switch pad. Everything else is automatic.

Safety, our business too

By listening to users and delivering on expectations in an ever changing workplace, we provide a truck that leads in application safety with numerous groundbreaking innovations.

Independent features such as Keyless Start, Hill Assist, Bin Tip Prevention, Auto Park Application (APA), Standard Turbo Spin Protection and On-Board Weighing (OBW) are still standard on the E-series. For improved safety and productivity, the E-series has an electronically controlled automatic Inter-axle Differential Lock (IDL) giving the vehicle full Automatic Traction Control (ATC).



Our quiet operator cabins are ROPS/FOPS certified with an air suspension operator seat. The trainer seat has a retractable lap belt while the operator seat has a standard 3 point seat belt. Both have automatically locking retractors.



An optional integrated reverse camera and high visibility mirrors ensure superior all round visibility.



Keyless start, driver identity and access codes ensure no unauthorised operation of your equipment.



- Full handrails (to ISO 2876) can be installed to offer improved safety when performing engine checks.

- The park brake automatically applies when neutral is selected and it is not possible to engage neutral at speed. Torque dependent park brake release (Hill Assist) ensures no roll back on slopes.

- Best-in-class retarder and engine braking automatically applies when the operator lifts his foot off the accelerator. Retarder aggressiveness can be simply adjusted on the sealed switch module ensuring maximum descent control for all conditions.

- All trucks can be set up to automatically sound the horn when starting or switching between forward and reverse.

- Multiple geofencing in challenging site conditions ensures safe machine operation, such as downhill speed control, geofence speed limits and bin restrictions.



The exclusive on-board weighing presents the operator with real time information on the payload while the machine is being loaded. A 'speed restriction' mode can also be activated if the machine is significantly overloaded.



The incorporation of a pitch and roll sensor in the vehicle prevents bin operation if the truck is in an unsafe position.



Both operator or site selectable maximum speed control allows the vehicle to automatically decelerate and apply the retarder to prevent onsite speeding.

Maximise your uptime

The E-series is loaded with features that make it as easy to maintain as it is to operate. Spend less time and expense getting ready for work and more time getting work done.

Easy-to-reach dipsticks, see-through reservoirs, sight gauges and grouped service points make quick work of the daily routine. Quick-change filters, extended engine and hydraulic oil-service intervals lower daily operating costs and provide superior machine uptime. An industry leading 10" colour monitor offers on-board machine diagnostics as well as automated daily service functionality, this coupled with diagnostic test ports help you troubleshoot and make informed maintenance decisions on site.

- Automated daily service checks can be done with ease and comfort from inside the operator station using the 10" colour LCD monitor and sealed display controller.
- The load-sensing hydraulic system was designed with simplicity in mind, while maintaining efficiency. Fewer components for improved reliability and serviceability.
- Extended engine transmission and hydraulic oil-change for increased uptime and lower operating cost.
- Available environmental drains allow quick, no-spill changes.
- Your Bell Service Centre has the parts and backup you need to stay productive and offers a wide variety of preventative maintenance and support programmes to help you control costs.



If something goes wrong, the diagnostic monitor provides service codes and supporting info to help diagnose the problem.



The cab can be tilted in minutes without special tools, for convenient service access to drivetrain components.



An in-cab load centre simplifies fuse replacement. Fewer relays, connectors and harnesses mean higher reliability.



We offer a remote transmission filter option. They make transmission filter replacement a fast and clean task.



See-through fluid reservoirs and sight gauges let you check fluid levels at a glance.



Easily accessible test ports allow technicians to troubleshoot problems more quickly.



The centralised lube bank places difficult-to-reach grease points within reach.



The convenient and easy to understand RSG decal details daily checks and actions (eg: greasing).

Where ever you are...

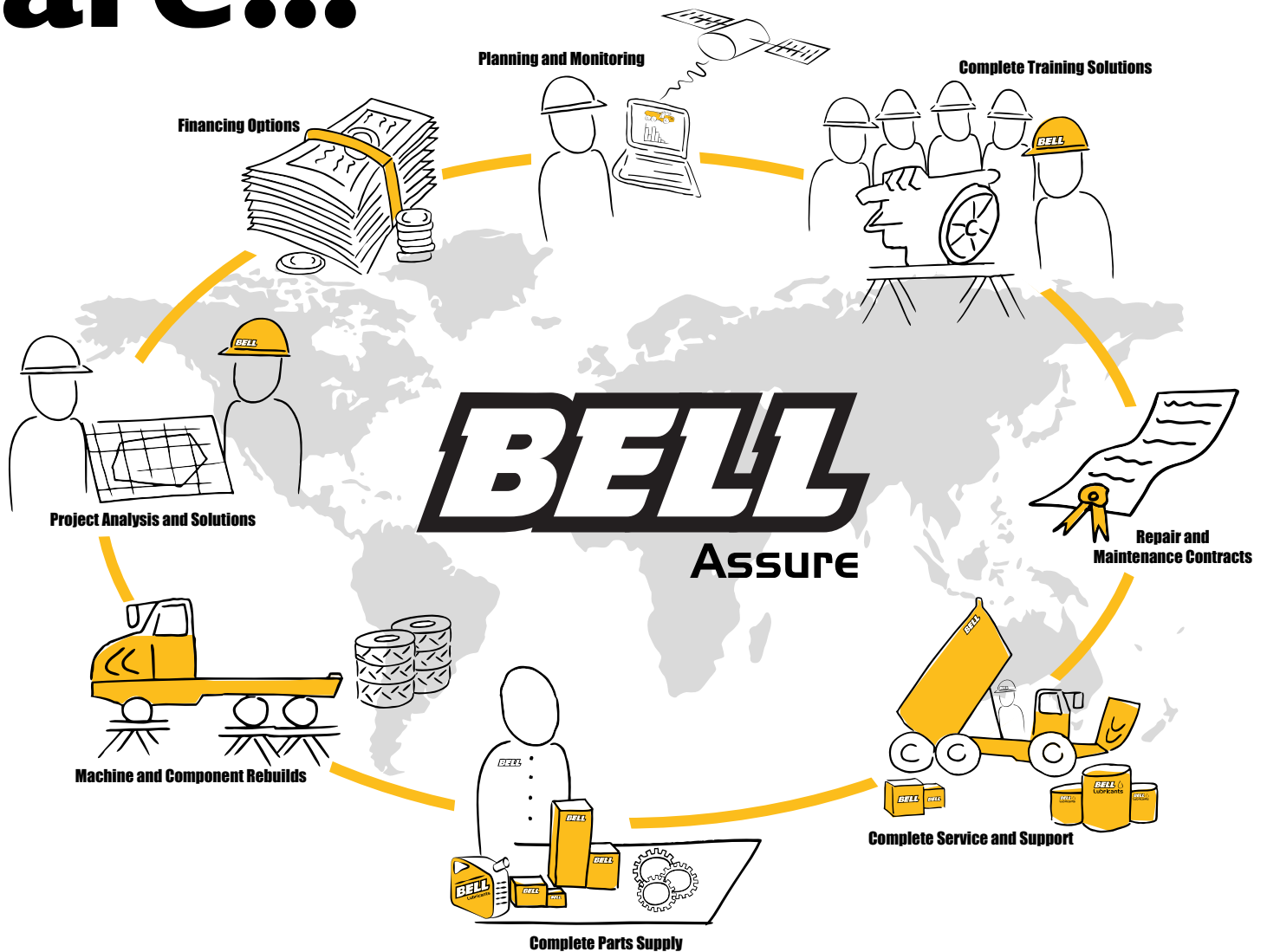

Through our own network as well as approved dealers and strategic alliances we ensure supply and support to the global market.

Develop a lasting and meaningful partnership with Bell Equipment through Bell Assure, your tailor-made support structure furnished with all the after-sales tools you need to give you best value, peace of mind and a unique after-sales experience.

...we have you covered

Smarter fleet management



BELL
Fleetsm@tic

Cutting edge technology, helping you run your fleet smarter. Providing accurate, up-to-date operational data, production data and diagnostic data.

The key to a productive and profitable fleet, lies in the ability to monitor and manage your machines and operators efficiently. Machine operational data is processed and compiled into useful production and performance statistics, accessible via the Bell Fleetsm@tic website. These reports are also automated and emailed directly to you. The two monitoring packages that we have available, are:

- **The Classic Package** supplies you with good enough information for you to have a very good understanding of how your machines is operating for each shift that it runs. This package comes standard with the machine for 2 years.
- **The Premium Package** is focused on customers who need to have extremely detailed information of the machine's operation. For this package we offer similar information to that of the Classic Package but for each individual laden - unladen cycle. In addition, live tracking is available on the Fleetsm@tic website on a per minute basis.

Fleetsm@tic:

- Maximise productivity
- Generate machine utilisation reports
- Identify operator training requirements
- Pro-active maintenance planning
- Receive machine health data
- Implement safety features
- Protect investments
- Receive real time geospatial data

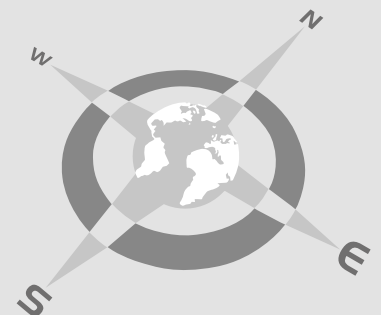

Technical Data - B18E

ENGINE

Manufacturer
Mercedes Benz

Model
OM924LA

Configuration
Inline 4, turbocharged and intercooled.

Gross Power
160 kW (214 hp) @ 2 200 rpm

Net Power
152 kW (204 hp) @ 2 200 rpm

Gross Torque
810 Nm (597 lbf) @ 1 200 -1 600 rpm

Displacement
4,80 litres (293 cu.in)

Auxiliary Brake
Exhaust Valve Brake
Engine Valve Brake

Fuel Tank Capacity
200 litres (53 US gal)

Certification
OM924LA meets Euro III emissions regulations

TRANSMISSION

Manufacturer
Allison

Model
Standard Non Retarder: 3000P ORS
Optional Retarder: 3000PR ORS

Configuration
Fully automatic planetary transmission with integral retarder.

Layout
Engine mounted

Gear layout
Constant meshing planetary gears, clutch operated

Gears
6 Forward, 1 Reverse

Clutch Type
Hydraulically operated multidisc

Control Type
Electronic

Torque Control
Hydrodynamic with lock-up in all gears

TRANSFER CASE

Manufacturer
Bell VGR

Model
8000

Layout
Remote mounted

Gear Layout
Three in-line helical gears

Output Differential
Interaxle 33/67 proportional differential. Automatic inter-axle differential lock.

AXLES

Manufacturer
Bell

Model
15T

Differential
High input limited slip differential with spiral bevel gears.

Final Drive
Outboard heavy duty planetary on all axles

BRAKING SYSTEM

Service Brake
Dual circuit, full hydraulic actuation dry disc brakes with 8 calipers (4F, 2M, 2R).

Maximum brake force:
244 kN (54 720 lbf)

Park & Emergency
Spring applied, air released driveline mounted disc.

Maximum brake force:
182 kN (40 802 lbf)

Auxiliary Brake
Automatic exhaust valve brake and engine valve brake.
Optional automatic, adjustable, integral, hydrodynamic transmission retarder. Output shaft speed dependant.

Total Retardation Power
99kW (133 hp) Continuous non-retarder.
144kW (193 hp) Continuous retarder.
99kW (133 hp) Maximum non-retarder.
505kW (677 hp) Maximum retarder.

WHEELS

Type
Radial Earthmover

Tyre
20.5 R 25

FRONT SUSPENSION

Semi-independent, leading A-frame supported by hydro-pneumatic suspension struts.

REAR SUSPENSION

Pivoting walking beams with laminated rubber suspension blocks

HYDRAULIC SYSTEM

Full load sensing system serving the prioritized steering, body tipping and brake functions. A ground-driven, load sensing emergency steering pump is integrated into the main system.

Pump Type
Variable displacement load sensing piston

Flow
155 l/min (41,5 gal/min)

Pressure
27 MPa (3 915 psi)

Filter
5 microns

STEERING SYSTEM

Double-acting cylinders with ground driven emergency steering pump.

Lock to lock turns
4,32

Steering Angle
45°

DUMPING SYSTEM

Two double-acting, single stage, dump cylinders

Raise Time
10 s

Lowering Time
5,5 s

Tipping Angle
70° standard, or any lower angle programmable

PNEUMATIC SYSTEM

Air drier with heater and integral unloader valve, serving park brake and auxiliary functions.

System Pressure
810 kPa (117 psi)

ELECTRICAL SYSTEM

Voltage
24 V

Battery Type
Two AGM (Absorption Glass Mat) type

Battery Capacity
2 X 75 Ah

Alternator Rating
28 V 80 A

VEHICLE SPEEDS

	km/h	mph
1st	11	7
2nd	20	12
3rd	27	17
4th	38	24
5th	50	31
6th	50	31
R	7	4

CAB

ROPS/FOPS certified 74 dBA internal sound level measured according to ISO 6396.

Load Capacity & Ground Pressure

OPERATING WEIGHTS				GROUND PRESSURE		LOAD CAPACITY		OPTION WEIGHTS	
UNLADEN*		LADEN*		LADEN (No sinkage)		BODY	m ³ (yd ³)		kg (lb)
	Tare kg (lb)**		ISO 6016 kg (lb)***	20.5 R 25	kPa (Psi)	Struck Capacity	9 (11)	Bin liner	811 (1 788)
Front	7 770 (17 130)	Front	9 840 (21 693)	Front	223 (32)	SAE 2:1 Capacity	11 (14,5)	Extra wheelset	355 (783)
Middle	3 760 (8 289)	Middle	11 730 (25 860)	Middle	299 (43)	SAE 1:1 Capacity	13,5 (17,5)		
Rear	3 350 (7 385)	Rear	11 540 (25 441)	Rear	299 (43)	Rated Payload	18 000 kg (39 683 lbs)		
Total	14 870 (32 783)	Total	33 110 (72 995)						
	ISO 6016 kg (lb)***			LADEN (15% sinkage)					
Front	8 040 (17 725)			20.5 R 25	kPa (Psi)				
Middle	3 740 (8 245)			Front	204 (30)				
Rear	3 330 (7 341)			Middle	246 (36)				
Total	15 110 (33 312)			Rear	246 (36)				

* Note that the axle loading quoted is for the lightest configuration of machine. Addition of options will add to this mass. ** No fuel, no operator. *** Full fuel and operator

Dimensions

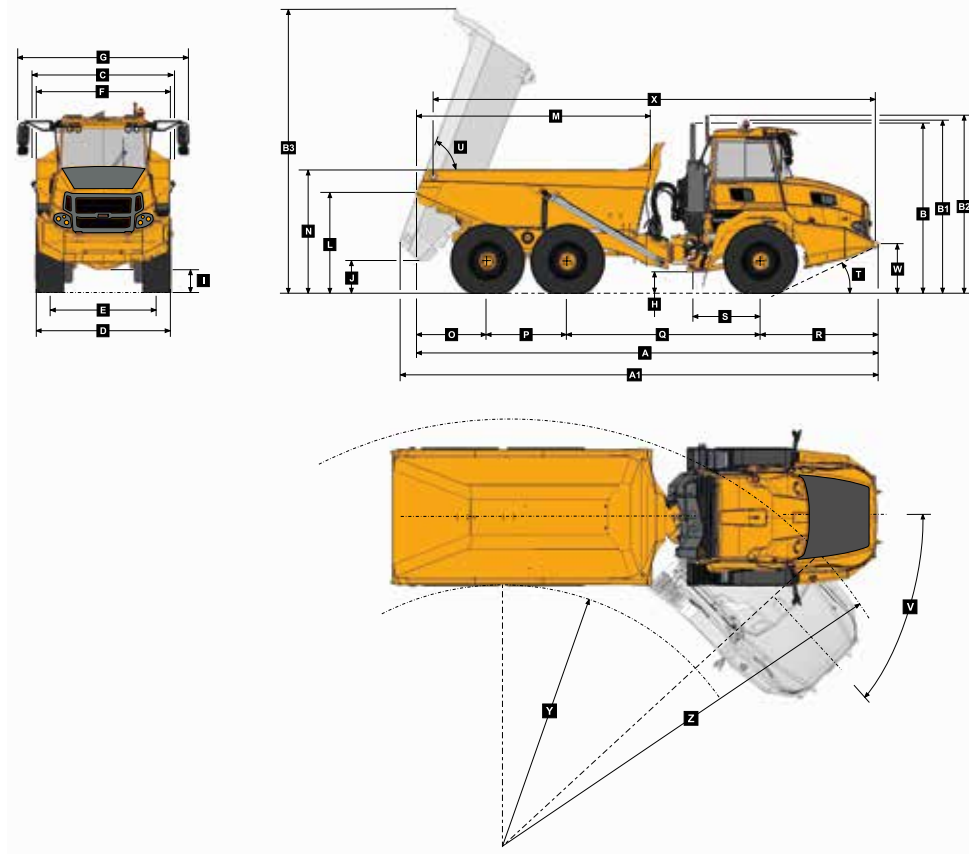

Machine Dimensions

A	Length - Transport Position	9271 mm
A1	Length - Bin Fully Tipped	9573 mm
B	Height - Transport Position	3454 mm
B1	Height - Rotating Beacon	3595 mm
B2	Height - Load Light	3689 mm
B3	Bin Height - Fully Tipped	5743 mm
C	Width over Mudguards	2568 mm
D	Width over Tyres - 20.5R25	2550 mm
E	Tyre Track Width - 20.5R25	2022 mm
F	Width over Bin	2540 mm
G	Width over Mirrors - Operating Position	3260 mm
H	Ground Clearance - Artic	479 mm
I	Ground Clearance - Front Axle	444 mm
J	Ground Clearance - Bin Fully Tipped	704 mm
K	Ground Clearance - Under Run Bar	N/A
L	Bin Lip Height - Transport Position	2060 mm
M	Bin Length	4709 mm
N	Load over Height	2533 mm
O	Rear Axle Centre to Bin Rear	1449 mm
P	Mid Axle Centre to Rear Axle Centre	1600 mm
Q	Mid Axle Centre to Front Axle Centre	3865 mm
R	Front Axle Centre to Machine Front	2357 mm
S	Front Axle Centre to Artic Centre	1361 mm
T	Approach Angle	26 °
U	Maximum Bin Tip Angle	70 °
V	Maximum Articulation Angle	45 °
W	Front Tie Down Height	1028 mm
X	Machine Lifting Centres	8845 mm
Y	Inner Turning Circle Radius - 20.5R25	3954 mm
Z	Outer Turning Circle Radius - 20.5R25	7309 mm

Grade Ability/Rimpull

1. Determine tractive resistance by finding intersection of vehicle mass line and grade line. NOTE: 2% typical rolling resistance is already assumed in chart and grade line.
2. From this intersection, move straight right across charts until line intersects rimpull curve.
3. Read down from this point to determine maximum speed attained at that tractive resistance.

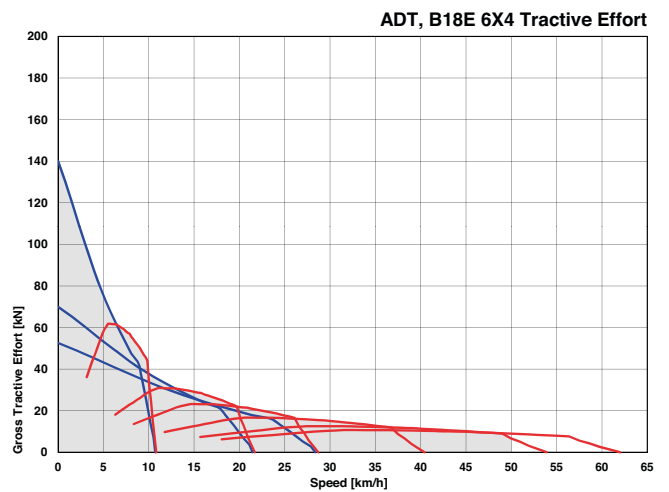
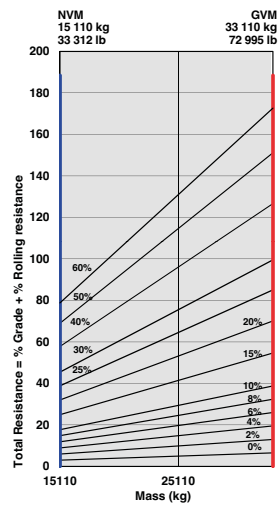

Retardation

1. Determine retardation force required by finding intersection of vehicle mass line.
2. From this intersection, move straight right across charts until line intersects the curve. NOTE: 2% typical rolling resistance is already assumed in chart.
3. Read down from this point to determine maximum speed.

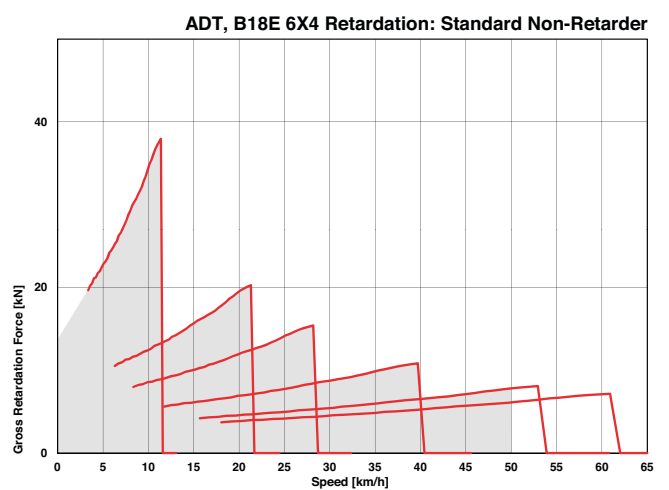
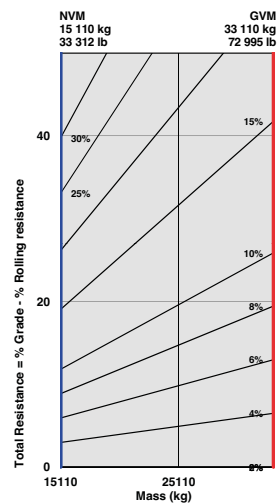

Technical Data - B20E

ENGINE

Manufacturer
Mercedes Benz

Model
OM924LA

Configuration
Inline 4, turbocharged and intercooled.

Gross Power
160 kW (214 hp) @ 2 200 rpm

Net Power
152 kW (204 hp) @ 2 200 rpm

Gross Torque
810 Nm (597 lbf) @ 1 200 -1 600 rpm

Displacement
4,80 litres (293 cu.in)

Auxiliary Brake
Exhaust Valve Brake
Engine Valve Brake

Fuel Tank Capacity
200 litres (53 US gal)

Certification
OM924LA meets Euro III emissions regulations

TRANSMISSION

Manufacturer
Allison

Model
Standard Non Retarder: 3000P ORS
Optional Retarder: 3000PR ORS

Configuration
Fully automatic planetary transmission with integral retarder.

Layout
Engine mounted

Gear layout
Constant meshing planetary gears, clutch operated

Gears
6 Forward, 1 Reverse

Clutch Type
Hydraulically operated multi-disc

Control Type
Electronic

Torque Control
Hydrodynamic with lock-up in all gears

TRANSFER CASE

Manufacturer
Bell VGR

Model
8000

Layout
Remote mounted

Gear Layout
Three in-line helical gears

Output Differential
Interaxle 33/67 proportional differential. Automatic inter-axle differential lock.

AXLES

Manufacturer
Bell

Model
15T

Differential
High input limited slip differential with spiral bevel gears.

Final Drive
Outboard heavy duty planetary on all axles

BRAKING SYSTEM

Service Brake
Dual circuit, full hydraulic actuation dry disc brakes with 8 calipers (4F, 2M, 2R).

Maximum brake force:
244 kN (54 720 lbf)

Park & Emergency
Spring applied, air released driveline mounted disc.

Maximum brake force:
182 kN (40 802 lbf)

Auxiliary Brake
Automatic exhaust valve brake and engine valve brake.
Optional automatic, adjustable, integral, hydrodynamic transmission retarder. Output shaft speed dependant.

Total Retardation Power
99kW (133 hp) Continuous non-retarder.
144kW (193 hp) Continuous retarder.
99kW (133 hp) Maximum non-retarder.
505kW (677 hp) Maximum retarder.

WHEELS

Type
Radial Earthmover

Tyre
20.5 R 25

FRONT SUSPENSION

Semi-independent, leading A-frame supported by hydro-pneumatic suspension struts.

REAR SUSPENSION

Pivoting walking beams with laminated rubber suspension blocks

HYDRAULIC SYSTEM

Full load sensing system serving the prioritized steering, body tipping and brake functions. A ground-driven, load sensing emergency steering pump is integrated into the main system.

Pump Type
Variable displacement load sensing piston

Flow
155 l/min (41,5 gal/min)

Pressure
27 MPa (3 915 psi)

Filter
5 microns

STEERING SYSTEM

Double-acting cylinders with ground driven emergency steering pump.

Lock to lock turns
4,32

Steering Angle
45°

DUMPING SYSTEM

Two double-acting, single stage, dump cylinders

Raise Time
10 s

Lowering Time
5,5 s

Tipping Angle
70° standard, or any lower angle programmable

PNEUMATIC SYSTEM

Air drier with heater and integral unloader valve, serving park brake and auxiliary functions.

System Pressure
810 kPa (117 psi)

ELECTRICAL SYSTEM

Voltage
24 V

Battery Type
Two AGM (Absorption Glass Mat) type

Battery Capacity
2 X 75 Ah

Alternator Rating
28 V 80 A

VEHICLE SPEEDS

1st	11 km/h	7 mph
2nd	20 km/h	12 mph
3rd	27 km/h	17 mph
4th	38 km/h	24 mph
5th	50 km/h	31 mph
6th	50 km/h	31 mph
R	7 km/h	4 mph

CAB

ROPS/FOPS certified 74 dBA internal sound level measured according to ISO 6396.

Load Capacity & Ground Pressure

OPERATING WEIGHTS				GROUND PRESSURE		LOAD CAPACITY		OPTION WEIGHTS	
UNLADEN*		LADEN*		LADEN (No sinkage)		BODY	m ³ (yd ³)		kg (lb)
	Tare kg (lb)**		ISO 6016 kg (lb)***	20.5 R 25	kPa (Psi)	Struck Capacity	9 (11)	Bin liner	493 (1 087)
Front	7 720 (17 020)	Front	9 790 (21 583)	Front	223 (32)	SAE 2:1 Capacity	11 (14,5)	Extra wheelset	355 (783)
Middle	3 860 (8 510)	Middle	11 830 (26 081)	Middle	300 (44)	SAE 1:1 Capacity	13,5 (17,5)		
Rear	3 450 (7 606)	Rear	11 640 (25 662)	Rear	300 (44)				
Total	15 020 (33 113)	Total	33 260 (73 326)			Rated Payload	18 000 kg		
	ISO 6016 kg (lb)***			LADEN (15% sinkage)			(39 683 lbs)		
Front	7 990 (17 615)			20.5 R 25	kPa (Psi)				
Middle	3 840 (8 466)			Front	203 (29)				
Rear	3 430 (7 562)			Middle	248 (36)				
Total	15 260 (33 113)			Rear	248 (36)				

* Note that the axle loading quoted is for the lightest configuration of machine. Addition of options will add to this mass. ** No fuel, no operator. *** Full fuel and operator

Dimensions

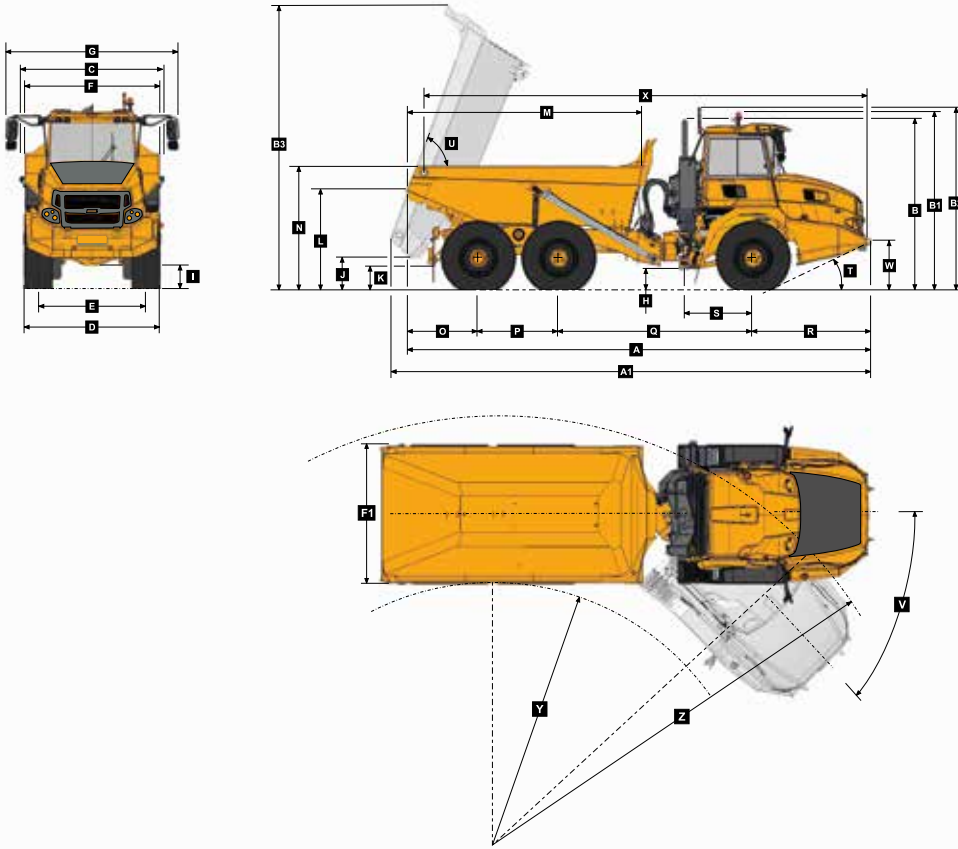

Machine Dimensions

A	Length - Transport Position	9271 mm
A1	Length - Bin Fully Tipped	9573 mm
B	Height - Transport Position	3454 mm
B1	Height - Rotating Beacon	3595 mm
B2	Height - Load Light	3689 mm
B3	Bin Height - Fully Tipped	5743 mm
C	Width over Mudguards	2568 mm
D	Width over Tyres - 20.5R25	2550 mm
E	Tyre Track Width - 20.5R25	2022 mm
F	Width over Bin	2540 mm
F1	Width over Tail Lights	2582 mm
G	Width over Mirrors - Operating Position	3260 mm
H	Ground Clearance - Artic	479 mm
I	Ground Clearance - Front Axle	444 mm
J	Ground Clearance - Bin Fully Tipped	704 mm
K	Ground Clearance - Under Run Bar	535 mm
L	Bin Lip Height - Transport Position	2060 mm
M	Bin Length	4709 mm
N	Load over Height	2533 mm
O	Rear Axle Centre to Bin Rear	1449 mm
P	Mid Axle Centre to Rear Axle Centre	1600 mm
Q	Mid Axle Centre to Front Axle Centre	3865 mm
R	Front Axle Centre to Machine Front	2357 mm
S	Front Axle Centre to Artic Centre	1361 mm
T	Approach Angle	26 °
U	Maximum Bin Tip Angle	70 °
V	Maximum Articulation Angle	45 °
W	Front Tie Down Height	1028 mm
X	Machine Lifting Centres	8845 mm
Y	Inner Turning Circle Radius - 20.5R25	3954 mm
Z	Outer Turning Circle Radius - 20.5R25	7309 mm

Grade Ability/Rimpull

1. Determine tractive resistance by finding intersection of vehicle mass line and grade line. NOTE: 2% typical rolling resistance is already assumed in chart and grade line.
2. From this intersection, move straight right across charts until line intersects rimpull curve.
3. Read down from this point to determine maximum speed attained at that tractive resistance.

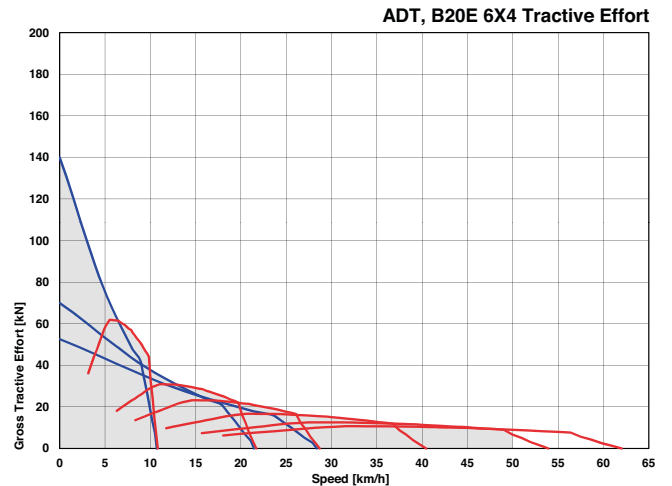
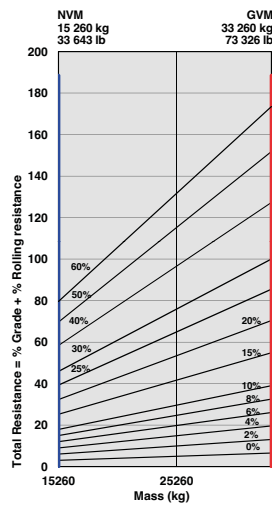

Retardation

1. Determine retardation force required by finding intersection of vehicle mass line.
2. From this intersection, move straight right across charts until line intersects the curve. NOTE: 2% typical rolling resistance is already assumed in chart.
3. Read down from this point to determine maximum speed.

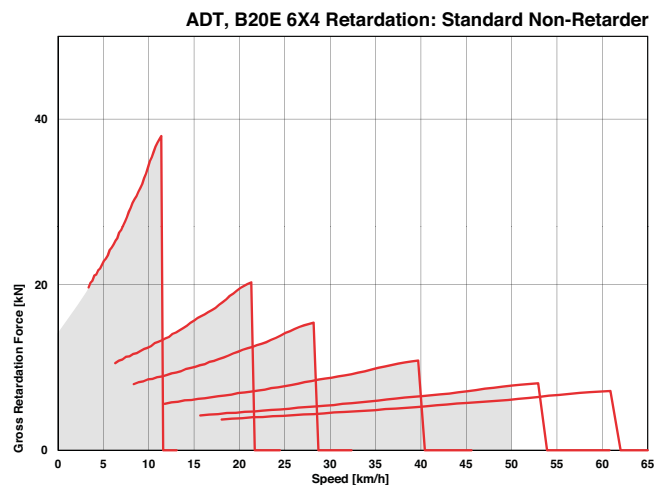
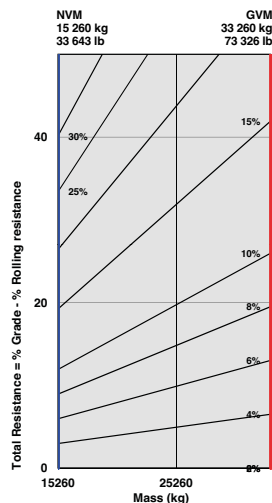

Technical Data - B25E 6x4 Supertruck

<p>ENGINE</p> <p>Manufacturer Mercedes Benz</p> <p>Model OM906LA</p> <p>Configuration Inline 6, turbocharged and intercooled.</p> <p>Gross Power 205 kW (275 hp) @ 2 200 rpm</p> <p>Net Power 198 kW (265 hp) @ 2 200 rpm</p> <p>Gross Torque 1 100 Nm (811 lbf) @ 1 200 -1 600 rpm</p> <p>Displacement 6,37 litres (389 cu.in)</p> <p>Auxiliary Brake Exhaust Valve Brake Engine Valve Brake</p> <p>Fuel Tank Capacity 379 litres (100 US gal)</p> <p>Certification OM906LA meets EU Stage II / EPA Tier 2 emissions regulations</p>	<p>TRANSFER CASE</p> <p>Manufacturer Bell VGR</p> <p>Model 8100</p> <p>Layout Remote mounted</p> <p>Gear Layout Three in-line helical gears</p> <p>Output Differential Interaxle 33/67 proportional differential. Automatic inter-axle differential lock.</p>	<p>WHEELS</p> <p>Type Radial Earthmover</p> <p>Tyre 20.5 R 25</p> <p>FRONT SUSPENSION Semi-independent, leading A-frame supported by hydro-pneumatic suspension struts.</p> <p>REAR SUSPENSION Pivoting walking beams with laminated rubber suspension blocks</p> <p>HYDRAULIC SYSTEM Full load sensing system serving the prioritized steering, body tipping and brake functions. A ground-driven, load sensing emergency steering pump is integrated into the main system.</p> <p>Pump Type Variable displacement load sensing piston</p> <p>Flow 165 l/min (44 gal/min)</p> <p>Pressure 28 Mpa (4 061 psi)</p> <p>Filter 5 microns</p> <p>STEERING SYSTEM Double acting cylinders, with ground-driven emergency steering pump</p> <p>Lock to lock turns 4.1</p> <p>Steering Angle 45°</p>	<p>PNEUMATIC SYSTEM</p> <p>Air drier with heater and integral unloader valve, serving park brake and auxiliary functions.</p> <p>System Pressure 810 kPa (117 psi)</p> <p>ELECTRICAL SYSTEM</p> <p>Voltage 24 V</p> <p>Battery Type Two AGM (Absorption Glass Mat) type</p> <p>Battery Capacity 2 X 75 Ah</p> <p>Alternator Rating 28 V 80 A</p> <p>VEHICLE SPEEDS</p> <table border="1"> <tbody> <tr> <td>1st</td> <td>9 km/h</td> <td>6 mph</td> </tr> <tr> <td>2nd</td> <td>18 km/h</td> <td>11 mph</td> </tr> <tr> <td>3rd</td> <td>27 km/h</td> <td>17 mph</td> </tr> <tr> <td>4th</td> <td>41 km/h</td> <td>25 mph</td> </tr> <tr> <td>5th</td> <td>50 km/h</td> <td>31 mph</td> </tr> <tr> <td>6th</td> <td>50 km/h</td> <td>31 mph</td> </tr> <tr> <td>R</td> <td>8 km/h</td> <td>5 mph</td> </tr> </tbody> </table> <p>CAB ROPS/FOPS certified 74 dBA internal sound level measured according to ISO 6396.</p>	1st	9 km/h	6 mph	2nd	18 km/h	11 mph	3rd	27 km/h	17 mph	4th	41 km/h	25 mph	5th	50 km/h	31 mph	6th	50 km/h	31 mph	R	8 km/h	5 mph
1st	9 km/h	6 mph																						
2nd	18 km/h	11 mph																						
3rd	27 km/h	17 mph																						
4th	41 km/h	25 mph																						
5th	50 km/h	31 mph																						
6th	50 km/h	31 mph																						
R	8 km/h	5 mph																						
<p>TRANSMISSION</p> <p>Manufacturer Allison</p> <p>Model 3500PR ORS</p> <p>Configuration Fully automatic planetary transmission with integral retarder.</p> <p>Layout Engine mounted</p> <p>Gear layout Constant meshing planetary gears, clutch operated</p> <p>Gears 6 Forward, 1 Reverse</p> <p>Clutch Type Hydraulically operated multi-disc</p> <p>Control Type Electronic</p> <p>Torque Control Hydrodynamic with lock-up in all gears</p>	<p>BRAKING SYSTEM</p> <p>Service Brake Dual circuit, full hydraulic actuation dry disc brakes with 8 calipers (4F, 2M, 2R).</p> <p>Maximum brake force: 194 kN (43 613 lbf)</p> <p>Park & Emergency Spring applied, air released driveline mounted disc.</p> <p>Maximum brake force: 170 kN (38 217 lbf)</p> <p>Auxiliary Brake Automatic exhaust valve brake and engine valve brake. Automatic, adjustable, integral, hydrodynamic transmission retarder. Output shaft speed dependant.</p> <p>Total Retardation Power 250 kW (335 hp) Continuous. 539 kW (723 hp) Maximum.</p>	<p>DUMPING SYSTEM</p> <p>Two double-acting, single stage, dump cylinders</p> <p>Raise Time 14,5 s</p> <p>Lowering Time 7,5 s</p> <p>Tipping Angle 70° standard, or any lower angle programmable</p>																						

Load Capacity & Ground Pressure

OPERATING WEIGHTS		GROUND PRESSURE		LOAD CAPACITY		OPTION WEIGHTS	
UNLADEN	kg (lb)	LADEN (No sinkage - Total Contact Area)		BODY	m ³ (yd ³)		kg (lb)
Front	9 640 (21 253)	20.5 R 25	kPa (Psi)	Struck Capacity	12 (15,7)	Extra wheelset	370 (816)
Middle	4 190 (9 237)	Front	305 (44)	SAE 2:1 Capacity	15 (19,5)		
Rear	3 930 (8 664)	Middle	355 (51)	SAE 1:1 Capacity	18 (23,5)		
Total	17 760 (39 154)	Rear	355 (51)				
				Rated Payload	24 000 kg (52 911 lbs)		
LADEN		LADEN (15% sinkage)					
Front	12 370 (27 271)	Front	258 (37)				
Middle	14 760 (32 540)	Middle	301 (44)				
Rear	14 630 (32 254)	Rear	301 (44)				
Total	41 760 (92 065)						

Dimensions

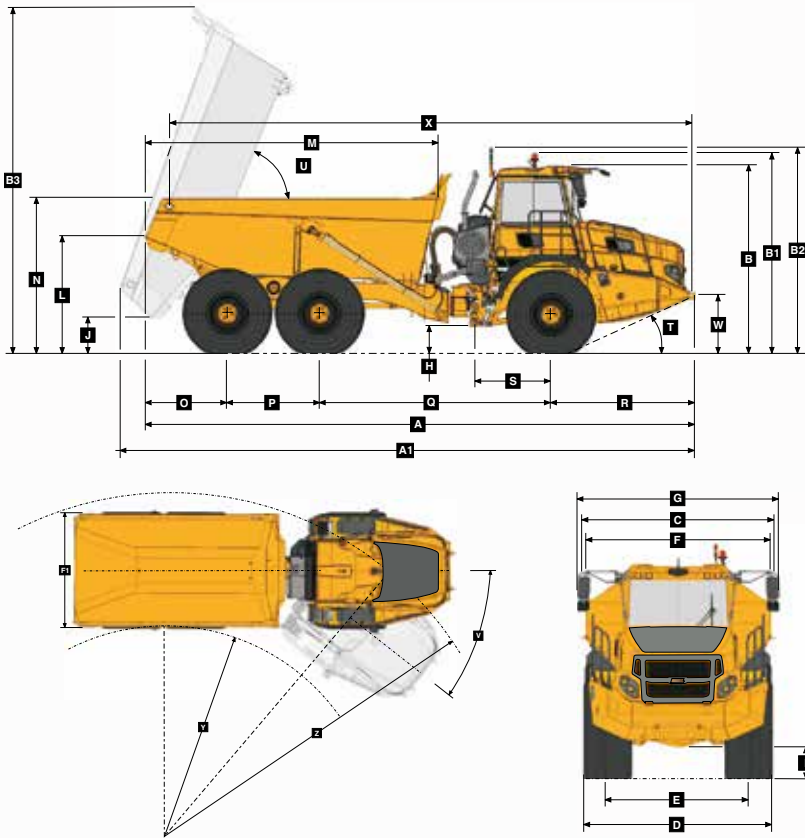

Machine Dimensions

A	Length - Transport Position	9953 mm
A1	Length - Bin Fully Tipped	10311 mm
B	Height - Transport Position	3373 mm
B1	Height - Rotating Beacon	3598 mm
B2	Height - Load Light	3693 mm
B3	Bin Height - Fully Tipped	6198 mm
C	Width over Mudguards	2985 mm
D	Width over Tyres - 20.5R25	2850 mm
E	Tyre Track Width - 20.5R25	2322 mm
F	Width over Bin	2700 mm
F1	Width over Tailgate	2998 mm
G	Width over Mirrors - Operating Position	3260 mm
H	Ground Clearance - Artic	490 mm
I	Ground Clearance - Front Axle	435 mm
J	Ground Clearance - Bin Fully Tipped	615 mm
K	Ground Clearance - Under Run Bar	N/A
L	Bin Lip Height - Transport Position	2116 mm
M	Bin Length	5272 mm
N	Load over Height	2703 mm
O	Rear Axle Centre to Bin Rear	1500 mm
P	Mid Axle Centre to Rear Axle Centre	1670 mm
Q	Mid Axle Centre to Front Axle Centre	4181 mm
R	Front Axle Centre to Machine Front	2602 mm
S	Front Axle Centre to Artic Centre	1362 mm
T	Approach Angle	24 °
U	Maximum Bin Tip Angle	70 °
V	Maximum Articulation Angle	45 °
W	Front Tie Down Height	1024 mm
X	Machine Lifting Centres	9477 mm
Y	Inner Turning Circle Radius - 20.5R25	4155 mm
Z	Outer Turning Circle Radius - 20.5R25	7955 mm

Grade Ability/Rimpull

1. Determine tractive resistance by finding intersection of vehicle mass line and grade line. NOTE: 2% typical rolling resistance is already assumed in chart and grade line.
2. From this intersection, move straight right across charts until line intersects rimpull curve.
3. Read down from this point to determine maximum speed attained at that tractive resistance.

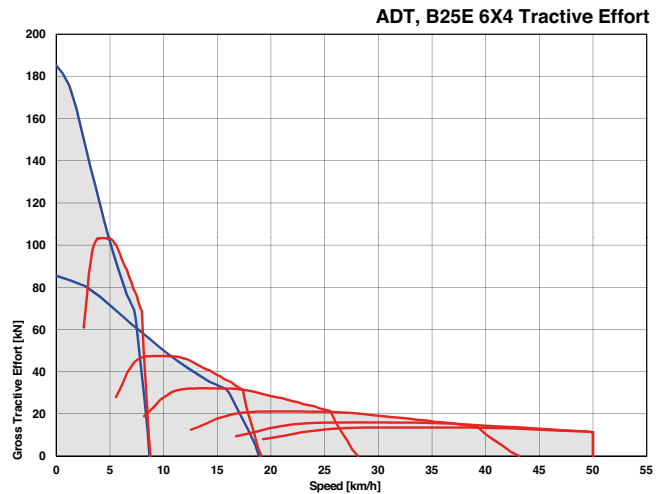
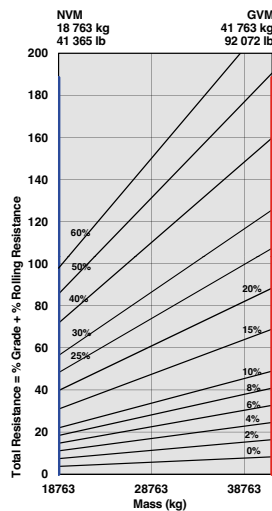

Retardation

1. Determine retardation force required by finding intersection of vehicle mass line.
2. From this intersection, move straight right across charts until line intersects the curve. NOTE: 2% typical rolling resistance is already assumed in chart.
3. Read down from this point to determine maximum speed.

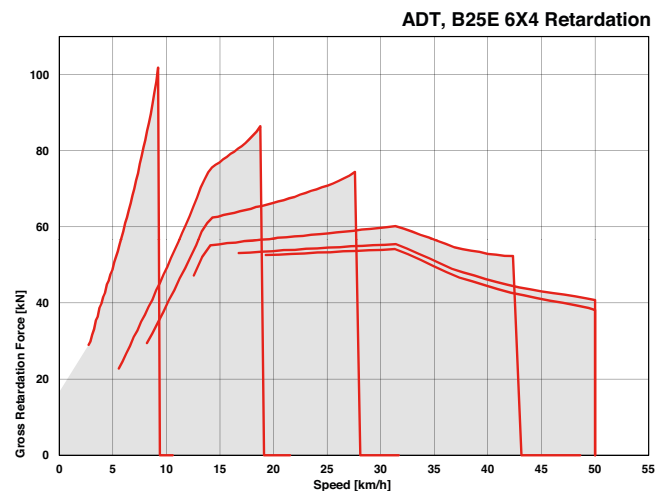
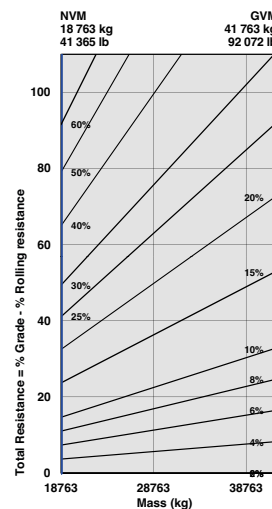

Technical Data - B25E

ENGINE

Manufacturer
Mercedes Benz

Model
OM906LA

Configuration
Inline 6, turbocharged and intercooled.

Gross Power
205 kW (275 hp) @ 2 200 rpm

Net Power
198 kW (265 hp) @ 2 200 rpm

Gross Torque
1 100 Nm (811 lbf) @ 1 200 -1 600 rpm

Displacement
6,37 litres (389 cu.in)

Auxiliary Brake
Exhaust Valve Brake
Engine Valve Brake

Fuel Tank Capacity
379 litres (100 US gal)

Certification
OM906LA meets EU Stage II/EPA Tier 2 emissions regulations.

TRANSMISSION

Manufacturer
Allison

Model
3500PR ORS

Configuration
Fully automatic planetary transmission with integral retarder.

Layout
Engine mounted

Gear layout
Constant meshing planetary gears, clutch operated

Gears
6 Forward, 1 Reverse

Clutch Type
Hydraulically operated multi-disc

Control Type
Electronic

Torque Control
Hydrodynamic with lock-up in all gears.

TRANSFER CASE

Manufacturer
Bell VGR

Model
8100

Layout
Remote mounted

Gear Layout
Three in-line helical gears

Output Differential
Interaxle 33/67 proportional differential. Automatic inter-axle differential lock.

AXLES

Manufacturer
Bell

Model
15T

Differential
High input limited slip differential with spiral bevel gears.

Final Drive
Outboard heavy duty planetary on all axles

BRAKING SYSTEM

Service Brake
Dual circuit, full hydraulic actuation dry disc brakes with 8 calipers (4F, 2M, 2R).

Maximum brake force:
184 kN (41 400 lbf)

Park & Emergency
Spring applied, air released driveline mounted disc.

Maximum brake force:
195 kN (43 900 lbf)

Auxiliary Brake
Automatic exhaust valve brake and engine valve brake. Automatic, adjustable, integral, hydrodynamic transmission retarder. Output shaft speed dependant.

Total Retardation Power
250kW (335 hp) Continuous
539 kW (723 hp) Maximum

WHEELS

Type
Radial Earthmover

Tyre
23.5 R 25

FRONT SUSPENSION

Semi-independent, leading A-frame supported by hydro-pneumatic suspension struts

REAR SUSPENSION

Pivoting walking beams with laminated rubber suspension blocks

HYDRAULIC SYSTEM

Full load sensing system serving the prioritized steering, body tipping and brake functions. A ground-driven, load sensing emergency steering pump is integrated into the main system.

Pump Type
Variable displacement load sensing piston

Flow
165 l/min (44 gal/min)

Pressure
28 Mpa (4 061 psi)

Filter
5 microns

STEERING SYSTEM

Double acting cylinders, with ground-driven emergency steering pump.

Lock to lock turns
4,1

Steering Angle
45°

DUMPING SYSTEM

Two double-acting, single stage, dump cylinders

Raise Time
10 s

Lowering Time
5,5 s

Tipping Angle
70° standard, or any lower angle programmable

PNEUMATIC SYSTEM

Air drier with heater and integral unloader valve, serving park brake and auxiliary functions.

System Pressure
810 kPa (117 psi)

ELECTRICAL SYSTEM

Voltage
24 V

Battery Type
Two AGM (Absorption Glass Mat) type

Battery Capacity
2 X 75 Ah

Alternator Rating
28 V 80 A

VEHICLE SPEEDS

1st	7 km/h	4 mph
2nd	15 km/h	9 mph
3rd	23 km/h	14 mph
4th	35 km/h	22 mph
5th	47 km/h	29 mph
6th	50 km/h	31 mph
R	7 km/h	4 mph

CAB

ROPS/FOPS certified 74 dBA internal sound level measured according to ISO 6396.

Load Capacity & Ground Pressure

OPERATING WEIGHTS		GROUND PRESSURE				LOAD CAPACITY		OPTION WEIGHTS	
UNLADEN	kg (lb)	LADEN (No sinkage)		LADEN (15% sinkage)		BODY	m ³ (yd ³)		kg (lb)
Front	9 740 (21 473)	23.5 R 25	kPa (Psi)	23.5 R 25	kPa (Psi)	Struck Capacity	12 (15,7)	Bin liner	1 050 (2 314)
Middle	4 605 (10 152)	Front	244 (35)	Front	225 (33)	SAE 2:1 Capacity	15 (19,5)	Tailgate	769 (1 695)
Rear	4 565 (10 064)	Middle	336 (49)	Middle	279 (41)	SAE 1:1 Capacity	18 (23,5)	Extra wheelset	565 (1 246)
Total	18 910 (41 689)	Rear	336 (49)	Rear	279 (41)	SAE 2:1 Capacity with tailgate	15,5 (20,3)		
LADEN						Rated Payload	24 000 kg (52 911 lbs)		
Front	12 480 (27 514)								
Middle	15 235 (33 587)								
Rear	15 195 (33 499)								
Total	42 910 (94 600)								

Dimensions

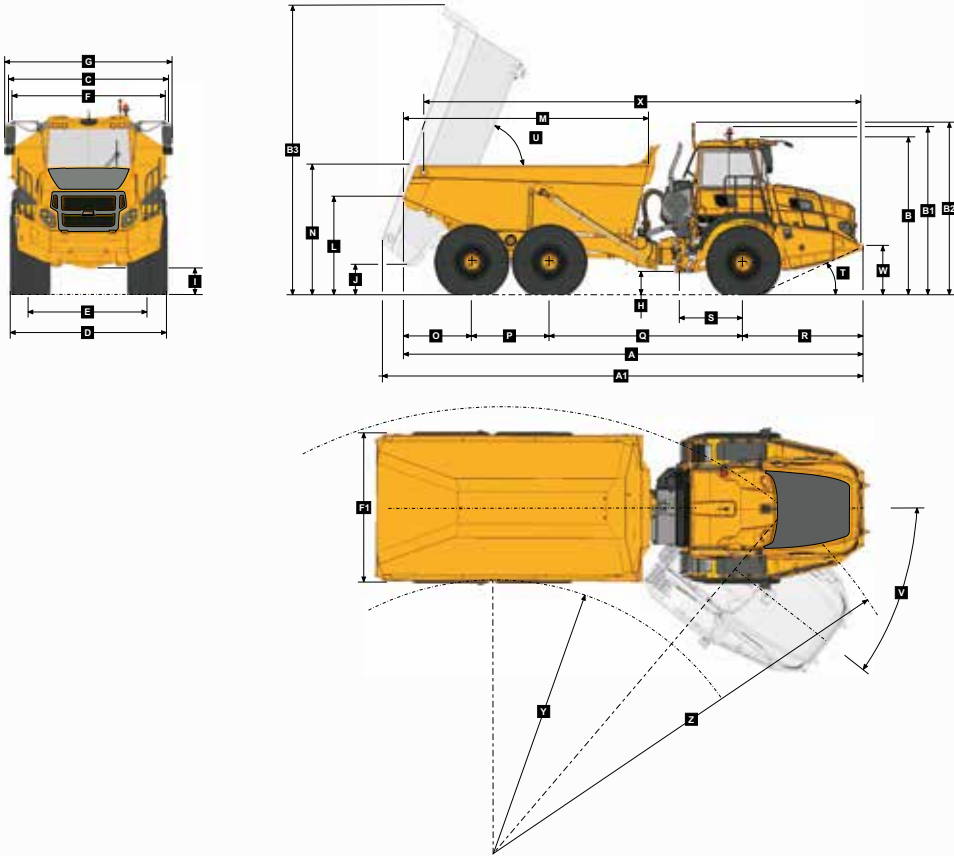

Machine Dimensions

A	Length - Transport Position	9953 mm (32 ft. 7 in.)
A1	Length - Bin Fully Tipped	10311 mm (33 ft. 9 in.)
B	Height - Transport Position	3426 mm (11 ft. 2 in.)
B1	Height - Rotating Beacon	3661 mm (12 ft.)
B2	Height - Load Light	3747 mm (12 ft. 3 in.)
B3	Bin Height - Fully Tipped	6255 mm (20 ft. 6 in.)
C	Width over Mudguards	2985 mm (9 ft. 9 in.)
D	Width over Tyres - 23.5R25	2940 mm (9 ft. 7 in.)
E	Tyre Track Width - 23.5R25	2356 mm (7 ft. 8 in.)
F	Width over Bin	2700 mm (8 ft. 10 in.)
F1	Width over Tailgate	2998 mm (9 ft. 10 in.)
G	Width over Mirrors - Operating Position	3260 mm (10 ft. 8 in.)
H	Ground Clearance - Artic	537 mm (21.14 in.)
I	Ground Clearance - Front Axle	488 mm (19.21 in.)
J	Ground Clearance - Bin Fully Tipped	670 mm (26.38 in.)
K	Ground Clearance - Under Run Bar	N/A
L	Bin Lip Height - Transport Position	2176 mm (7 ft. 1 in.)
M	Bin Length	5272 mm (17 ft. 3 in.)
N	Load over Height	2763 mm (9 ft.)
O	Rear Axle Centre to Bin Rear	1500 mm (4 ft. 11 in.)
P	Mid Axle Centre to Rear Axle Centre	1670 mm (5 ft. 5 in.)
Q	Mid Axle Centre to Front Axle Centre	4181 mm (13 ft. 8 in.)
R	Front Axle Centre to Machine Front	2602 mm (8 ft. 6 in.)
S	Front Axle Centre to Artic Centre	1362 mm (4 ft. 5 in.)
T	Approach Angle	25 °
U	Maximum Bin Tip Angle	70 °
V	Maximum Articulation Angle	45 °
W	Front Tie Down Height	1075 mm (3 ft. 6 in.)
X	Machine Lifting Centres	9477 mm (31 ft. 1 in.)
Y	Inner Turning Circle Radius - 23.5R25	4110 mm (13 ft. 5 in.)
Z	Outer Turning Circle Radius - 23.5R25	8000 mm (26 ft. 2 in.)

Grade Ability/Rimpull

1. Determine tractive resistance by finding intersection of vehicle mass line and grade line. NOTE: 2% typical rolling resistance is already assumed in chart and grade line.
2. From this intersection, move straight right across charts until line intersects rimpull curve.
3. Read down from this point to determine maximum speed attained at that tractive resistance.

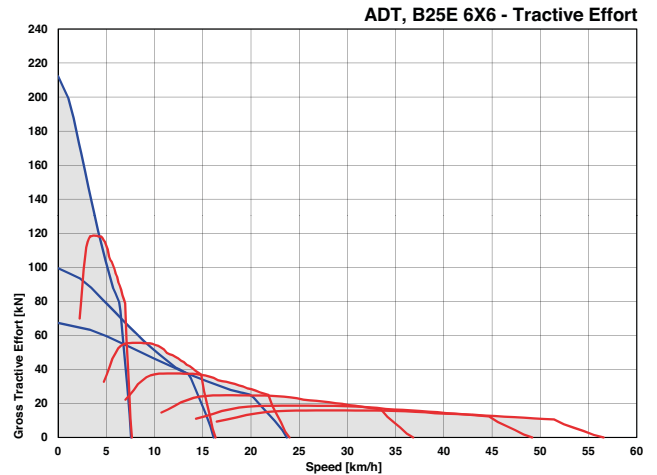
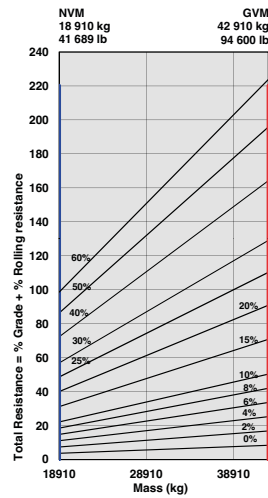

Retardation

1. Determine retardation force required by finding intersection of vehicle mass line.
2. From this intersection, move straight right across charts until line intersects the curve. NOTE: 2% typical rolling resistance is already assumed in chart.
3. Read down from this point to determine maximum speed.

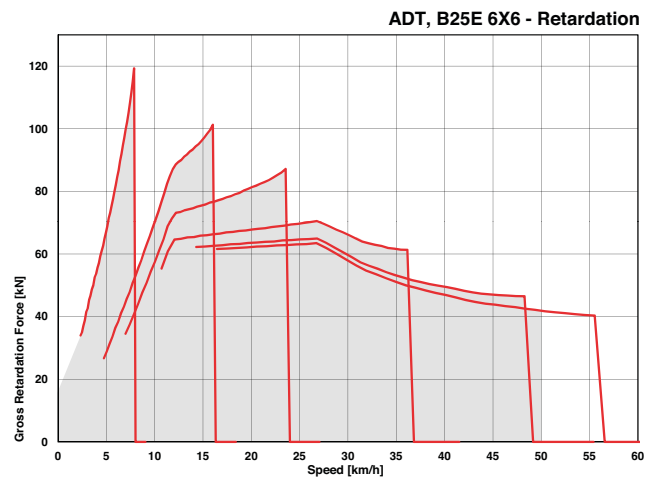
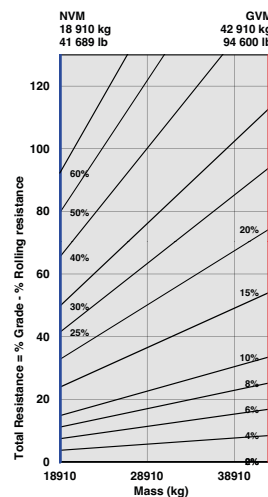

Technical Data - B30E

<p>ENGINE</p> <p>Manufacturer Mercedes Benz</p> <p>Model OM926LA</p> <p>Configuration Inline 6, turbocharged and intercooled.</p> <p>Gross Power 240 kW (322 hp) @ 2 200 rpm</p> <p>Net Power 232 kW (311 hp) @ 2 200 rpm</p> <p>Gross Torque 1 300 Nm (959 lbf) @ 1 200 -1 600 rpm</p> <p>Displacement 7,2 litres (439 cu.in)</p> <p>Auxiliary Brake Exhaust Valve Brake Engine Valve Brake</p> <p>Fuel Tank Capacity 379 litres (100 US gal)</p> <p>Certification OM926LA meets EU Stage II/EPA Tier 2 emissions regulations.</p>	<p>TRANSFER CASE</p> <p>Manufacturer Bell VGR</p> <p>Model 10 000</p> <p>Layout Remote mounted</p> <p>Gear Layout Three in-line helical gears</p> <p>Output Differential Interaxle 33/67 proportional differential. Automatic inter-axle differential lock.</p>	<p>WHEELS</p> <p>Type Radial Earthmover</p> <p>Tyre 23.5 R 25</p>	<p>PNEUMATIC SYSTEM</p> <p>Air drier with heater and integral unloader valve, serving park brake and auxiliary functions.</p> <p>System Pressure 810 kPa (117 psi)</p>																					
<p>TRANSMISSION</p> <p>Manufacturer Allison</p> <p>Model 3500PR ORS</p> <p>Configuration Fully automatic planetary transmission with integral retarder.</p> <p>Layout Engine mounted</p> <p>Gear layout Constant meshing planetary gears, clutch operated</p> <p>Gears 6 Forward, 1 Reverse</p> <p>Clutch Type Hydraulically operated multi-disc</p> <p>Control Type Electronic</p> <p>Torque Control Hydrodynamic with lock-up in all gears.</p>	<p>AXLES</p> <p>Manufacturer Bell</p> <p>Model 18T</p> <p>Differential High input limited slip differential with spiral bevel gears.</p> <p>Final Drive Outboard heavy duty planetary on all axles</p>	<p>FRONT SUSPENSION</p> <p>Semi-independent, leading A-frame supported by hydro-pneumatic suspension struts.</p> <p>REAR SUSPENSION</p> <p>Pivoting walking beams with laminated rubber suspension blocks</p> <p>HYDRAULIC SYSTEM</p> <p>Full load sensing system serving the prioritized steering, body tipping and brake functions. A ground-driven, load sensing emergency steering pump is integrated into the main system.</p> <p>Pump Type Variable displacement load sensing piston.</p> <p>Flow 165 l/min (44 gal/min)</p> <p>Pressure 28 Mpa (4 061 psi)</p> <p>Filter 5 microns</p> <p>STEERING SYSTEM</p> <p>Double acting cylinders, with ground-driven emergency steering pump.</p> <p>Lock to lock turns 4,1</p> <p>Steering Angle 45°</p> <p>DUMPING SYSTEM</p> <p>Two double-acting, single stage, dump cylinders</p> <p>Raise Time 14,5 s</p> <p>Lowering Time 7,5 s</p> <p>Tipping Angle 70° standard, or any lower angle programmable</p>	<p>ELECTRICAL SYSTEM</p> <p>Voltage 24 V</p> <p>Battery Type Two AGM (Absorption Glass Mat) type</p> <p>Battery Capacity 2 X 75 Ah</p> <p>Alternator Rating 28 V 80 A</p> <p>VEHICLE SPEEDS</p> <table border="1"> <tbody> <tr> <td>1st</td> <td>7 km/h</td> <td>4 mph</td> </tr> <tr> <td>2nd</td> <td>15 km/h</td> <td>9 mph</td> </tr> <tr> <td>3rd</td> <td>23 km/h</td> <td>14 mph</td> </tr> <tr> <td>4th</td> <td>35 km/h</td> <td>22 mph</td> </tr> <tr> <td>5th</td> <td>47 km/h</td> <td>29 mph</td> </tr> <tr> <td>6th</td> <td>50 km/h</td> <td>31 mph</td> </tr> <tr> <td>R</td> <td>7 km/h</td> <td>4 mph</td> </tr> </tbody> </table> <p>CAB</p> <p>ROPS/FOPS certified 74 dBA internal sound level measured according to ISO 6396.</p>	1st	7 km/h	4 mph	2nd	15 km/h	9 mph	3rd	23 km/h	14 mph	4th	35 km/h	22 mph	5th	47 km/h	29 mph	6th	50 km/h	31 mph	R	7 km/h	4 mph
1st	7 km/h	4 mph																						
2nd	15 km/h	9 mph																						
3rd	23 km/h	14 mph																						
4th	35 km/h	22 mph																						
5th	47 km/h	29 mph																						
6th	50 km/h	31 mph																						
R	7 km/h	4 mph																						

Load Capacity & Ground Pressure

OPERATING WEIGHTS		GROUND PRESSURE				LOAD CAPACITY		OPTION WEIGHTS	
UNLADEN	kg (lb)	LADEN-No sinkage		LADEN-15% sinkage		BODY	m ³ (yd ³)		kg (lb)
Front	9 750 (21 495)	23.5R25	kPa (Psi)	23.5R25	kPa (Psi)	Struck Capacity	14 (18,3)	Bin liner	1 182 (2 606)
Middle	4 800 (10 582)					Front	280 (41)	Front	240 (35)
Rear	4 760 (10 494)	Middle	378 (55)	Middle	314 (46)	SAE 1:1 Capacity	21 (27,5)	Extra wheelset	565 (1 246)
Total	19 310 (42 571)					Rear	378 (55)		
LADEN									
Front	13 120 (28 925)								
Middle	17 115 (37 732)					Rated Payload	28 000 kg		
Rear	17 075 (37 644)						(61 729 lbs)		
Total	47 310 (104 301)								

Dimensions

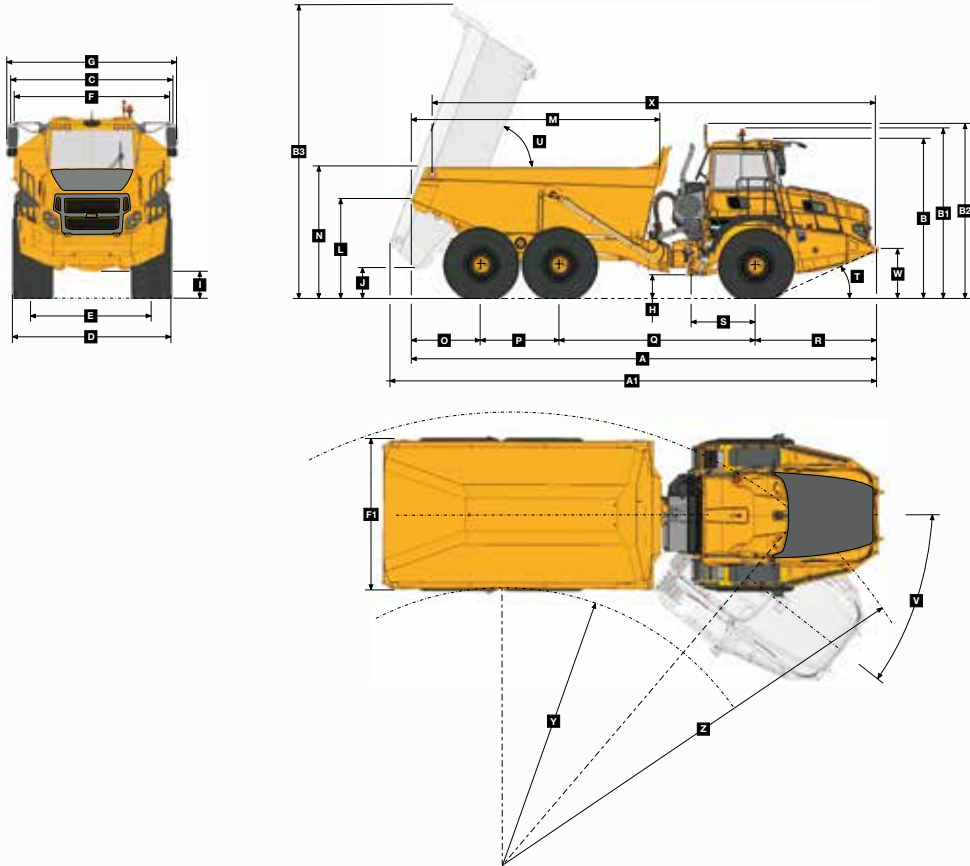

Machine Dimensions	
A	Length - Transport Position 9953 mm (32 ft. 7 in.)
A1	Length - Bin Fully Tipped 10395 mm (34 ft. 1 in.)
B	Height - Transport Position 3426 mm (11 ft. 2 in.)
B1	Height - Rotating Beacon 3661 mm (12 ft.)
B2	Height - Load Light 3747 mm (12 ft. 3 in.)
B3	Bin Height - Fully Tipped 6307 mm (20 ft. 8 in.)
C	Width over Mudguards 2985 mm (9 ft. 9 in.)
D	Width over Tyres - 23.5R25 2940 mm (9 ft. 7 in.)
D1	Width over Tyres - 750/65 R25 2998 mm (9 ft. 10 in.)
E	Tyre Track Width - 23.5R25 2356 mm (7 ft. 8 in.)
E1	Tyre Track Width - 750/65 R25 2260 mm (7 ft. 4 in.)
F	Width over Bin 2968 mm (9 ft. 8 in.)
F1	Width over Tailgate 3268 mm (10 ft. 8 in.)
G	Width over Mirrors - Operating Position 3260 mm (10 ft. 8 in.)
H	Ground Clearance - Artic 537 mm (21.14 in.)
I	Ground Clearance - Front Axle 488 mm (19.21 in.)
J	Ground Clearance - Bin Fully Tipped 670 mm (26.38 in.)
K	Ground Clearance - Under Run Bar N/A
L	Bin Lip Height - Transport Position 2176 mm (7 ft. 1 in.)
M	Bin Length 5294 mm (17 ft. 4 in.)
N	Load over Height 2864 mm (9 ft. 4 in.)
O	Rear Axle Centre to Bin Rear 1500 mm (4 ft. 11 in.)
P	Mid Axle Centre to Rear Axle Centre 1670 mm (5 ft. 5 in.)
Q	Mid Axle Centre to Front Axle Centre 4181 mm (13 ft. 8 in.)
R	Front Axle Centre to Machine Front 2602 mm (8 ft. 6 in.)
S	Front Axle Centre to Artic Centre 1362 mm (4 ft. 5 in.)
T	Approach Angle 25 °
U	Maximum Bin Tip Angle 70 °
V	Maximum Articulation Angle 45 °
W	Front Tie Down Height 1075 mm (3 ft. 6 in.)
X	Machine Lifting Centres 9443 mm (30 ft. 11 in.)
Y	Inner Turning Circle Radius - 23.5R25 4110 mm (13 ft. 5 in.)
Y1	Inner Turning Circle Radius - 750/65 R25 4081 mm (13 ft. 4 in.)
Z	Outer Turning Circle Radius - 23.5R25 8000 mm (26 ft. 2 in.)
Z1	Outer Turning Circle Radius - 750/65 R25 8029 mm (26 ft. 4 in.)

Grade Ability/Rimpull

1. Determine tractive resistance by finding intersection of vehicle mass line and grade line. NOTE: 2% typical rolling resistance is already assumed in chart and grade line.
2. From this intersection, move straight right across charts until line intersects rimpull curve.
3. Read down from this point to determine maximum speed attained at that tractive resistance.

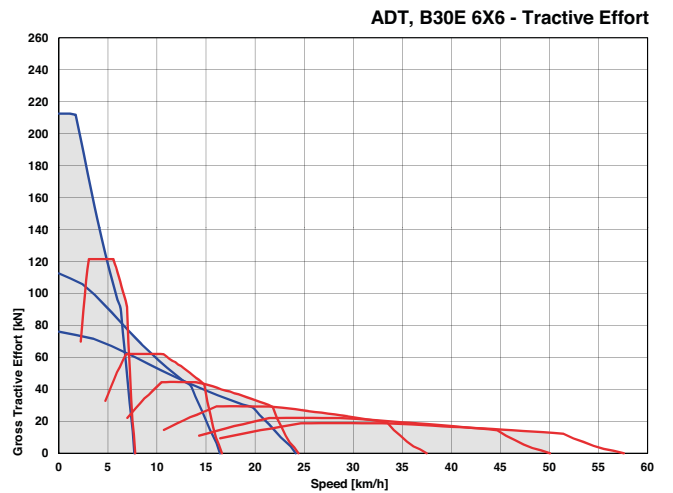
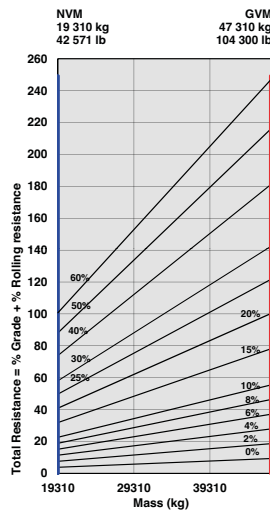

ADT, B30E 6X6 - Tractive Effort

Retardation

1. Determine retardation force required by finding intersection of vehicle mass line.
2. From this intersection, move straight right across charts until line intersects the curve. NOTE: 2% typical rolling resistance is already assumed in chart.
3. Read down from this point to determine maximum speed.

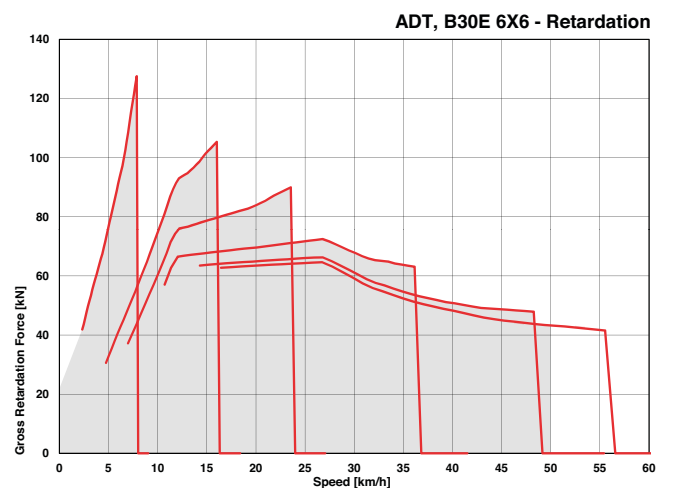
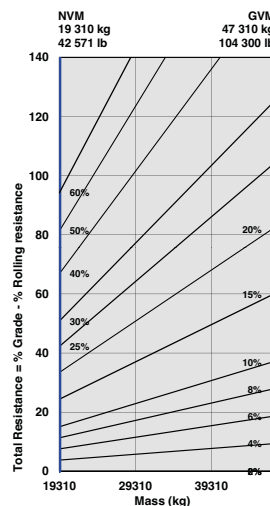

ADT, B30E 6X6 - Retardation

Features and Options

	B18E	B20E	B25E (6x4)	B25E	B30E		B18E	B20E	B25E (6x4)	B25E	B30E	
						● STANDARD ▲ OPTION						● STANDARD ▲ OPTION
ENGINE												
●	●	●	●	●	●	Engine valve brake and exhaust brake	●	●	●	●	●	
●	●	●	●	●	●	Dual element air cleaner with dust ejector valve						
●	●	●	●	●	●	Precleaner with automatic dust scavenging						
●	●	●	●	●	●	Water separator						
●	●	●	●	●	●	Serpentine drive belt with automatic tensioner						
COOLING												
●	●	●	●	●	●	Crankshaft mounted electronically controlled viscous fan drive						
●	●	●	●	●	●	Fan guard						
PNEUMATIC SYSTEM												
●	●	●	●	●	●	Engine-mounted compressor	▲	▲	▲	▲	▲	
●	●	●	●	●	●	Air drier with heater						
●	●	●	●	●	●	Integral unloader valve						
ELECTRICAL SYSTEM												
●	●	●	●	●	●	Battery disconnect						
●	●	●	●	●	●	Drive lights	▲	▲	▲	▲	▲	
▲	▲	▲	▲	▲	▲	Deluxe work lights	▲	▲	▲	▲	▲	
●	●	●	●	●	●	Air Horn	▲	▲	▲	▲	▲	
●	●	●	●	●	●	Reverse alarm	▲	▲	▲	▲	▲	
●	●	●	●	●	●	Rotating beacon				▲		
●	●	●	●	●	●	Pitch Roll sensor						
▲	▲	▲	▲	▲	▲	Artic reverse light						
STEERING SYSTEM												
●	●	●	●	●	●	Ground-driven secondary steering pump	▲	▲	▲	▲	▲	
▲	▲	▲	▲	▲	▲	Bi-directional ground driven secondary steering pump	▲	▲	▲	▲	▲	
CAB												
Standard Cab												
●	●	●	●	●	●	ROPS/FOPS certification	●	●	●	●	●	
●	●	●	●	●	●	Tilt cab	●	●	●			
●	●	●	●	●	●	Gas strut-supported door				●	●	
●	●	●	●	●	●	I-Tip programmable dump-body tip settings	●	●	●	●	●	
●	●	●	●	●	●	HVAC Climate control system	▲	▲	▲	▲	▲	
●	●	●	●	●	●	Rear window guard	●	●	●	●	●	
●	●	●	●	●	●	Wiper/washer with intermittent control	▲	▲	▲	▲	▲	
●	●	●	●	●	●	Tilt and telescoping steering wheel				▲	▲	▲
●	●	●	●	●	●	Centre-mount air-suspension seat				▲	▲	▲
●	●	●	●	●	●	Retractable 3-point seat belt	▲	▲	▲	▲	▲	
●	●	●	●	●	●	Foldaway trainer seat with retractable seat belt				▲	▲	▲
●	●	●	●	●	●	12-volt power outlet	●	●	●	●	●	
●	●	●	●	●	●	Cup holder				▲	▲	
●	●	●	●	●	●	Cooled/heated lunch box	▲	▲	▲	▲	▲	
●	●	●	●	●	●	Backlit sealed switch module functions with:	▲	▲	▲	▲	▲	
						Wiper control / Lights / Heated mirrors /	●	●	●	●	●	
						Retarding aggressiveness / Transfer case						
						differential lock / Transmission gear hold /	▲	▲	▲	▲	▲	
						Dump-body tip limit / Automatic dump-body						
						tip settings / Airconditioner/ Heater controls /	▲	▲	▲	▲	▲	
						Preselected Speed Control						
Standard Cab (continued)												
						Deluxe 10" colour LCD:	●	●	●	●	●	
						Speedometer / Fuel gauge /						
						Transmission oil temperature gauge /						
						Engine coolant temperature gauge /						
						LED function/warning indicators and audible						
						alarm / Transmission gear selection /						
						Tachometer / Battery voltage / Hour meter /						
						Odometer / Fuel consumption / Tip counter /						
						Trip timer / Trip distance / Metric/English units /						
						Service codes/diagnostics						
Deluxe Cab												
						AM/FM radio/CD player						
						Forward work lights						
						Electric adjustable and heated mirrors						
						Extra wide wiper system						
Cab Extras												
						LED work lights	▲	▲	▲	▲	▲	
						Rotating beacon: seat belt installation	▲	▲	▲	▲	▲	
						Remote engine and machine isolation	▲	▲	▲	▲	▲	
						Remote battery jump start	▲	▲	▲	▲	▲	
						High visibility mirrors						
DUMP BODY												
						Partial up dump-body mechanical lock	●	●	●	●	●	
						Fully up dump-body mechanical lock	▲	▲	▲	▲	▲	
						Body liner	▲	▲	▲	▲	▲	
						Tailgate						
						Body heater	▲	▲	▲	▲	▲	
						Less dump body and cylinders	▲	▲	▲	▲	▲	
OTHER												
						Automatic Traction Control (ATC)	●	●	●	●	●	
						20.5R25 Radial earthmover tyres	●	●	●			
						23.5R25 Radial earthmover tyres				●	●	
						Remote grease banks	●	●	●	●	●	
						Automatic greasing	▲	▲	▲	▲	▲	
						Onboard weighing	●	●	●	●	●	
						Load lights: stack	▲	▲	▲	▲	▲	
						Comfort ride suspension (Front)				▲	▲	▲
						Comfort ride suspension (Rear)				▲	▲	▲
						Reverse camera	▲	▲	▲	▲	▲	
						Hand rails						
						Cab peak	●	●	●	●	●	
						Deluxe bonnet						
						High pressure hydraulic filter	▲	▲	▲	▲	▲	
						Fuel heater	▲	▲	▲	▲	▲	
						Belly cover	●	●	●	●	●	
						Cross member cover						
						Remote transmission filters	▲	▲	▲	▲	▲	
						Window smash button						

Notes



All dimensions are shown in millimetres, unless otherwise stated between brackets. Under our policy of continuous improvement, we reserve the right to change technical data and design without prior notice. Photographs featured in this brochure may include optional equipment.

BELL INTERNATIONAL: Tel: +27 (0)35-907 9431

E-mail: marketing@bellequipment.com

Web: www.bellequipment.com



Tel: +61 (0)8-9356 1033



Tel: +49 (0)6631 / 91-13-0



Tel: +27 (0)11-928-9700



Tel: +44 (0)1283-712862



Tel: +33 (0)5-55-89-23-56



Tel: +7 495-287-80-02



Tel: +1-855-494-2355

**Strong Reliable Machines
Strong Reliable Support**

BELL