

Unit Rig™ Mining Trucks

Product Line





Moving You Forward

The superior safety, reliability and productivity of Unit Rig™ trucks are the product of top-quality engineering standards. Our relentless pursuit of engineering excellence is motivated by our passion for mining, which we share with our customers.

Unit Rigs

Unit Rig trucks are engineered with AC drive systems and are tough, reliable performers specifically designed for high-volume surface mines. The unique advantages engineered throughout Unit Rig mining trucks deliver high productivity, impressive uptime, ease of service and a safe, productive operator environment for a low cost of ownership. Fast cycle times are achieved with rapid uphill, downhill and flat-terrain speeds. Unit Rig mining trucks are built for long life and high availability with a unique beam axle suspension that carries road stress and separates it from the frame, effectively reducing frame shock loads. Because they need few fluids and consumables, our trucks require less service time and reduce operating, service and waste management costs. Operator comfort is enhanced with a smooth ride, made possible by the unique front suspension,

a wide chassis and the AC drive system, which produces smooth acceleration and deceleration without gear shifts.

Unit Rig trucks offer a compelling combination of systems for heavy-duty performance and a low total cost of ownership.

Machine Service & Support

Factory-trained service engineers are available throughout the world to provide our customers with the support necessary to meet their production requirements. Our service engineers have the knowledge and experience to bring a successful result to the most demanding projects. In addition, they are backed by our team of engineers, who have design-based knowledge not available from other sources.



Open/Flat

Unit Rig trucks have quick flat-terrain acceleration because of high horsepower, a high power-to-weight ratio and high drivetrain efficiency. The AC drive system also allows the operator to safely react to changing conditions by transitioning the truck from full propel to maximum dynamic retarding in less than two seconds.

Downhill

The AC drive system produces 2 011–4 476kW (2,700–6,000 hp) of dynamic retarding across all operating speeds, which allows rapid, safe operation.

Uphill

Quick uphill speeds are achieved with the AC drive system, which effectively converts horsepower to high rim pull force.

The Unit Rig Speed Advantage

Unit Rig trucks incorporate unique advantages to deliver outstanding productivity, helping you more efficiently reach your goals. As detailed below, Unit Rig mining trucks achieve fast cycle times and move more material in less time. Also enhancing productivity is the electric drivetrain, which has fewer mechanical losses, increasing fuel economy and availability by lowering time spent refueling.

AC Drive System

Unit Rig mining trucks feature superior AC drive systems and IGBT technology that utilizes a wide range of horsepower while significantly reducing friction brake wear. The AC drive system facilitates transitioning from full propel to 90% retard in less than two seconds. Likewise, the improved dynamic retarding controls truck speed down to less than 1.60 km (1.0 mile) per hour without braking. The AC drive system ensures excellent serviceability even in the most severe haul conditions, reducing associated operating costs and improving reliability.

Strong Frame

Unit Rig frames have a double-box structure featuring straight rails with integral tubular cross-members for increased structural rigidity. Double-shear mountings for the suspension, hydraulic and hoist cylinders are standard and add strength.

Beam Axle Suspension

A beam axle carries road stress, separating it from the frame by long-travel hydraulic cylinders that are pinned at the top and bottom. This allows the suspension to reduce frame-shock loads, helping improve handling, maneuverability and tire life.

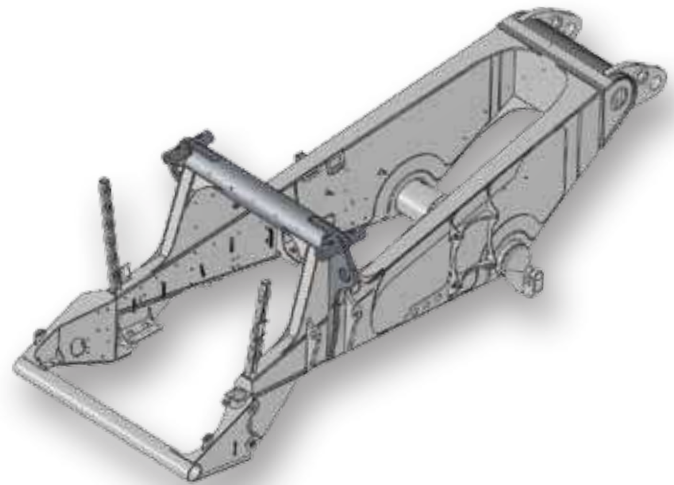

Robust, Long-Tailed Dump Body

The conventional Unit Rig dump body is designed with a unique, patented floating bolster. Longitudinal reinforcement is relieved at each cross bolster to reduce stress and extend structural life expectancy.

The floor is manufactured with Hardox 400 body plates for improved wear in the body's center. Also adding strength is a perimeter beam that provides support while runners transfer weight to the frame.

Unit Rig mining truck bodies are extended rearward beyond the sides to reduce spillage, unlike competitor models that cut the bed floor off at a normal angle to the sides.



Beam axle suspension

Electric Drivetrain

Unit Rig trucks feature an electric drivetrain with approximately one-third the number of gears and one-seventh the number of bearings traditional mechanical drivetrains use. With fewer wear items, the electric drivetrain requires less regular maintenance, reducing service cost.

Traction Control

A control system automatically adjusts propel and retard torque to each individual wheel motor to correct any wheel spin.

Simple Hydraulic System

The hydraulic system's two-pump design has large-capacity accumulators and organized hose routing for a simple, reliable design that's easy to service.



Long-tailed, extended bodies

Few Consumables and Fluids

Competitor trucks can require approximately twice the volume of fluids as Unit Rig mining trucks, which don't use steering and transmission fluids. Lower fluid requirements mean Unit Rig trucks use fewer consumable oil filters, reducing operating, service and waste management costs, as well as decreasing service time, which expands availability.

Superior Maintenance Profile

Component life and serviceability intervals for Unit Rig mining trucks have been aligned to allow for the fewest possible planned maintenance events. The result is less scheduled downtime and greater availability.

Low-Wear Braking

Unit Rig mining trucks use electrical retarding as their primary braking method, which lowers service requirements and enhances uptime. Air-cooled mechanical brakes provide service and emergency braking. Because electrical braking is produced by the wheel motors, it does not cause wear from friction, and there are no brake fluids to replace or discard.

Convenient Component Access

To ease maintenance, Unit Rig mining trucks are designed with clear access to the engine and alternator, a convenient technician walkway and a hydraulic system control panel that's safely located in a cabinet on top of the superstructure.

Safe, Comfortable Cab

Unit Rig mining trucks offer best-in-class visibility, giving operators a 191-degree field of view. This is achieved through the use of a curved windshield that eliminates A-pillars, providing the operator with expanded views that aid in safety and efficiency.

Unit Rig trucks feature cabs that have rollover and falling object protective structures, meet SAE J-1040 requirements and are designed to deform the beams that support the cab rather than compromise the operator compartment.

Two full-size seats, backlit cab instrumentation and a pressurized and fresh air filtration system keep drivers comfortable and productive. A sound-abatement system reduces the noise level



Simple hydraulic system



Low-wear braking



Convenient component access for easier maintenance



Safe, comfortable cab

MT6300



- 363 tonne (400 ton) payload capacity – largest mining truck in the industry
- Operating weight: 603 278 kg (1,330,000 lb)
- Rated power: 2 796 kW (3,750 hp)
- 4-pass load capability when paired with Cat® 7495 hard-rock/high-flotation electric rope shovel
- 4-pass load capability when paired with Cat 6090 hydraulic shovel
- 6-pass load capability when paired with Cat 6060 hydraulic shovel
- Triple-reduction wheel motor offers gear ratios from 32:1 to 42:1
- Patented hybrid dump body design includes special runners that transfer weight to the frame and joint isolation that reinforces welding areas
- Dump body heating available
- Ground clearance of 910 mm (36 in) when fully loaded

MT5500



- 326 tonne (360 ton) payload capacity
- Operating weight: 543 404 kg (1,198,000 lb)
- Rated power: 2 014 kW (2,700 hp)
- 3-pass load capability when paired with Cat 7495 hard-rock/high-flotation electric rope shovel
- 4-pass load capability when paired with Cat 6090 hydraulic shovel
- 5-pass load capability when paired with Cat 6060 hydraulic shovel
- Patented horizontal bolster deep-V dump body design with flat floor and 45° dumping angle
- Dump body heating available

MT4400



- 221 tonne (244 ton) payload capacity
- Operating weight: 392 357 kg (865,000 lb)
- Rated power: 1 864 kW (2,500 hp)
- 3-pass load capability when paired with Cat 7495 heavy-duty electric rope shovel or 6090 hydraulic shovel
- 4-pass load capability when paired with Cat 6060 hydraulic shovel
- 5-pass load capability when paired with Cat 6050 hydraulic shovel
- Central hydraulic service box located on superstructure is easily accessible
- Patented horizontal bolster deep-V dump body design with flat floor and 45° dumping angle
- Dump body heating available

- 186 tonne (205 ton) payload capacity
- Operating weight: 335 600 kg (740,000 lb)
- Rated power: 1 492 - 1 864 kW (2,000 - 2,500 hp)
- 3-pass load capability when paired with Cat 6060 hydraulic shovel
- 4-pass load capability when paired with Cat 6050 hydraulic shovel
- Patented horizontal bolster deep-V dump body design with flat floor and 45° dumping angle
- Dump body heating available



MT3700

- 136 tonne (150 ton) payload capacity
- Operating weight: 251 701 kg (555,000 lb)
- Rated power: 1 193 - 1 398 kW (1,600 - 1,875 hp)
- 3-pass load capability when paired with Cat 6050 hydraulic shovel
- 4-pass load capability when paired with Cat 6040 hydraulic shovel
- Patented horizontal bolster deep-V dump body design with flat floor and 45° dumping angle
- Dump body heating available



MT3300

Model	Payload	Rated Power	Loaded Weight	Max Speed								
					6018	6030	6040	6050	6060	6090	7495 HD	7495 HR/HF
					10.0 m ³ 13.1 yd ³	16.5 m ³ 21.6 yd ³	22.0 m ³ 28.8 yd ³	26.0 m ³ 34.0 yd ³	34.0 m ³ 44.5 yd ³	50.0 m ³ 65.4 yd ³	51.2 m ³ 67.0 yd ³	62.7 m ³ 82.0 yd ³
MT6300	363 tonnes (400 tons)	2 796 kW (3,750 hp)	603 278 kg (1,330,000 lb)	64 km/h (40 mph)				7-8 passes	6 passes	4 passes	4-5 passes	3-4 passe
MT5500	326 tonnes (360 tons)	2 014 kW (2,700 hp)	543 404 kg (1,198,000 lb)	64 km/h (40 mph)				6-7 passes	5 passes	3-4 passes	4 passes	3 passes
MT4400	221 tonnes (244 tons)	1 864 kW (2,500 hp)	392 357 kg (865,000 lb)	64 km/h (40 mph)			5-6 passes	4-5 passes	3-4 passes		3 passes	2-3 passes
MT3700	186 tonnes (205 tons)	1 492 - 1 864 kW (2,000-2,500 hp)	335 600 kg (740,000 lb)	64 km/h (40 mph)		6 passes	5 passes	4 passes	3 passes			
MT3300	136 tonnes (150 tons)	1 193 - 1 398 kW (1,600-1,875 hp)	251 701 kg (555,000 lb)	64 km/h (40 mph)	7-8 passes	4-5 passes	3-4 passes	3 passes				

Unit Rig Mining Trucks – Product Line

For more complete information on Cat products, dealer services, and industry solutions, visit us on the web at mining.cat.com and www.cat.com

© 2011 Caterpillar Inc.
All rights reserved

Materials and specifications are subject to change without notice. Featured machines in photos may include additional equipment. See your Cat dealer for available options.

CAT, CATERPILLAR, their respective logos, “Caterpillar Yellow” and the “Power Edge” trade dress, as well as corporate and product identity used herein, are trademarks of Caterpillar and may not be used without permission.

AEXQ0601-01

