

McNeilus

S-SERIES FRONT DISCHARGE MIXER DRIVEN BY OSHKOSH



High performance meets low maintenance with the McNeilus S-Series Front Discharge Mixer.

- Parts and service network strategically located to keep your trucks on the job and working hard for you
- In-house testing capabilities that are unmatched in the industry, giving you a product that is proven tough
- Streamlined warranty system gets you back to work faster
- Flex financing programs designed to make it easy for you to obtain the industry's best-built front discharge trucks
- World-class maintenance training available to optimize your vehicles' life cycle cost
- Oshkosh chassis

STANDARD FEATURES

MIXER DRUM

CAPACITY

11 cu yd* (TMMB certified)

SHELL CONSTRUCTION

0.21 in. AR200 abrasion-resistant steel

0.19 in. steel discharge cone

10-gauge steel discharge cone extension

0.25 in. spun steel head

0.21 in. fins with weep holes

INSPECTION HATCH

2 bolt-on hatches

DISCHARGE OPENING

45 in

DRIP RING

Single drip ring

ROLLERS

8 in. diameter alloy steel

CHARGE HOPPER

CHARGE HOPPER TYPE

Two-stage, high-strength steel

CHARGE HOPPER CONTROLS

Stationary

COLLECTOR WIDTH

40 in

THROAT WIDTH

26 in

DISCHARGE HOPPER

DISCHARGE HOPPER MATERIAL

Steel

MIXER DRIVE

PUMP

Eaton 54 Series with integral charge pump and filter

MOTOR

Eaton 46 Series

TRANSMISSION

ZF P7300

CHUTE DISCHARGE

MANUAL CHUTES

Main chute with 16.19 in. wide (at hook) flip-over section plus 4x 48 in. long extensions

POWER CHUTES

3-stage hydraulic fold with 2x 16.19 in. wide (at hook)

3-stage hydraulic fold with 2x 16.19 in. wide (at hook)

4-stage fold (2nd and 3rd stage hydraulic fold, 4th stage manual fold) with 16.19 in. wide (at hook)

EXTENSION CHUTES

Steel 16.19 in. wide (at hook), 48 in. long

TOTAL CHUTE LENGTH

Up to 21 ft 9 in

EXTENSION CHUTE ATTACHMENT

Rubber bungee

CHUTE LIFT CYLINDER

Double extending

BRAKES

EMERGENCY

Spring operated on rear tandem

SERVICE FRONT STEER/

REAR TANDEM AXLES

Dual system, air-operated modulated, 16.5 in. x 7 in.

S-cam with automatic slack adjusters

OSHKOSH LSTA

15 in. x 4 in. S-cam with automatic slack adjusters

AUXILIARY AXLES

16.5 in. x 7 in. S-cam with automatic slack adjusters (fixed 20K)

16.5 in. x 5 in. S-cam with automatic slack adjusters (steerable 20K)

15 in. x 4 in. S-cam with automatic slack adjusters (steerable/fixed 13.5K)

AIR DRYER

SKF Brakemaster Turbo2000

COMPRESSOR

Wabco (18.7 cfm) w/ Cummins engines

Bendix (15.8 cfm) w/ Detroit

MIXER CONTROLS

MECHANICAL CONTROLS

Internal mixer controls

Dash-mounted mechanical lever to control drum speed and charge/discharge

Cable chute control joystick with drum start/stop button

External mixer controls

Lever in bumper to control chutes

EATON EP (ELECTRONIC PROPORTIONAL) CONTROLS (opt)

Internal mixer controls

Cable chute control joystick with buttons to control drum speed and charge/discharge

External mixer controls

Lever in bumper to control chutes

EATON RE (REMOTE ELECTRONIC) CONTROLS (opt)

Internal mixer controls

Cable chute control joystick with buttons to control drum speed and charge/discharge

External mixer controls

Lever in bumper to control chutes

INSPECTION PLATFORM

ACCESS LADDER

Straight 16 in. wide with grip-type rungs, located at front left (std)

PLATFORM

Grated platform provides access to both sides of drum opening and includes guard rail

WATER SYSTEM

55 PSI STEEL TANKS

150 gallon with sight gauge, LH fill

WASH-DOWN HOSES

25 ft upper, 30 ft lower

S-SERIES FRONT DISCHARGE MIXER
DRIVEN BY OSHKOSH

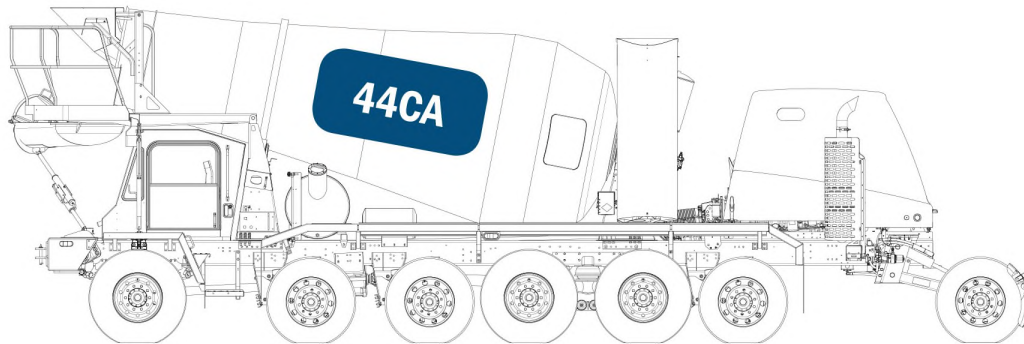
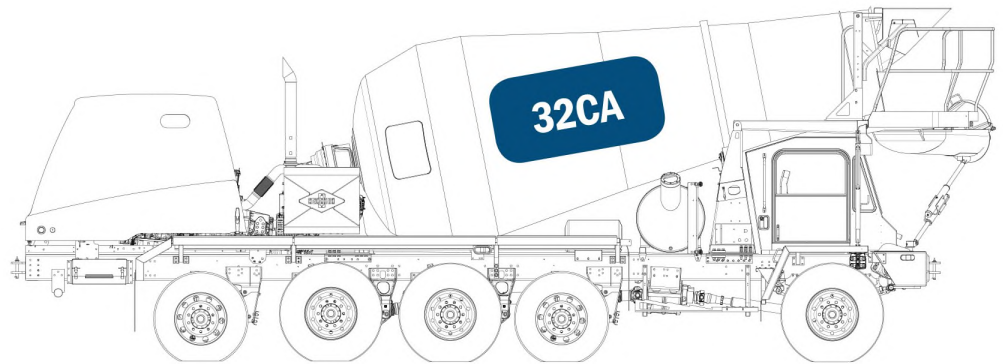
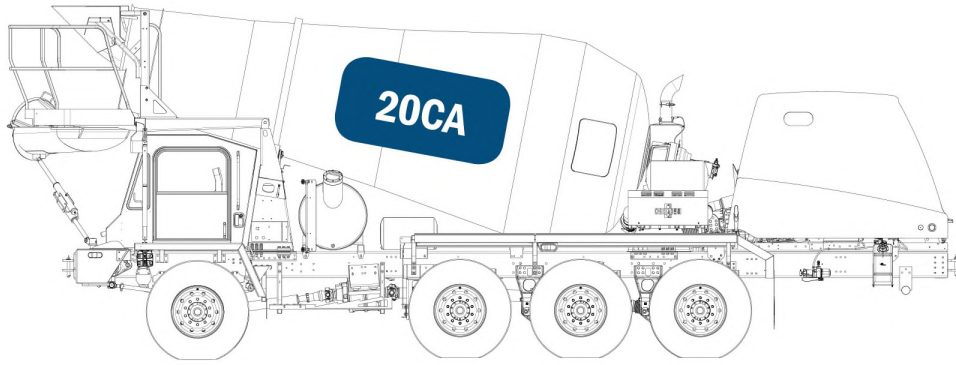

STANDARD FEATURES

ENGINES

CUMMINS ISX12 (11.9L) (diesel)

Ratings

350hp @ 1,800 RPM, 1,450 ft-lb

385hp @ 1,800 RPM, 1,450 ft-lb

425hp @ 1,800 RPM, 1,550 ft-lb

Governed RPM

2,100

Aftertreatment

Horizontal DPF mounted to left of rear drive pedestal,

vertical SCR mounted on right of rear drive pedestal

Diesel exhaust fluid tank

5 gallon, frame mounted

Block heater

120V Kim-Glo

CUMMINS ISX12 G (11.9L) (compressed natural gas)

Ratings

350hp @ 1,700 RPM, 1,450 ft-lb

400hp @ 1,800 RPM, 1,450 ft-lb

Governed RPM

2,100

Exhaust

3-way catalyst, frame mounted to left of engine

Block heater

120V Kim-Glo

DETROIT DIESEL DD13 (12.8L) (diesel)

Ratings

380hp @ 1,800 RPM, 1,450 ft-lb

435hp @ 1,800 RPM, 1,550 ft-lb

Governed RPM

2,080

Aftertreatment

1-box mounted to left of rear drive pedestal

Diesel exhaust fluid tank

5 gallon, frame mounted

Block heater

120V Kim-Glo

TRANSMISSION

ALLISON RDS WITH GEN 5 ELECTRONICS

Allison RDS4000

5-speed automatic

SHIFTER CONTROLS

Push-button keypad

TRANSFER CASE

ALUMINUM

Oshkosh aluminum

High: 1.00:1; low: 2.48:1

Front axle declutch (air-actuated)

STEEL

Oshkosh 21000 Series

High: 1.00:1; low: 2.38:1

Front axle declutch (air-actuated)

CHASSIS OPTIONS

FRONT BUMPER/DECK PLATE

Steel

Headlight Bezel

Black

ENGINE COVER

One-piece fiberglass engine enclosure with steel bolt-on grill

Grill

Black steel

Air-over-hydraulic lift system

FENDER

Front

Steel

Rear/Auxiliary

Steel

LSTA/HLTA

Plastic 80°

FUEL SYSTEM

Diesel

Aluminum

Compressed natural gas

75 Diesel Gallon Equivalent

Two tanks (Type 4) mounted vertically to drive pedestal

NGV1 fill port left side by drive pedestal

McNeilus MA20 fuel box

CAB ACCESS

Cable step

CAB

CONSTRUCTION

Oshkosh one-man, center placement, aluminum construction, 45 in. cab width

ACCESSORIES

2.5 lb dry chemical fire extinguisher, highway safety triangles

Highly visible orange three-point seatbelt

Heated mirrors with separate 8 in. convex

Tilt steering column

AM/FM radio with CD

National high back seat with armrests

Air horn

FRAME

SIZE

11.63 in. x 3.00 in. x 0.38 in. with 0.25 in. liner

YIELD STRENGTH

110,000 psi

SECTION MODULUS

28.01

RBM (RESIST BEND MOMENT)

3,417,220 in-lb per rail

FRAME CONSTRUCTION

Huck® bolt fastened

PROPELLER SHAFTS

SHAFT

Spicer 1,710 used on front steer axle, all other shafts SPL170

YOKE

Half-round yoke

COOLING SYSTEM

RADIATOR/CAC TYPE

Parallel flow cooling system; radiator and CAC are stacked

RADIATOR CORE

Aluminum fin and tube design, cross-flow type

TRANSMISSION OIL COOLER

Remote mounted oil to water

HYDRAULIC OIL COOLER

Aluminum parallel flow mounted front side of radiator

FAN

9-blade nylon with metal fan ring and fiberglass shroud

FAN CLUTCH

Two-speed with manual override switch

COOLANT HOSES

EPDM

Shut-off valves for heater hoses installed at engine

ELECTRICAL SYSTEM

ALTERNATOR

Prestolite 150-amp brushed

SYSTEM VOLTAGE

12V

CAB ELECTRICAL PROTECTION

80 amp (auto reset) circuit breaker to protect cab electric

STARTING

Delco Remy

LIGHTING

Incandescent

Daylight running lights with override

Auxiliary turn lights in upper hood

BATTERIES

3x 950 CCA @ 0°F each (total 2,850 CCA)

ROUTING/PROTECTION

PVC-shielded chassis harness protection

PAINT

PRIMING

All chassis components primed prior to installation on frame

Electrocoat (Ecoat) used on various parts to provide

corrosion protection compliant with Defense standards

Other components primed with epoxy primer or powder coat

FINISH COAT

Baked polyurethane enamel finish, one color

WHEELS

WHEEL TYPE

Steel hub piloted

Painted

HUBS/DRUMS

Front

Ductile iron

Rear tandem/Auxiliary

Ductile iron

TIRES

TIRE BRAND

Goodyear

REAR TANDEM AXLE			
Supersingle	445/65R22.5 (L) (22.5 x 13 wheel)	Aggressive Tread	Goodyear G278MSD
			Bridgestone L315
		On/Off Hwy Tread	Michelin XZL
			Goodyear G296MSA
	425/65R22.5 (L) (22.5 x 13 wheel)	Aggressive Tread	Bridgestone M854
			Michelin XZY-3
		On/Off Hwy Tread	Goodyear G278MSD
			Bridgestone L315
Dual	11R22.5 (H) (22.5 x 8.25 wheel)	Aggressive Tread	Michelin XZL
			Goodyear G296MSA
		On/Off Hwy Tread	Bridgestone M854
			Michelin XZY-3
	11R24.5 (H) (24.5 x 8.25 wheel)	Aggressive Tread	Goodyear G177
			Bridgestone L320
		On/Off Hwy Tread	Michelin XDY-3
			Goodyear G167A

REAR TANDEM AXLE

MERITOR RT46-160 STANDARD TRACK (46,000 lb rating)

Ratio: 5.38:1

HOUSING THICKNESS

0.50 in. wall

FEATURES

Driver Controlled Inter-Axle Differential (IAD) and Side-to-Side Locks

FRONT STEER AXLE			
445/65R22.5 (L) (22.5 x 13 wheel)	Aggressive Tread	Goodyear G278MSD	
		Bridgestone L315	
	On/Off Hwy Tread	Michelin XZL	
		Goodyear G296MSA	
425/65R22.5 (L) (22.5 x 13 wheel)	Aggressive Tread	Bridgestone M854	
		Michelin XZY-3	
	On/Off Hwy Tread	Goodyear G278MSD	
		Bridgestone L315	

FRONT AXLE ASSEMBLY

SUSPENSION

3 in. leaf spring, double wrap-around front eye

STEERING GEAR

Sheppard Model XD 120 integrated hydraulic power gear

OSHKOSH® SERIES 23K (std with non-LSTA)

Ratio: 5.38:1

OSHKOSH® SERIES 21K (std with LSTA)

Ratio: 5.29:1

	AUXILIARY AXLE (AVAILABLE OPTIONS DEPEND ON TRUCK CONFIGURATION)									
	20 CA		32 CA		44 CA		57 CA			
	196 WB Pusher	209 WB Pusher	195/196 WB Pusher	208 WB Tag	208 WB Pusher	210 WB Pusher(s)	210 WB Tag	234 WB Pushers	234 WB Tag	
Watson AL2200 fixed (20,000 lb)	X	X	X	X	X	N/A	N/A	N/A	N/A	
Hendrickson HLM2 fixed (20,000 lb)	X	X	X	X	X	N/A	N/A	N/A	N/A	
Watson SL-2090TT steerable (20,000 lb)	X	X	X	X	X	N/A	N/A	N/A	N/A	
Watson Alumilite steerable (13,500 lb)	X	X	X	X	X	X	X	X	X	
Hendrickson Compositite steerable (13,500 lb)	X	X	X	X	X	X	X	X	X	
Hendrickson FX fixed (13,500 lb)	X	X	X	X	X	N/A	N/A	N/A	N/A	
Oshkosh Load-Span Tag Axle (LSTA) (13,200 lb)	N/A	N/A	N/A	N/A	N/A	N/A	X	N/A	N/A	
Watson High Lift SL-1185HL (13,500 lb)	N/A	N/A	N/A	X	N/A	N/A	X	N/A	N/A	

REAR SUSPENSION							
	20 CA		32 CA			44 CA	57 CA
	196 WB	209 WB	195 WB	196 WB	208 WB	210 WB	234 WB
Hendrickson Primaax (46,000 lb)	X	X	X	N/A	X	X	N/A
Neway AD246 (46,000 lb)	X	X	X	N/A	X	N/A	N/A
Neway AD252 (52,000 lb)	N/A	N/A	N/A	N/A	N/A	N/A	X
Chalmers 800 (46,000 lb)	N/A	N/A	N/A	X	N/A	X	N/A

PUSHER/TAG AXLE (SINGLE ONLY)						
			20K	13.5K	HLTA	LSTA
			445/65R22.5 (L) (22.5 x 13 wheel)	Aggressive Tread	Goodyear G278MSD	X
Bridgestone L315	X	N/A			N/A	N/A
Michelin XZL	X	N/A			N/A	N/A
On/Off Hwy Tread	Goodyear G296MSA	X		N/A	N/A	N/A
	Bridgestone M854	X		N/A	N/A	N/A
	Michelin XZY-3	X		N/A	N/A	N/A
425/65R22.5 (L) (22.5 x 13 wheel)	Aggressive Tread	Goodyear G278MSD	X	N/A	N/A	N/A
		Bridgestone L315	X	N/A	N/A	N/A
		Michelin XZL	X	N/A	N/A	N/A
	On/Off Hwy Tread	Goodyear G296MSA	X	N/A	N/A	N/A
		Bridgestone M854	X	N/A	N/A	N/A
		Michelin XZY-3	X	N/A	N/A	N/A
11R22.5 (H) (22.5 x 8.25 wheel)	Aggressive Tread	N/A	N/A	N/A	N/A	N/A
		N/A	N/A	N/A	N/A	N/A
		N/A	N/A	N/A	N/A	N/A
	On/Off Hwy Tread	Goodyear G661	X	X	X	X
		Bridgestone R250ED	X	X	X	X
		Michelin XZE	X	X	X	X
255/70R22.5 (H) (22.5 x 8.25 wheel)	Aggressive Tread	N/A	N/A	N/A	N/A	N/A
		N/A	N/A	N/A	N/A	N/A
		N/A	N/A	N/A	N/A	N/A
	On/Off Hwy Tread	Goodyear G661	N/A	X	N/A	N/A
		Bridgestone R250ED	N/A	X	N/A	N/A
		Michelin XZE	N/A	X	N/A	N/A
275/70R22.5 (J) (22.5 x 8.25 wheel)	Aggressive Tread	N/A	N/A	N/A	N/A	N/A
		N/A	N/A	N/A	N/A	N/A
		N/A	N/A	N/A	N/A	N/A
	On/Off Hwy Tread	Goodyear G661	N/A	X	N/A	N/A
		Bridgestone R250ED	N/A	X	N/A	N/A
		Michelin XZE	N/A	X	N/A	N/A

FUEL TANK LOCATION/SIZE				
	RIGHT FRONT	LEFT FRONT	RIGHT REAR	LEFT REAR
20 CA	50, 67, 75	50, 67	N/A	N/A
32 CA	50, 67, 75	50, 67	N/A	N/A
44 CA ≤ 6 axle	N/A	N/A	67, 75	50
44 CA 7 axle	N/A	N/A	50, 70	N/A
57 CA	50, 70	N/A	N/A	N/A

*75 gallon not available on right front with 32 CA DOC cab

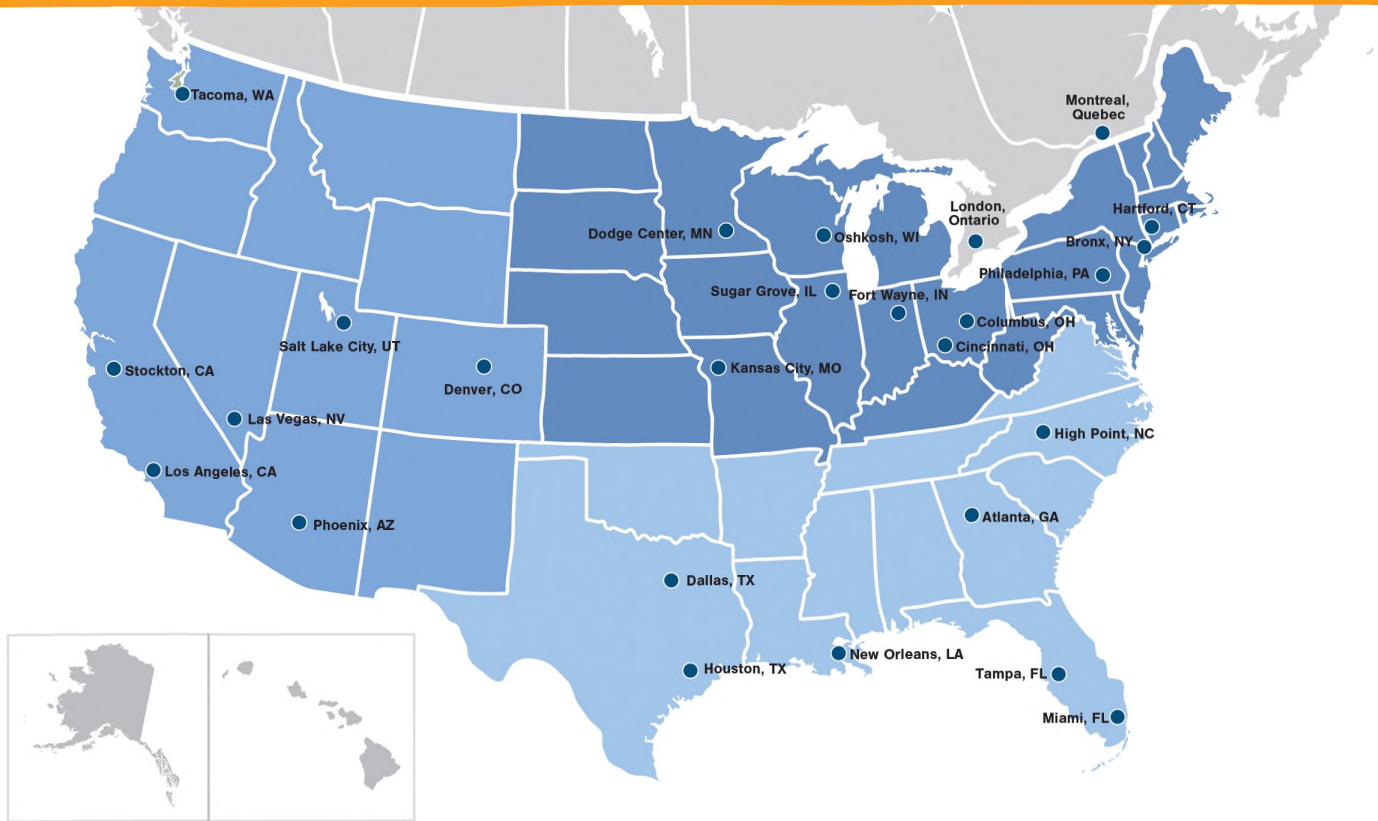

We listen to our customers before, during, and after the sale. Contact our dedicated network of branch offices and service centers. They're strategically located throughout North America. We offer same day parts shipments, 24/7 response, a stock truck program, leasing and financing options. We're standing by to answer questions.

We also have parts and replacement drums for non-McNeilus products that will bring new life to your entire fleet.

McNeilus

An Oshkosh Corporation Company

McNeilus Truck & Manufacturing, Inc.
 524 East Highway St.
 P.O. Box 70
 Dodge Center, MN 55927
 507-374-6321
 Street Smart Parts: 888-686-7278



www.mcneiluscompanies.com



www.StreetSmartParts.com

www.facebook.com/mcneilusconcrete

© 2015 McNeilus Truck & Manufacturing, Inc. McNeilus, the McNeilus logo, and Bridgemaster are registered trademarks of McNeilus Truck & Manufacturing Inc., Dodge Center, MN, USA. Oshkosh and the Oshkosh logo are registered trademarks of Oshkosh Corporation, Oshkosh WI, USA. All other designated trademarks are the property of their respective owners. Specifications, descriptions, and illustrations in this brochure are accurate as shown at the time of publication, but are subject to change without notice. Images may include optional equipment and accessories and may not include all standard equipment.