

# 795F AC

Mining Truck



#### Engine

Engine Model	Cat® C175-16	
Gross Power – SAE J1995	2536 kW	3,400 hp

#### Operating Specifications

Nominal Payload Capacity	313 tonnes	345 tons
Gross Machine Operating Weight (GMW)	570 678 kg	1,257,000 lb

*Courtesy of Machine.Market*

## 795F AC Features

### High Performance Engine

*The Cat® C175-16 engine offers you the perfect balance between power, robust design and economy.*

### Focus on Safety

*Wide access stairways, standard object detection, industry leading dynamic retarding, four corner wet disc brakes and traction control with automatic front brake assist inspire operator confidence.*

### Enhanced Serviceability

*Modular components, grouped service locations and more ground accessible maintenance points translate into more time on the haul road.*

### Reliable AC Electric Drive System

*The Cat AC electric drive power train is 100% Caterpillar designed, integrated and supported.*

### Comfortable Cab

*Operators find that the spacious and quiet cab offers excellent visibility with intuitive, easy to learn controls.*

### Mechanical Drive Legacy

*Using many components from the 797F – the 795F AC emphasis is on durability.*

### Truck Body Options

*Caterpillar designed and built bodies provide you optimal performance and reliability.*

## Contents

Power Train – Cat AC Electric Drive .....	4
Power Train – Engine .....	6
Engine/Power Train Integration.....	7
Cat Braking Systems .....	8
Structures.....	9
Truck Body Systems .....	10
Monitoring System.....	11
Operator’s Station .....	12
Customer Support.....	14
Serviceability .....	15
Safety .....	16
Sustainability .....	17
Specifications.....	18
Standard Equipment.....	23
Optional Equipment.....	24







**For those applications and situations where you prefer an electric drive truck Caterpillar now offers the 795F AC.**

**The Cat AC drive system provides you the best retarding, braking and control in the industry. Designed and manufactured by Caterpillar, the 795 is the first AC electric drive truck that is single sources from one manufacturer and supported by the best dealer network in the industry.**

# Power Train – Cat® AC Electric Drive

Gives you more power to the ground for greater productivity.



## **Why Electric Drive?**

Cat® mechanical drive trucks are the standard of the industry and are favored in most applications. Some customers, however, may prefer electric drive for specific applications and situations.

## **100% Caterpillar**

Designed and manufactured by Caterpillar, the 795 is the first AC electric drive truck that is single sourced from one manufacturer and supported with the best dealer network in the industry. The 795 power train works seamlessly with the C-175 engine and offers you unsurpassed Safety, Serviceability and Performance.

## **Modular Design for Excellent Serviceability**

The modular design allows you easy removal and installation of components. The engine, generator, motors, inverter, grid, and final drives can be removed independently. The rear mounted generator results in better chassis weight balance and is connected to the engine with an isolated drive shaft making generator alignment simple.

## **Superior Control Yields Excellent Operator Confidence**

The Cat AC drive system gives you the best retarding, braking, and control in the industry. Class leading dynamic retarding coupled with full time traction control with automatic front brake blending at all speeds provides operators with superior control and confidence.



## High Voltage – Lower Heat

The Cat AC drive is a high voltage system (2,600 volts) that operates at relatively low current. The result is lower heat generation and longer component life.

## The Cat AC Electric Drive in Propel

The C175-16 diesel engine drives the rear mounted generator through an isolation coupler. The AC power is rectified to a nominal 2,600 volts to form the DC link. The DC link supplies power to the inverter where IGBT's convert the DC signal to 3-phase AC to drive the traction motors. Motor output drives the wheels through a double reduction final drive.

## Cat AC Electric Drive in Retard

During retarding the wheel motors become generators. Motor power is fed back through the DC link. The power is fed to the contactor and chopper circuits and then exhausted through the radial grid. An AC fan blows air across the grid to dissipate the power and control retarding speed.

## Generator/Alternator

The chassis mounted 795F AC traction generator is a three phase, two bearing design. The excitation system is brushless which has longer maintenance intervals than brush type systems.

## Inverter

The inverter uses Mitsubishi Electric IGBT Phase Modules to control the rimpull, direction and speed of the truck. Mitsubishi Electric is the leader in IGBT Technology.

## Traction Motors

Each traction motor is a 3-phase AC induction type. The high voltage, low current motor is mounted to the rear axle and is trolley capable.

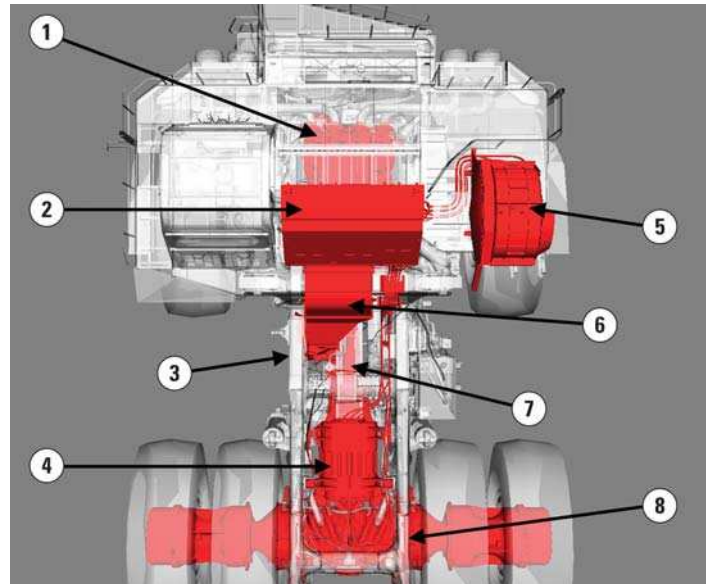

- 1) C175-16 Engine
- 2) Control Power Inverter Cabinet
- 3) Variable Speed Blower
- 4) Alternator/Generator
- 5) Radial Grid
- 6) Cooling Air Duct
- 7) Drive Shaft
- 8) Wheel Motors

## Radial Grid

The radial design grid sits well back on the deck giving operators excellent visibility to the right side. The grid features the highest retarding power in the industry.

## Variable Blower Cooling

Cooling air is provided by a variable flow system that adjusts cooling flow to the needs of the system. This allows maximum power to the motors for excellent propel performance.

## Additional Features

The grid dry function dries the grid quickly in inclement weather. The anti-rollback feature prevents the machine from moving in a direction opposite the operator's intent. Grid power is continuously monitored. Front brake blending prevents grid overheating.

# Power Train – Engine

Power, reliability and efficiency for your most demanding mining applications.

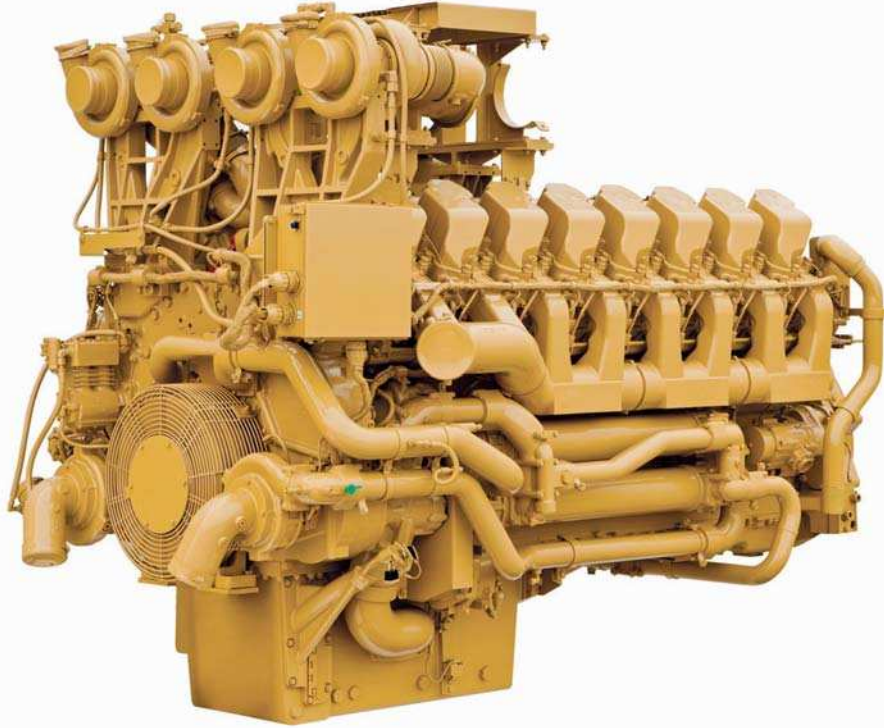

## Cat® C175-16 Engine

The 795F has a Cat C175-16 quad turbocharged air-to-air aftercooled diesel engine that has enhanced power management capability for maximum hauling performance in your most demanding mining applications.

- The C175-16 is a 16-cylinder, four-stroke design that uses long, effective power strokes for optimum efficiency.
- Is compliant with U.S. Environmental Protection Agency emission requirements.
- The variable speed fan directs maximum power to the power train, saving fuel when operating conditions allow.
- High displacement, low rpm rating and conservative horsepower ratings mean you spend more time on the haul roads and less time in the shop.
- The Cat Common Rail Fuel System is an electronically-controlled system senses operating conditions and regulates fuel delivery for optimum fuel efficiency. This precise and flexible fuel system gives the engine the ability to meet emission regulations without sacrificing performance, reliability or durability.
- The flexible core design of the cooling system offers you long life, high durability and ease of service.
- Air start system are ground level serviceable, while the electric start option allows the air system to be totally removed from the truck.
- Your service technicians will appreciate the innovative engine layout. It provides good top end access with the turbo's grouped up front. Internal oil and fuel passages make for a clean layout that is easier to service and reduces engine exchange time at planned replacement. A sight level gauge replaces the dip stick.



## Engine/Power Train Integration

Reduced operating costs through electronically integrated power train components.

### Control Software and Integration

The 795 is simple to learn and simple to operate thanks to a control and integration package that works seamlessly with the trucks power train components. The 100% Caterpillar design allows the software developers full access to all subsystems, which gives the truck excellent operating characteristics.

- Excellent slow speed control for safety within the service areas.
- Excellent throttle response on acceleration to move out of the loading or dump areas.
- Dynamic retarding with automatic front brake assist.
- Automatic traction control in forward and reverse.

### Cat Data Link

All computer systems are linked to:

- Optimize power train performance.
- Increase reliability and component life.
- Reduce operating costs.



# Cat Braking Systems

Superior braking control lets operators focus on productivity.

## Industry Leading Dynamic Retarding

The radial grid is rated at 4.75 MW (6,365 hp) – allowing you excellent control of the truck speed in long retarding applications. The radial design is light, efficient and quiet.

## Four Corner Oil Cooled Brakes for Additional Retarding

In addition to class leading dynamic retarding – Cat four corner, oil cooled service brakes give additional retarding capability. These are the same sized brakes used on the 797. The 795 offers exceptional non-fade braking and supplemental retarding at all speeds.

## Traction Control with Automatic Front Brake Blending

If the truck senses any slip – the front brakes will automatically engage. The addition of front braking keeps the truck moving in the intended direction and the operator in control. This blended braking capability is an industry first and has been enthusiastically received by operators. In addition, the operator can select full time front brake blending.

## Automatic Retarding Control

Operator controlled – ARC engages automatically and maintains speed consistently. A simple toggle switch is used to adjust retarding speed.

## Control to Prevent Exceeding Retarding Capability

Built into the software is a Grid Thermal Calculator that constantly monitors power to the grid. When dynamic retarding capability is exceeded the mechanical brakes are blended in automatically. This will continue as long as necessary. Often this is a transient condition. The operator is alerted to take corrective action if this continues. The brake blending is smooth and seamless.



## Brake Design

Cat oil cooled brakes are designed with large discs and plates for reliable and adjustment free operation. They are enclosed and sealed to prevent contamination and provide long life.

## Parking Brake

The oil cooled, spring applied, hydraulically released parking brake on all wheels provide superior parking capability on grades up to 15%.

## Anti-Rollback

Automatically applies service brakes to prevent the truck from rolling from a stop opposite the intended direction of travel.

## Reverse Shift Inhibit

Ensures reverse propulsion is not applied when the machine is moving forward.





### Box Section Design

The 795F AC frame uses a box-section design, incorporating forgings and castings in high stress areas with deep penetration continuous wrap-around welds to resist fatigue from racking loads.

- **Steel Structures** – Mild steel used throughout frame provides flexibility, durability and resistance to impact loads and allows for field repairs with common weld practices.
- **Castings** – Castings have large radii to dissipate stress in areas of high stress concentration. Castings allow welds to be placed in lower stress areas for longer frame life.

## Structures

Superior Cat structures in the 795F AC give you durability and long life.

### Integral Four-Post ROPS Cab

Resiliently mounted to the main frame to reduce vibration and sound, the integral ROPS is designed as an extension of the truck frame.

### Suspension System

Designed to dissipate haul road and loading impacts for longer frame life and a more comfortable ride.

- **Durable Design** – Large diameter cylinders with nitrogen over oil design for long life with minimal maintenance.
- **Front Cylinders** – Have preset caster and camber and are mounted to the frame. They also serve as steering king pins for a tight turning radius.
- **Rear Cylinders** – Allow axle oscillation and absorb bending and twisting loads from the haul roads, reducing stress on the main frame.

### Four-bar Link Rear Suspension

Directs a more even load distribution into the main frame – operators report a more secure feeling of the truck being well connected and under control.

### Steering System

Single tie rod steering system is simpler and requires less maintenance.

# Truck Body Systems

Designed and built for rugged performance and reliability.

## Cat Bodies for Cat Trucks

Integral to the truck the body is designed to fit with the chassis and work as part of the truck system. Each body is sized to meet the payload requirements without compromise to vehicle balance, braking or control.

## Cat Body Choices

Body options include the popular MSD II (Mine Specific Design) and Gateless Coal Bodies. Liner options fit the body to the application.

- **MSD II Body** – Based on the mine site evaluation of your mine, the body is sized and configured to meet the specific needs dictated by fragmentation, abrasion, cohesion, and the loading tool. This body achieves an excellent balance of payload and durability.
- **Gateless Coal Body** – Eliminating problematic tail gates – the Gateless Coal Body is intended for dedicated coal haulage.





# Monitoring System

Keeping your production at peak levels.



## VIMS™ 3G Monitoring System

Provides operator critical health and payload information in real-time to keep the 795 performing at optimum levels. VIMS is able to monitor information from all vehicle systems. 10 different machine parameters can be viewed at once. Data can be downloaded easily by Service Technicians for troubleshooting, planning and lowering costs.

### Advisor Display

The Advisor display provides real-time performance, maintenance and diagnostic data to the operator or service technician. A large number of machine parameters can be viewed including temperature, pressure, speed, and payload.

### Payload Management

Information is available to manage payloads to improve fleet effectiveness and loading tool match and to prevent overloading to help extend component life and lower operating and maintenance costs.

### External Payload Indicators

Standard external lights or optional digital display to help loading tool operator reach payload target and minimize overloading.

### Road Analysis Control

Optional system measures frame rack, bias and pitch to help identify haul road problems so they can be repaired. This leads to improved cycle time, component lives and fuel efficiency.

### VIMSpC

An Off-board software reporting program that allows your service personnel to download a complete record of machine health and productivity data. Health and payload reports can be generated for more effective machine management, which reduces downtime and lowers operating costs.

### VIMS Supervisor

Optional software allows your mine personnel to easily manage and interpret VIMS data for optimum fleet management and productivity.



# Operator's Station

Ergonomically designed for all-day comfort, control and productivity.







## Operator Environment

You now have the choice to select a cab with the features you desire. There are three choices based on popular arrangements. Available offerings include a Standard Cab, Deluxe Cab or Deluxe Cold Weather Cab.

## Enhanced Operator Awareness

The standard Cat Detect system uses Radar and Cameras to give the operator audible alarms and visual awareness of detected objects at start up and low speeds.

## Ergonomic Layout

To minimize operator fatigue and maximize productivity the all new F-Series operator station is ergonomically designed for total machine control in a comfortable, productive and safe environment. Controls, levers, switches and gauges are positioned for ease of use.

## Viewing Area

Designed for excellent all-around visibility and clear sight lines to the haul road, the large viewing area offers exceptional visibility, allowing the operator to maneuver with confidence for high productivity. The air cleaners have been relocated to the front of the truck, allowing the operator increased visibility.

- 1) Air suspension seat with three-point operator restraint
- 2) Hoist lever
- 3) Secondary brake pedal
- 4) Advisor display
- 5) Adjustable steering column
- 6) Vehicle directional control
- 7) Gauges
- 8) Storage compartment
- 9) Full size trainer seat
- 10) Electric powered operator window
- 11) Turn signal and wiper controls
- 12) Ventilation controls
- 13) Four post ROPS
- 14) Cat Detect monitor
- 15) MineStar Monitor (optional)
- 16) Cup holder
- 17) Dome lights



# Customer Support

Keeping you running with the most experienced dealer network.

## Commitment to Meet Your Needs

Cat dealer 24/7 support offers solutions, services and products to help you lower costs, enhance productivity and manage your fleet anywhere in the world. Expert technicians have the knowledge, experience, training, parts and tooling to keep your 795 running at high availability.

## Product Support

Caterpillar supports the 795 with a worldwide network of parts distribution, dealer service centers and technical training facilities. Our global dealer network is ready to meet your support needs around the clock and around the world.

## Service Support

Cat dealers offer a wide range of service plans to help maximize your uptime and return on your investment, including:

- Preventive Maintenance Programs
- Diagnostic Services such as Scheduled Oil Sampling and Technical Analysis
- Rebuild and Remanufactured Product Options
- Customer Support Agreements

## Application Awareness

Application and site-specific factors such as material density, loading practices, payload, speed, grade and haul road design and maintenance influence the cost to operate and maintain your haulage fleet. Your Cat dealer can provide help in understanding the effects application factors and operating practices have on maintenance and operating costs. They also offer training to help operators improve productivity, decrease downtime, reduce operating costs and enhance safety.



# Serviceability

Reduced maintenance time results in more productivity.



## Modular Design

Major components can be serviced individually with minimal removal and installation time. Work platforms and step/stairs are located in key service areas. Rear mounted generator is separate from the engine and can be removed without removing the body – wheel motors are separate from final drives. Engine turbos (4) are grouped in the front of the engine.

## Ground Level Access

Grouped service points allow convenient access to tank levels, filters, drains and S-O-S<sup>SM</sup> oil sampling ports. The battery box, Auto Lube system and VIMS data port are also ground level accessible.



## Servicing Ease

Bumper Service Center features lock out tag out, battery box and disconnects for battery and power train. Chassis filters for steering, braking and hoist systems are designed for 1,000 hour life.

## Sealer Electrical Connectors

Electrical connectors are sealed to lock out dust and moisture. Harnesses are braided for protection. Wires are color coded for ease of diagnosis and repair.

# Safety

Designed with safety as the first priority.

## Product Safety is a Commitment

Caterpillar is concerned about your safety. We continue to be the industry leader in proactive development of machines and features that exceed safety standards.

## Cat Detect System

Knowing what's around your 795F AC at all times is important. The Cat Detect system is factory installed as standard equipment on 795F AC Mining Trucks. The full Cat Detect system, RADAR AND CAMERA, provides both audible and visual indications of detected objects. This system uses a combination of short and medium range radars which surround the machine, along with cameras on each side to allow the operator to confirm the detected object. The cameras supplement the radar alerts and are selectable by touch screen menus through an intuitive interface.

## Integrated Blended Braking with Traction Control

Front brakes are automatically blended when slip is sensed to give excellent control in slippery conditions. The operator can also choose full time front brake blending. Front brakes are also automatically blended when dynamic retarding approaches 90% of its capacity. Front brake blending yields superior control and high operator confidence.

## Access/Egress

Standard 60 mm (24") stairways with an optional Powered Access Stairway allow easy and safe access and egress.

## GVW within Tire Manufacturers Guidelines

At rated GVW the 795F AC is within tire loading guidelines for approved 56/80R63 and 59/80R63 tires.







# Sustainability

A variety of features improve sustainability in areas of decreasing waste, extending component life and lowering emissions levels.

## **Sustainability Features**

The 795F AC Mining Truck offers continuous rear axle filtration, extended life filters and extended maintenance intervals which aid in decreasing the amount of waste contributed to our environment.

## **Remanufacturing Options**

Cat trucks are designed to be rebuilt and have logged over 100,000 frame hours in many applications. Components are designed to be remanufactured for multiple service lives.

## **Engines with Advanced Technology**

Engines with advanced technology contribute less emissions to the environment while maintaining fuel efficiency.

## **Advanced Surface Technology (AST)**

Advanced Surface Technology (AST) is a replacement for hard chrome coatings on some steel parts, including suspension and hoist cylinder rods. This technology improves wear resistance and reduces repair time. Chrome has been eliminated to reduce environmental impact.

# 795F AC Mining Truck Specifications

## Engine

Engine Model	Cat C175-16	
Gross Power – SAE J1995	2536 kW	3,400 hp
Bore	175 mm	6.9 in
Stroke	220 mm	8.7 in
Displacement	85 L	5,187 in <sup>3</sup>

- Power ratings apply at 1,800 rpm when tested under the specified condition for the specified standard.
- Ratings based on SAE J1995 standard air conditions of 25° C (77° F) and 99 kPa (29.61 Hg) dry barometer. Power based on fuel having API gravity of 35 at 16° C (60° F) and an LHV of 42 780 kJ/kg (18,390 Btu/lb) when engine used at 30° C (86° F).
- No engine derating required up to 3203 m (10,500 ft) altitude.
- Compliant with U.S. Environmental Protection Agency Tier 2 emission standards.

## Weights – Approximate

Gross Machine Operating Weight (GMW)	570 678 kg	1,257,000 lb
Chassis Weight	202 270 kg	445,524 lb
Body Weight Range	38 500- 54 500 kg	84,900- 120,000 lb

- GMW depends on tire selection. Consult your tire manufacturer for maximum loaded top speed.
- Chassis weight with 100% fuel, hoist, body mounting group, rims and tires.
- Body weight varies depending on how body is equipped.

## Operating Specifications

Nominal Payload Capacity	313 tonnes	345 tons
Top Speed – Loaded	64 km/h	40 mph
Steer Angle	34 degrees	
Turning Diameter – Front	34 m	112 ft
Turning Circle Clearance Diameter	38.7 m	127 ft

- Refer to the Cat® Mining Truck 10/10/20 Overload Policy (AEXQ0250) for maximum gross machine weight limitations.

## Final Drives

Total Reduction Ratio	35:1
-----------------------	------

## AC Drive System

Generator/Alternator	Brushless, remote mounted, dual bearing
Controls	IGBT Inverter Technology, air cooled, pressurized cabinet with filtration
Wheel Motor	Rear axle mounted Cat AC induction
Cooling System	Variable speed, hydraulic cooling system

## Suspension

Effective Cylinder Stroke – Front	293 mm	11.5 in
Effective Cylinder Stroke – Rear	141 mm	5.6 in
Rear Axle Oscillation	±4.8°	

## Body Hoists

Pump Flow – High Idle	935 L/min	247 gal/min
Relief Valve Setting – Raise	24 500 kPa	3,553 psi
Body Raise Time – High Idle	19 Seconds	
Body Lower Time – Float	20 Seconds	
Body Power Down – High Idle	17.5 Seconds	

- Twin, two-stage hydraulic cylinders mounted inside main frame; double-acting cylinders in second stage.
- Power raise in both stages; power down in second stage.
- Automatic body-lower modulation reduces impact on frame.

## Braking System

Oil Cooled Brakes – Retarding Capable at All Speeds		
Outside Diameter	1067 mm	42 in
Brake Surface – Front	132 258.4 cm <sup>2</sup>	20,500.09 in <sup>2</sup>
Brake Surface – Rear	198 388 cm <sup>2</sup>	30,750.2 in <sup>2</sup>
Standards	J-ISO 3450 JAN88, ISO 3450:1996	

## Electric Retarding

Radial Grid Design with Brushless AC Fan Motor	4750 kW (6,370 hp) rated power	
Dynamic Retarding Power	4750 kW	6,370 hp
Blended Four Corner Retarding	Standard	



## Weight Distributions – Approximate

Front Axle – Empty	48%
Rear Axle – Empty	52%
Front Axle – Loaded	33%
Rear Axle – Loaded	67%

## Capacity – MSD II – 100% Fill Factor

Struck	121.5-211 m <sup>3</sup>	159-276 yd <sup>3</sup>
Heaped (SAE 2:1)	181-252 m <sup>3</sup>	237-330 yd <sup>3</sup>

- Contact your local Cat dealer for body recommendations.

## Service Refill Capacities

Fuel Tank	3596 L	950 gal
Fuel Tank (optional)	7192 L	1,900 gal
Cooling System	1100 L	291 gal
Crankcase	310 L	82 gal
Final Drives, Each	341 L	90 gal
Steering Tank	210 L	55.5 gal
Steering System (Includes Tank)	300 L	79 gal
Brake/Hoist Hydraulic Tank	508 L	134.2 gal
Brake/Hoist System (Includes Tank)	1500 L	396.3 gal

## Tires

- 56/80R63
- 59/80R63
- Productive capabilities of the 795F AC truck are such that, under certain job conditions, TKPH (TMPH) capabilities could be exceeded and, therefore, limit production.
- Caterpillar recommends the customer evaluate all job conditions and consult the tire manufacturer for proper tire selection.

## ROPS

### ROPS Standards

- ROPS (Rollover Protective Structure) for cab offered by Caterpillar meets ISO 3471:2008 ROPS criteria.
- FOPS (Falling Objects Protective Structure) meets ISO 3449:2005 Level II FOPS criteria.

## Sound

### Sound Standards

- The operator sound pressure level measured according to work cycle procedures specified in ISO 6394 and 6396 is 76 dB(A) for cab offered by Caterpillar when properly installed and maintained and tested with doors and windows closed.
- Hearing protection may be needed when operating with an open operator station and cab (when not properly maintained or doors/windows open) for extended periods or in a noisy environment.

## Steering

Steering Standards	SAE J1511 OCT90 ISO 5010:1992
--------------------	----------------------------------

- Gross Machine Operating Weight is 570 166 kg (1,257,000 lb).

# 795F AC Mining Truck Specifications

## Dimensions

All dimensions are approximate.

Shown with 220 m<sup>3</sup> (288 yd<sup>3</sup>) MSD II Body.

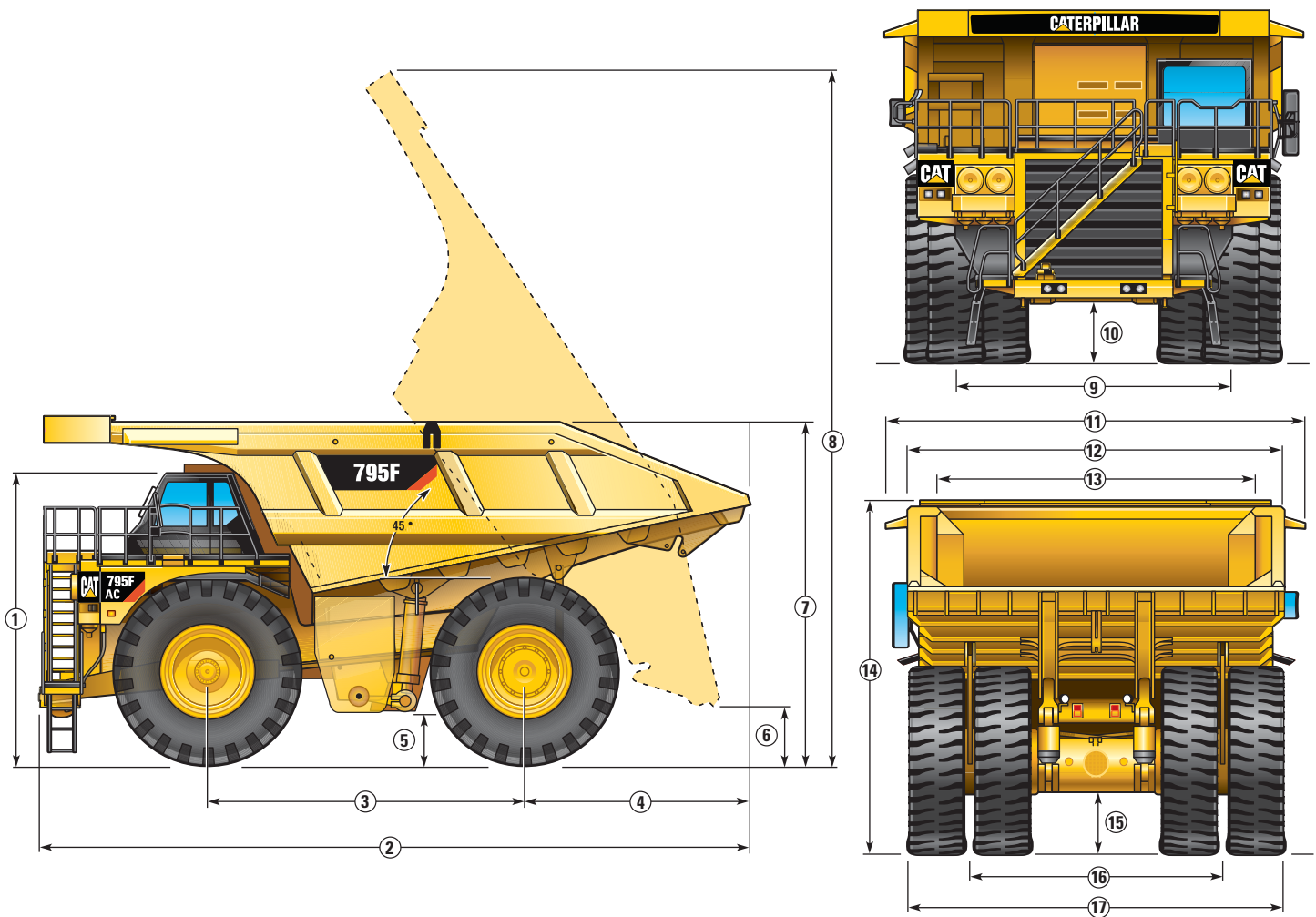

1 Height to Top of ROPS	6327 mm	20 ft 9 in
2 Overall Length	15 146 mm	49 ft 9 in
3 Wheelbase	6725 mm	22 ft 1 in
4 Rear Axle to Tail	4411 mm	14 ft 6 in
5 Ground Clearance	750 mm	2 ft 6 in
6 Dump Clearance	1664 mm	5 ft 6 in
7 Loading Height – Empty	7040 mm	23 ft 2 in
8 Overall Height – Body Raised	15 445 mm	50 ft 8 in
9 Centerline Front Tire Width	6235 mm	20 ft 6 in
10 Engine Guard Clearance	1208 mm	4 ft 0 in
11 Overall Canopy Width	9449 mm	31 ft 0 in
12 Outside Body Width	8970 mm	29 ft 5 in
13 Inside Body Width	7856 mm	25 ft 9 in
14 Front Canopy Height	7800 mm	25 ft 8 in
15 Rear Axle Clearance	1016 mm	3 ft 4 in
16 Centerline Rear Dual Tire Width	5675 mm	18 ft 8 in
17 Overall Tire Width	8966 mm	29 ft 6 in



## 795F AC Gradeability/Speed/Rimpull\*

To determine gradeability performance: Read from gross weight down to the percent of total resistance. Total resistance equals actual percent grade plus 1% for each 10 kg/t (20 lb/ton) of rolling resistance. Usable rimpull will depend upon traction available and weight on drive wheels.

- Typical Field Empty Weight
- ..... Gross Machine Operating Weight  
570 166 kg (1,257,000 lb)

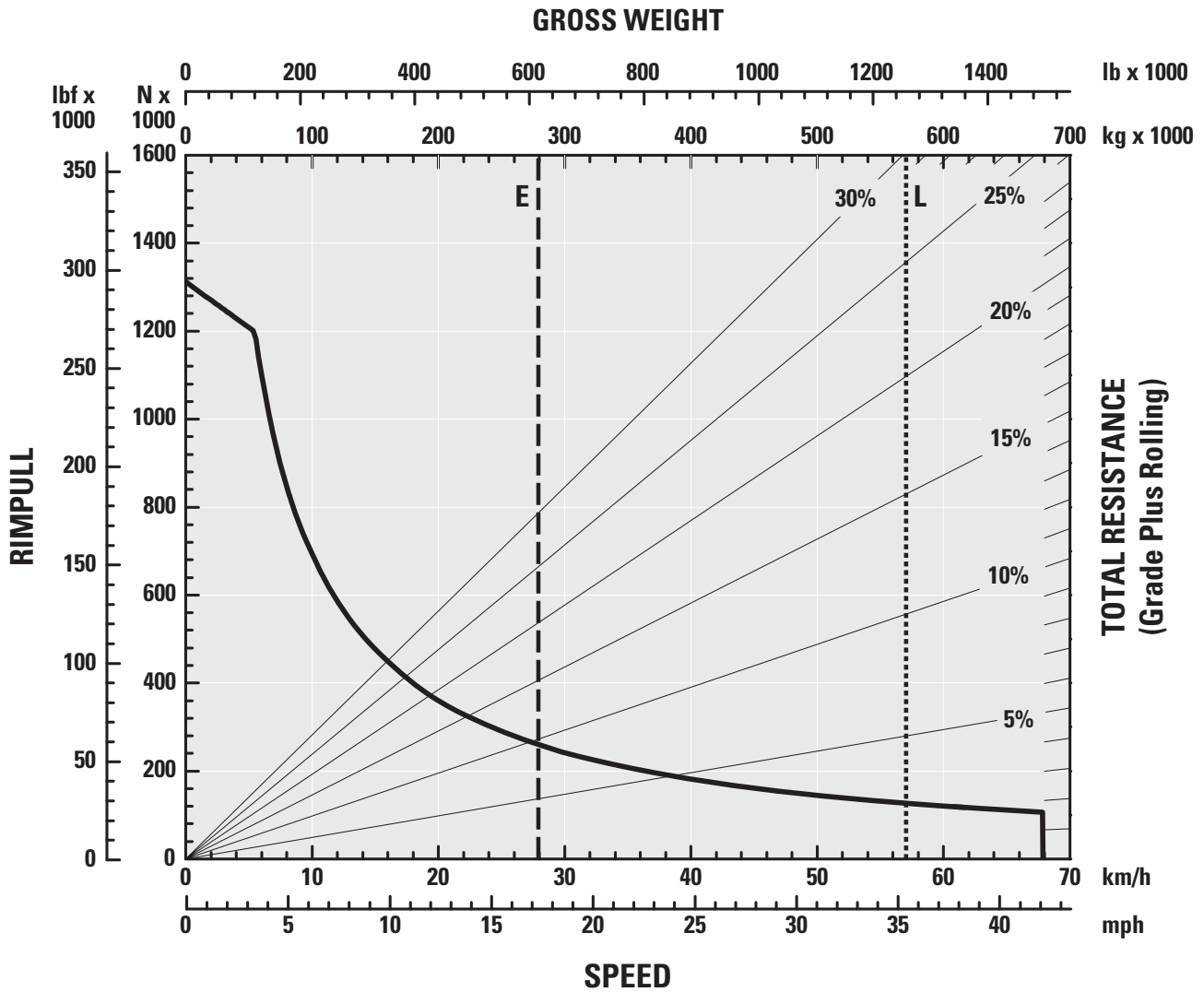

E – Empty  
L – Loaded

\*At sea level, 30° C (86° F).

Contact factory for performance estimates based upon site specific temperatures and altitudes.

# 795F AC Mining Truck Specifications

## 795F AC Standard Retarding – Continuous\*

To determine retarding performance: Read from gross weight down to the percent effective grade. Effective grade equals actual % grade minus 1% for each 10 kg/t (20 lb/ton) of rolling resistance. The following charts are based on these conditions: 32° C (90° F) ambient temperature, at sea level, with 56/80R63 tires.

- — — — — Typical Field Empty Weight
- ..... Gross Machine Operating Weight  
570 166 kg (1,257,000 lb)

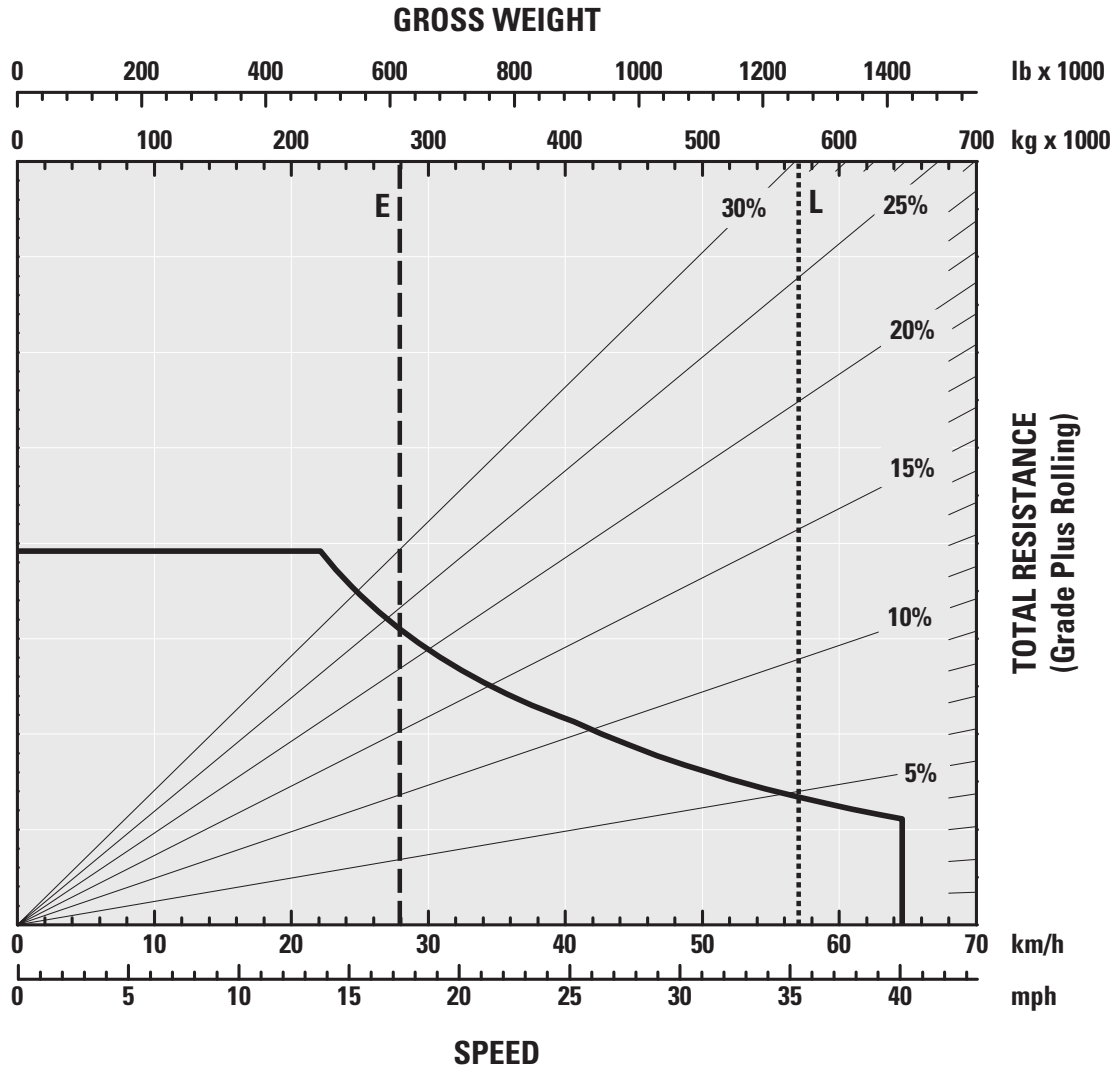

- E – Empty
- L – Loaded

\*At sea level, 30° C (86° F).

Contact factory for performance estimates based upon site specific temperatures and altitudes.

## Standard Equipment

Standard equipment may vary. Consult your Cat dealer for details.

### ELECTRICAL

- Alarm, Back-up
- Brushless Alternator, 150 ampere
- Batteries, 210-amp hour, low maintenance, 12-volt (2)
- Converter, 12-volt electrical
- Electrical System, 24-volt, 10, 15 and 20 amp
- Battery Charge Receptacle
- Lighting System
  - Back-up and Hazard Lights
  - Directional Signals (front and rear LED)
  - Front Stair Access/Service Deck
  - Stop/Tail Lights (LED)
  - Engine Compartment
  - VIMS, Blue Light (LED)
  - Headlights, with Lo-Hi Beam Selector

### OPERATOR ENVIRONMENT

- Air Conditioner with Automatic Climate Control
- 12-volt DC Power Supply (3)
- Coat Hook
- Cup Holder
- Diagnostic Connection Port
- Dome Courtesy Light
- Map Lights (2)
- Entertainment Radio Ready
  - 20 amp Switched/10 amp Memory Converter, Speakers and Wiring Harnesses
- Gauge/Indicators
  - Gauge Panel:
    - Drive Train (system temperature)
    - Brake Oil Temperature
    - Engine Coolant Temperature
    - Fuel Level
    - Torque Converter Oil Temperature
  - Electric Engine Control Fault Indicator
  - Electric Hour Meter
  - Speedometer
  - Tachometer
- Heater/Defroster, 10 310 kCal (40,912 BTU)
- Hoist, Body Control (electric)
- Horn (2)
- Cat Detect (Radar and Camera) System
- Mirrors, Right and Left
- ROPS Cab, Insulated/Sound Suppressed

- Seat, Operator, Air Suspension
- Seatbelt, Operator, Three Points, Retractable
- Seatbelt, Trainer, Two Points, Retractable
- Stairway and Walkway Access, 600 mm (23.6 in)
- Steering Wheel, Tilt, Padded, Telescopic
- Storage Compartments
- Tinted Glass
- Transmission Gear Indicator
- VIMS Message Center with Advisor
- Window, Operator, Electric Powered
- Windshield, Wiper Intermittent Control and Washer

### POWER TRAIN

- Cat C175-16 Tier 2 Emissions Compliant Engine
  - Air Cleaner with Precleaner (4)
  - Air-to-Air Aftercooler (ATAAC)
  - Automatic Starter Protection
  - Ether Starting Aid (automatic)
  - Multi-Point Oil Pressure Sensing
  - Turbocharging (4)/Aftercooled
- Braking System
  - Automatic Retarder Control, Adjustable
  - Brake Release Motor (towing)
  - Engine Overspeed Protection
  - Extended Life Brake Disc Material
  - Oil-cooled, Multi-disc (front and rear)
    - Service, Retarding, Parking, Secondary
  - Park Brake Integrated with Gear Selector
  - Secondary, Emergency
- Cat AC Drivetrain
  - IGBT controlled AC induction motors
  - AC generator
  - AC cooled radial grid
  - Body-up Reverse Neutralizer
  - Body-up Shift Inhibitor
  - Directional Shift Management
  - Neutral Coast Inhibitor
  - Neutral Start Switch
  - Programmable Top Speed
  - Reverse Shift Inhibitor
- Pre-lubrication/Engine
- Rear Axle Continuous Lubrication/Filtration

### OTHER STANDARD EQUIPMENT

- Air Starter, Turbine
- Air System Dryer
- Automatic Lubrication System
- Aux “Buddy” Dumping Quick Connect
- Aux Steering Quick Connect (towing)
- Blended Retarding System
- Driveline Guards
- Exhaust
- Fuel Tank, 3596 L (950 gal)
- Fast Fill Fuel System
- Fuel Filter with Water Separator
- Ground Level Battery Lockout
- Ground Level Engine Shut-down
- Ground Level Engine Start Lockout
- Ground Level Machine Lockout
- Ground Level Transmission Lockout
- Ground Level VIMS Data Port
- Hi-speed Crankcase Oil Change
- Hydraulic Filters, 1,000 hour
- Payload Indicator Lights
- Reservoirs (2 separate)
  - Brake/Hoist, Steering/Fan
- Rock Ejectors
- Service Points, Ground Level
- Sight Level Gauges for Hydraulic/Engine Oil
- S-O-S Sample Ports
- Supplemental Steering (automatic)
- Tie Down Eyes
- Tow Hooks and Pin (front)
  - Tow Pin (rear) (Empty truck only)
- Traction Control System
- Vandalism Protection Locks
- Vital Information Management System (VIMS)
  - Includes VIMS Payload Monitor with MAX Payload and Speed Manager
    - VIMS 3G requires download cable 305-5528 VIMS 3G Connect PC software (reference media number EERP2001) and VIMS PC software JERD2175. Supplemental software “VIMS Supervisor” YERA1403. Order separately. Computer not provided.

### ANTIFREEZE

- Extended Life Coolant to –35° C (–30° F)



# 795F AC Optional Equipment

## Optional Equipment

Optional equipment may vary. Consult your Cat dealer for details.

- Access Platform, Rear Part of Chassis
- Additional Lighting
- Additional Retarding for Downhill Hauls
- Air Start, Turbine, TDI
- Antifreeze/Coolant Protects to  $-50^{\circ}\text{C}$  ( $-58^{\circ}\text{F}$ )
- Body
  - MSD II Body:
    - Body, MSD II, 181 m<sup>3</sup> (237 yd<sup>3</sup>)
    - Body, MSD II, 220 m<sup>3</sup> (288 yd<sup>3</sup>)
  - MSD II Body Attachments:
    - Extensions, 400 mm (~15 in) 206 m<sup>3</sup> (270 yd<sup>3</sup>); Fits 181 m<sup>3</sup> (237 yd<sup>3</sup>) body
    - Extensions, 395 mm (~15 in) 237 m<sup>3</sup> (310 yd<sup>3</sup>); Fits 220 m<sup>3</sup> (288 yd<sup>3</sup>) body
    - Extensions, 550 mm (~21 in) 248 m<sup>3</sup> (324 yd<sup>3</sup>); Fits 220 m<sup>3</sup> (288 yd<sup>3</sup>) body
    - Extensions, 675 mm (~26 in) 252 m<sup>3</sup> (330 yd<sup>3</sup>); Fits 220 m<sup>3</sup> (288 yd<sup>3</sup>) body
  - Films, Body
  - Gateless Coal Body:
    - Body, Gateless Coal, 352 m<sup>3</sup> (460 yd<sup>3</sup>)
  - Gateless Coal Body Attachments:
    - Extensions, 440 mm (~17 in) 382 m<sup>3</sup> (500 yd<sup>3</sup>)
    - Extensions, 875 mm (~34 in) 413 m<sup>3</sup> (540 yd<sup>3</sup>)
    - Extensions, 1060 mm (~41 in) 428 m<sup>3</sup> (560 yd<sup>3</sup>)
- Body Heat
- Body Mounting Groups
  - MSD II Body
  - Gateless Coal Body
- Brake Wear Indicator Gauge
- Cabin Air Precleaner
- Camera Only Vision System
- Cat Comfort Air Suspension Trainer Seat
- Cat Comfort Heated Operator Seat
- Electric Powered Window, Right Side
- Electric Starting System
- Engine (High Altitude)\*
- Engine Coolant and Oil Heater for Cold Weather Starts
- Engine Delay Shutdown Timer
- Filtration, Final Drive Oil Cooler
- External Digital Payload Display
- Fuel Tank (7192 L/1,900 gal)
- Gauge, Brake Wear Indicator
- Ground Access, Powered
- Ground Access, Fixed, Reversed
- Ground Access, Powered, Reversed
- Heated Mirrors, RH
- Heated Mirrors, LH
- High Intensity Discharge (HID) Lighting (front and rear)
- Horn, Air or Electric, LH or RH
- Instructions (ANSI or ISO)
- Language Monitors – English, Spanish, French, German, Italian, Portuguese, Dutch, Norwegian, Swedish, Estonian, Latin, Lithuanian, Slovakian, Slovenian, Greek, Roman, Russian, Polish, Czech, Hungarian, Icelandic, Finnish, Danish, Thai, Indonesian, Vietnam, Malaysian, Chinese, Japan, Korean, Croat, Serbian, Mongolian, Hebrew, Turkish, Arabic
- Machine Access, Reversed
- Portable Fire Extinguisher
- Retractable Front Sun Visor
- Road Analysis Control (RAC)
- Seat, Full Size, Trainer
- Service Center, Pressurized System
- Service Center, Non-Pressurized System
- SL-V Grease Injectors
- Wheel Chocks
- Wheels, Wedge, 1041 mm (41 in)

\*For certain markets only.









For more complete information on Cat products, dealer services, and industry solutions, visit us on the web at [www.cat.com](http://www.cat.com)

© 2013 Caterpillar Inc.  
All rights reserved

Materials and specifications are subject to change without notice. Featured machines in photos may include additional equipment. See your Cat dealer for available options.

CAT, CATERPILLAR, SAFETY.CAT.COM, their respective logos, "Caterpillar Yellow" and the "Power Edge" trade dress, as well as corporate and product identity used herein, are trademarks of Caterpillar and may not be used without permission.

AEHQ6882-01 (02-2013)  
Replaces AEHQ6882



*Courtesy of Machine.Market*