

# **LIEBHERR RL 52 Litronic**

*80 tons lift capacity pipelayer*



**Liebherr Diesel engine - 243 kW (330 HP)**

**D8N chain, single grouser track pads 914/711 mm**

**ROPS canopy or ROPS cabin with heater / air-conditioning**

**7.000 mm boom made of highly resilient, grain refined steel**

**80 tons lift capacity - Hydraulic driven hoist winch**

**Operating weight 52.300 kg - Ground pressure 0,89 kg/cm<sup>2</sup>**

**Extractable counterweight 12.193 kg (removable weight 9.289 kg)**

**Hydr. drive for pipe facing machine and welding generator (optional)**

# Technical Description

## Pipe Layer

**RL 52**  
Litronic®

**Engine output 243 kW/330 HP**  
**Max. lift capacity 80 tons/176,400 lb**  
**Operating weight 52.3 tons/115,322 lb**



# LIEBHERR

The Better Machine.



## The decisive economical factors of the RL 52 Litronic:

### 1. The construction machine engine:

The heart of the RL 52 pipe layer is the Liebherr diesel engine, with reduced emissions, specially designed for construction site applications. In addition to a high level of reliability, the engine also offers exemplary performance and it does so while achieving a low level of fuel consumption previously unattained. The pipe layer's cooling system is specially adapted to high ambient temperatures. The cooler's extremely large distance between ribs provides for high reliability and longer periods between service intervals.

### 2. The hydrostatic travel drive:

The outstanding characteristic of the pipe layer is its modern drive concept. In contrast to conventional systems, this drive offers decisive advantages in pipeline construction, like e.g.

- Stepless speed regulation
- Single lever operation
- Constant drawbar force on both tracks preventing the machine from sinking on soft ground
- Exact positioning of the pipe due to the ability to turn on the spot
- Maximum drawbar force is available to the operator as soon as the machine starts travel
- Low operating costs due to wear-free brakes and a low number of drive components.

### 3. The innovative undercarriage:

The asymmetrical undercarriage makes it possible to work specially on the load side while ground pressure is reduced considerably. At the same time, the machine's off-centered center of gravity, provides the pipe layer unimagined lift force.

### 4. The simple and comfortable operation:

Operating elements, proven in on site experience, make the Liebherr pipe layer remarkable. All travel functions, all boom functions as well as the load hook are controlled by one joystick respectively. Optimal for safe and easy handling of the machine.

### 5. The economical working attachments:

Above all, the pipe layer's working attachments are convincing due to their functionality with:

- the hydraulically driven winch
- the hydraulically adjustable boom
- the standard working hydraulics can be used to drive a pipe facing machine or a welding generator.



The boom can be adjusted precisely and without sudden jerks with a hydraulic cylinder.



The hydraulically driven cable winch offers stepless and precise control of the load hook. Lowering the load occurs while stress flows constantly. If the cable winch is not being used, the automatic safety brake is applied immediately and thus guarantees secure holding of the load.



The pipe layer can also be equipped both with a canopy and a fully enclosed operator's cab.

# The RL 52 Pipe Layer: Versatile, precise and economical.



## Diesel Engine

Liebherr-Diesel Engine	D 9406 TI-E
Rating per ISO 9249	243 kW (330 HP) at 1800 RPM
Displacement	13 l / 794 cu.in.
Bore/stroke	135/150 mm / 5.31"/5.91"
Design	6 cylinder in-line engine, water-cooled, turbocharged, intercooled
Injection	direct fuel injection with in-line injection pump, mechanical governor
Fuel filter	pre-cleaner with water separator and fine filters
Lubrication	pressurized lube system with full flow filter and integrated oil cooler, deep oil pan for inclinations, engine lubrication to an inclination of up to 45° to each side
Operating voltage	24 V
Alternator	80 Amp.
Starter	9 kW (12 HP)
Central fuse box	40 A
Batterie	170 Ah



## Travel Drive

Design	closed-loop hydrostatic drive, each track is driven by one variable flow swash plate-type pump and one variable displacement motor
Pump flow	max. 425 l/min / 112.2 gal/min
Max. pressure	adjusted to 420 bar / 6090 PSI
Travel speed	0 - 11 km/h / 0-6.8 mph infinitely variable, forward and reverse
Steering	hydrostatic
Service brake	hydrostatic
Parking/emergency brake	automatic multi disc brake in final drives
Cooling system	hydraulic oil cooler with separate cooling circuit with gear pump and front mounted cooler
Filter system	cartridge fine filters in the cooling circuit
Final drive	2-stage planetary reduction gear

Drawbar pull kN

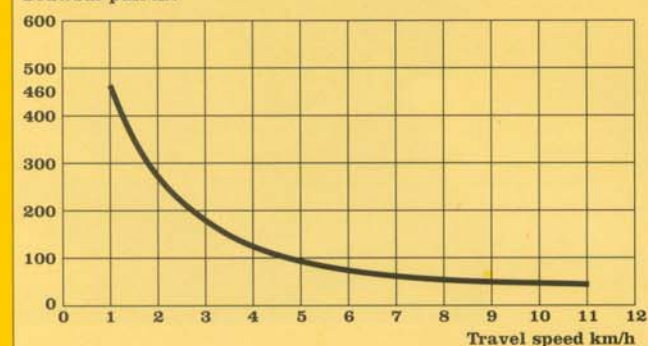

## Track Frame

Design	maintenance-free tractor-type track frames
Mount	elastic components at a separate pivot shaft
Chains	lubricated, track chain tension via grease tensioner, single grouser pads
Chain links	48
Sprockets	3 replaceable segments
Track rollers	8
Carrier rollers	2
Ground contact area	5.86 m <sup>2</sup> / 3.083 sq.in.
Ground pressure	0.89 kg/cm <sup>2</sup> / 12.66 PSI

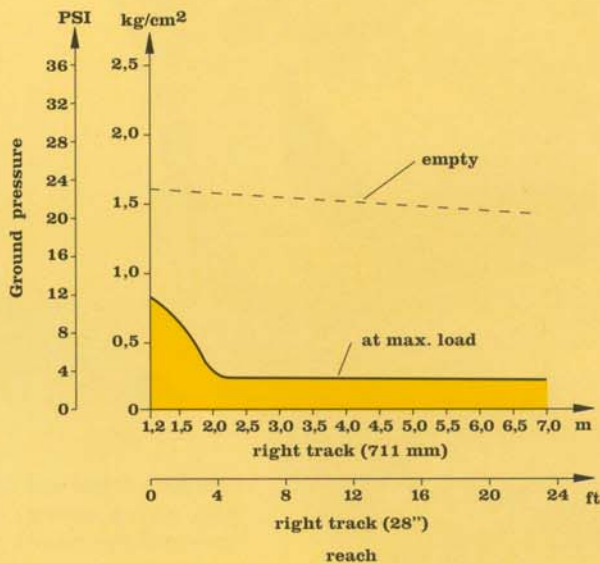
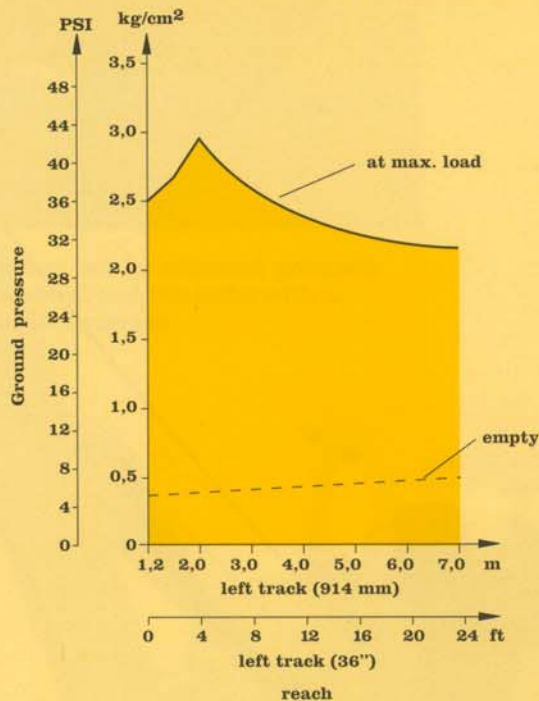





## Travel Control

- 1 Joystick lever \_\_\_\_\_ with electronic control for all travel functions: travel direction, speed, steering and counter-rotation
- Speed range 1 \_\_\_\_\_ 0 - 4 km/h / 0 - 2.5 mph
- Speed range 2 \_\_\_\_\_ 0 - 6.5 km/h / 0 - 4 mph
- Speed range 3 \_\_\_\_\_ 0 - 11 km/h / 0 - 6.8 mph
- Electronic engine speed sensing control \_\_\_\_\_ electronic regulation assures a constant balance between travel speed and necessary drawbar pull through engine speed sensing avoiding engine overload, even in partial load range
- Straight line travel \_\_\_\_\_ electronically controlled
- Parking/emergency brake \_\_\_\_\_ automatically applied after the joystick lever is put in neutral position
- Safety lever \_\_\_\_\_ inactivates complete travel and working hydraulic circuit and automatically activates parking brake
- Emergency shut off \_\_\_\_\_ push button on instrument panel immediately activates parking and emergency brake
- Inch-/Brake pedal \_\_\_\_\_ for reduction of travel speed to 0 km/h with integrated braking function



## Implement Hydraulic

- Hydraulic system \_\_\_\_\_ on demand (load sensing) control, swash plate type variable displacement pump and pressure cut-off for hoist winch and adj. boom and counterweight cylinder drive
- Max. pump flow \_\_\_\_\_ max. 292 l/min / 77.1 gal/min
- Pressure limitation \_\_\_\_\_ adjusted to 280 bar / 4060 PSI
- Control valve \_\_\_\_\_ 3 spool segments
- Filter system \_\_\_\_\_ return filter with magnetic rod in hydraulic tank
- Control \_\_\_\_\_ single servo-assisted joystick lever for hoist winch, counter weight and adjustable boom cylinder, safety lever prevents inadvertent movement, free fall device makes it possible to lower the load in case of danger, single joystick lever for counterweight



## Working Attachment

- Hoist winch \_\_\_\_\_ driven by variable flow hydraulic pump, control valve block and variable oil motor in open circuit. Brake valve helps to sensitively lower the load over total speed range, when the control lever is in neutral, a spring-loaded disk brake holds the load safely in any position
- Drum diameter \_\_\_\_\_ 305 mm / 12.01"
- Drum length \_\_\_\_\_ 254 mm / 10"
- Flange diameter \_\_\_\_\_ 566 mm / 1'10"
- Cable diameter \_\_\_\_\_ 20 mm / 0.79"
- Cable length \_\_\_\_\_ 65 m / 263'
- Hook block \_\_\_\_\_ 6 sheaves
- Hook speed in
  - 1. cable position \_\_\_\_\_ up 0 - 16,6 m/min. / 0 - 55 ft/min stepless
  - down 0 - 16,6 m/min. / 0 - 55 ft/min stepless
- Safety device \_\_\_\_\_ free fall control
- Adjustable boom control \_\_\_\_\_ through hydraulic cylinder, the lifting and lowering speed of the boom and the hook block can be changed steplessly, drives are fully independent and can be actuated at the same time. A check valve keeps the boom leakage free in any position and prevents uncontrolled boom drop in case of loss of pressure

### Adjustable boom cylinder

- Piston diameter \_\_\_\_\_ 210 mm / 8.27"
- Rod diameter \_\_\_\_\_ 110 mm / 4.33"
- Stroke \_\_\_\_\_ 1460 mm / 4'9"
- Boom \_\_\_\_\_
- Design \_\_\_\_\_

- Fixed boom \_\_\_\_\_ box-type welded structure made of highly resilient, grain refined steel
- length 7000 mm welded box sectioned
- Counterweight \_\_\_\_\_ installed on the right hand side of the machine, total weight extractable (12.193 kg / 26,999 lb) removable weight of 9,289 kg / 20,482 lb

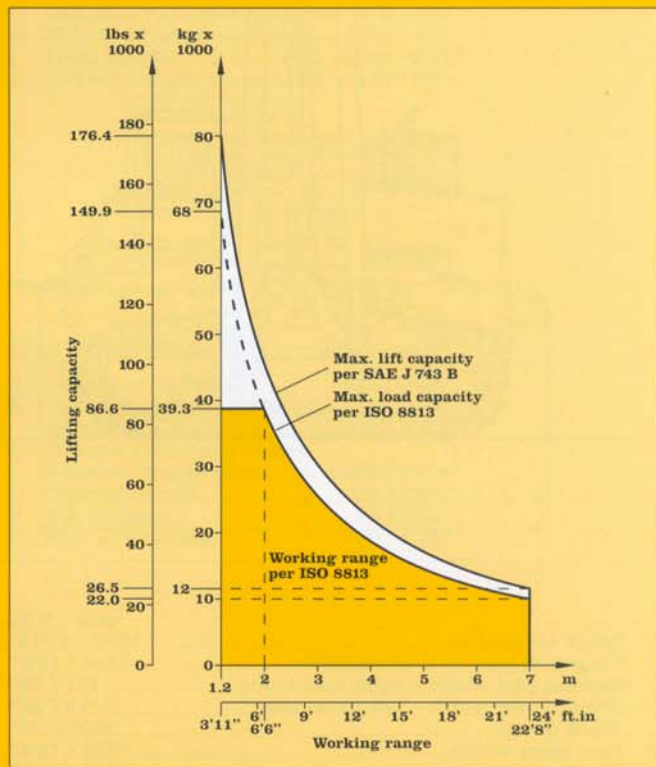

## Operator's Platform

- Mount \_\_\_\_\_ resiliently mounted
- Operator's seat \_\_\_\_\_ fully adjustable swing seat, adjustable to operator weight
- Rops-canopy \_\_\_\_\_ resiliently mounted, can be tilted with hand pump to 40° to the rear for accessibility to machine components
- Monitor \_\_\_\_\_ comprehensive instrument panel on the right hand side of the operator's seat



## Refill Capacities

- Fuel tank \_\_\_\_\_ 610 l / 161 gal
- Cooling system \_\_\_\_\_ 68 l / 18 gal
- Engine oil \_\_\_\_\_ 24 l / 6.3 gal
- Splitterbox \_\_\_\_\_ 6 l / 1.6 gal
- Hydraulic tank \_\_\_\_\_ 210 l / 55.4 gal
- Final drive, each \_\_\_\_\_ 21 l / 5.5 gal

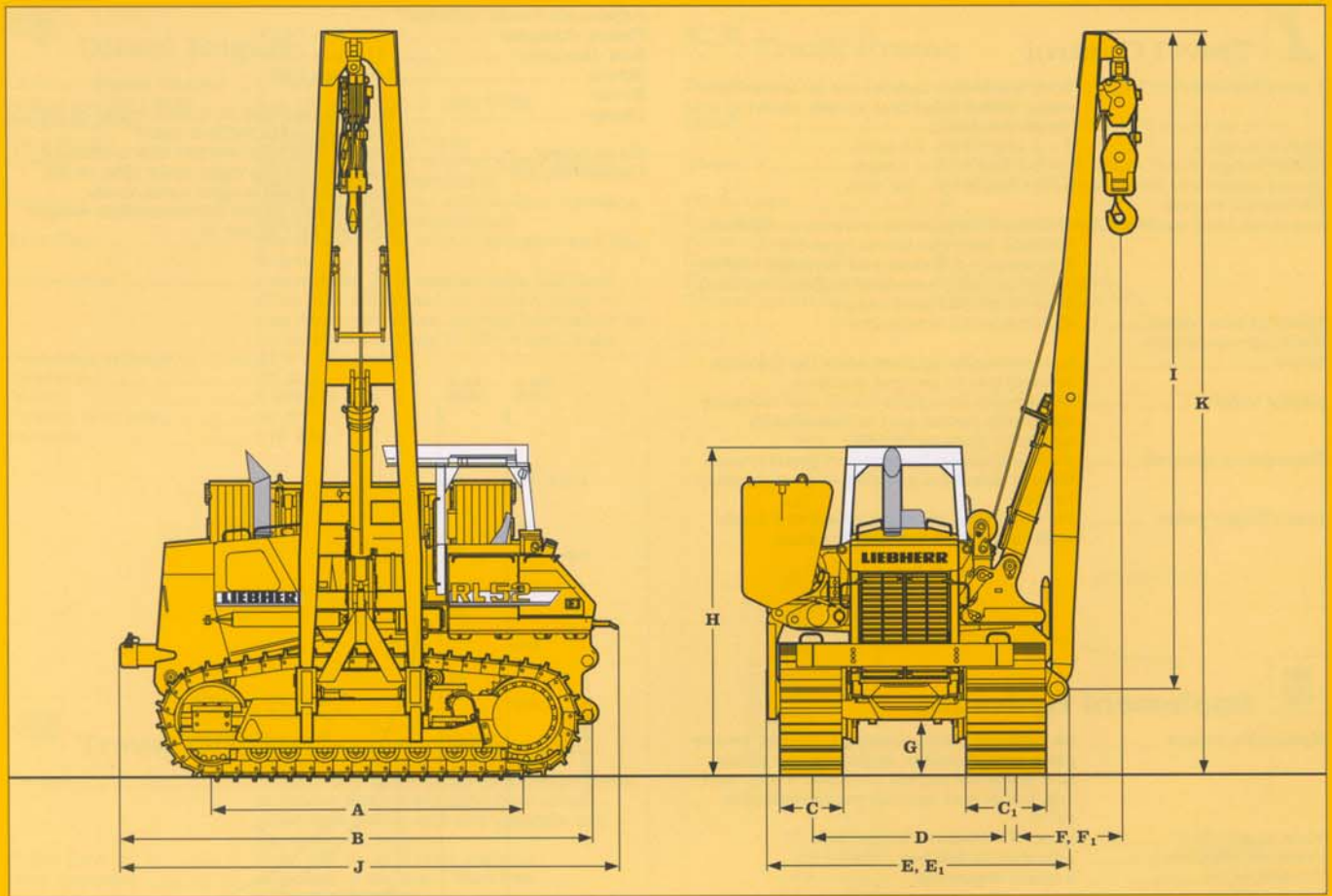

	mm / ft-in
A Track on ground	3605 / 11'10"
B Length to rear end of machine	5544 / 18'2"
C Ground pad width - right hand side	711 / 28"
C1 Ground pad width - left hand side	914 / 36"
D Track gauge	2260 / 7'5"
E Transport width	3755 / 12'4"
E1 Width counterweight extended	5509 / 18'1"
F Boom overhang, min.	1200 / 3'11"
F1 Boom overhang, max.	7002 / 23"
G Ground clearance	625 / 2'1"
H Transport height	3640 / 11'11"
I Boom length	7000 / 23"
J Total length	5776 / 18'11"
K Total height	8070 / 26'6"

### Basic Machine Contents:

- Pipe layer RL 52 with Liebherr Diesel engine D 9406 TI-E
- Chain D8N, single grouser track pads 914/711 mm / 36"/28", 48 links, sealed and lubricated
- Canopy
- Hoist winch
- Counter weight 12.193 kg / 26,886 lb
- Boom 7000 mm / 23"



## Winch

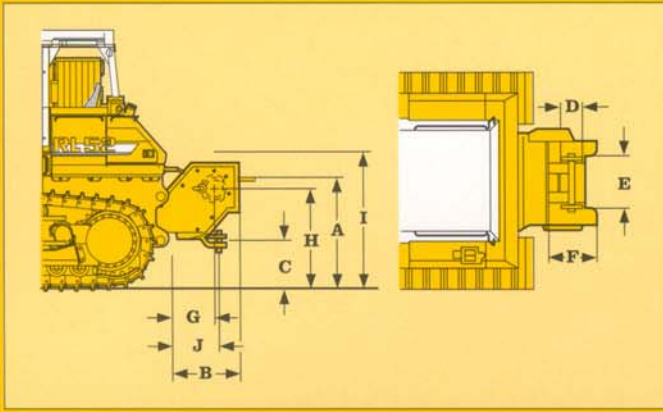

Max. line pull:	530 kN / 119,107 lbs
Max. line speed:	0-20 m/min. / 21.87 yards/min
Cable size:	28 mm / 1.1"
Cable length:	60 m / 65,62 yards
Weight:	2588 kg / 5.707 lbs

### Dimensions

	mm / ft-in
A Height, cable exit	1525 / 5'0"
B Overall length	1189 / 3'11"
C Height drawbar	801 / 2'8"
D Drum diameter	318 / 1'1"
E Coiling width	737 / 2'5"
F Flange diameter	610 / 2'0"
G Distance to center of drum	678 / 2'3"
H Height of drum center	1352 / 4'5"
I Total height	1801 / 5'11"
J Overall length of drawbar	919 / 3'0"

## Swinging drawbar

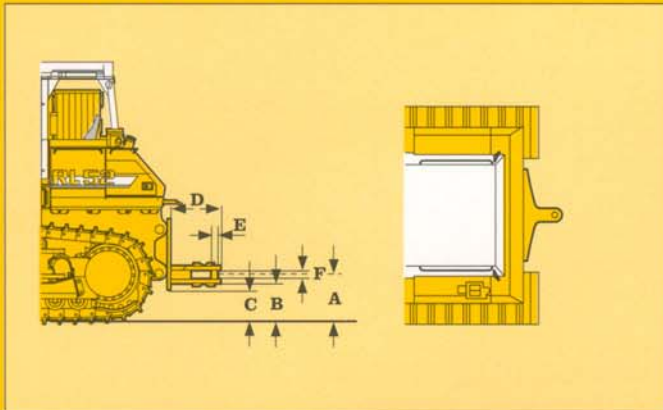

Weight:	662 kg / 1460 lbs
---------	-------------------

### Dimensions

	mm / ft-in
A Height of drawbar	615 / 2'0"
B Ground clearance below drawbar	513 / 1'8"
C Ground clearance below drawbar suspension	463 / 1'6"
D Overall length	460 / 1'6"
E Pin diameter	60 / 2.36"
F Size of opening	105 / 4.13"

## Basic machine

	Standard	Option
Towing hitch rear	●	
Towing lug front	●	
Battery compartment lockable	●	
Filling with oil SAE 10		●
Filling with oil SAE 30		●
Refuelling pump electrical		●
Belly pans heavy duty	●	
Cold start device ether		●
Cold start device glow plug	●	
Radiator coarse mesh	●	
Radiator guard 2-piece, hinged	●	
Liebherr Diesel engine	●	
Fan - hydraulically driven	●	
Fan guard		●
Engine oil cooler	●	
Engine doors perforated		●
Engine doors hinged, lockable	●	
Lugs for crane lifting	●	
Bumper front	●	
Special paint		●
Fuel water separator	●	
Fuel water separator with electric heater		●
Air filter dry-type, dual step	●	
Precleaner with automatic dust ejector	●	
Preheater for engine electric		●
Tool kit in batteries compartment	●	

## Travel drive

Parking brake automatic	●	
Function control automatic	●	
Control - single lever	●	
Load limit control electronic	●	
Travel control electronic	●	
Travel control 2-speed		
Travel control 3-speed	●	
Hydrostatic travel drive	●	
Emergency stop	●	
Oil cooler	●	
Final drives planetary gears	●	
Safety lever	●	

## Undercarriage

Track shoes extreme service (ESS)	●	
Track frame closed	●	
Sprocket segments bolt-on	●	
Master link 2 piece	●	
Track guide center part		●
Tracks oil lubricated	●	
Undercarriage standard	●	
Pivot shaft separate	●	

## Electric system

Starter motor 6,6 kW		
Starter motor 9 kW	●	
Working lights rear 2 units	●	
Working lights front 2 units	●	
Working lights side 2 units	●	
Battery main switch electric	●	
Batteries, heavy duty cold start	●	
On-board system 24 V	●	
Alternator 55 A		
Alternator 80 A	●	
Back-up alarm		●
Horn	●	

## Operator's cab

	Standard	Option
Operator's seat 6-way adjustable	●	
ROPS-canopy	●	
ROPS/FOPS-cab sound suppressed		●
Protective grid for canopy rear		●

## Instruments - Indicators

Battery charging	●	
Hour meter	●	
Electronic control	●	
Speed range	●	
Engine oil pressure	●	
Water temperature	●	
Oil pressure cooling circuit	●	
Oil level final drives	●	
Fuel level	●	
Contamination hydraulic filter	●	
Contamination air filter	●	
Cold start Diesel engine	●	

## Implement hydraulic

Control group boom	●	
Control group hoist winch	●	
Control group rear winch		●
Control group generator 75 kVA		●
Control group generator + pipe facing		●
Variable flow pump, load sensing	●	
Oil filter with strainer in hydraulic tank	●	
Hydraulic servo control	●	

## Attachments

Drawbar rear hinged		●
Drawbar rear rigid		●
Boom 2-piece foldable 4750 mm		
Boom single piece 4750 mm		
Boom single piece 6000 mm		●
Boom single piece 7000 mm		●
Boom single piece 7320 mm		
Boom jib		
Counter weight rear		●
Rear winch		●