

NORDBERG SW348

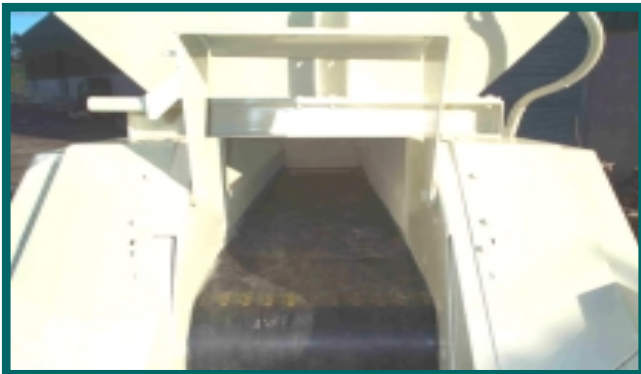

The SW348 features three onboard conveyors and is ideally suited for small to medium sized contractors and aggregate producers. It's high output 8' x 4' four bearing, double deck, positive action screen, large capacity hopper and hydraulically folding 600mm wide belts, ensure more tonnes per hour and consequently lower cost products.

The Nordberg SW348 grid, hopper and feeder:



- Grid length 1.8m (5' 10") and grid width 2.9m (9' 10"). Nominal spacing of 127mm (5").
- Grid bars made from high strength EN8 steel.
- Grid bars fixed at high end and loose at discharge end.
- Hydraulic tipping grid with remote control option.
- Hopper loading width 3.8m (12' 7") and height 3.4m (11' 2"). Hopper capacity 5.2m³ (6.8 cu yd).
- 750mm (30") wide feeder belt with optional variable speed.
- Feeder drive drum (diamond lagged) has chain and sprocket drive via high torque hydraulic motor.
- Large grid area and large spacing means quicker feed of material into hopper and faster cycle times.
- Longer life and less easily damaged than mild steel.
- Lodged stones will fall free when grid is tipped.
- One touch operation for clearing debris from grid.
- Additional width and hopper capacity suitable for large loading shovels. Small loading ramp needed only.
- Precise control of material for efficient screening.
- Feeder can start from stop with hopper full of material. Lagged drum prevents slippage.

Nordberg SW348 main and product conveyor:



- 750mm (30") wide main conveyor.
- Main conveyor angle of 24°
- Removable skirt plates along the entire length of main conveyor.
- Coupling drive via high torque hydraulic motor. Diamond lagged drive drum.
- 750mm (30") wide product conveyor.
- Hydraulic folding product conveyor. One lever operation.
- Product conveyor angle of 24°
- 3.8m (12' 7") height, 106m³ (138 cu yd) capacity under conveyor.
- Feed material spread evenly over the width of conveyor
- Prevents roll back of material.
- Allows easy access to rollers for maintenance = less down time.
- Main conveyor can start from stop under full load. No slippage during use.
- Wide belt for high production.
- Quick set up times and fold away times.
- Prevents roll back of material.
- More time feeding machine, less time taking product away = more production.

Nordberg SW348 screen and wing conveyors:



- 2.4m x 1.2m (8' x 4'), four bearing, double deck, positive action screen box.
- End to end tensioned meshes.
- Screen eccentric is 6.4mm (.25").
- Adjustable, free floating spreader plate, spreads material over complete width of screen.
- Walkway at rear of screen, accessible via fixed ladders at both sides of screen.
- 600mm (24") wing conveyor, 4.3m (14' 3") height, stockpile capacity 150m³ (196 cu yd).
- Patented folding action.
- Variable speed on top deck oversize conveyor.
- Screen does not slow down with material on screen = more efficient screening, higher production.
- Best camber for efficient screening.
- High production screening in difficult material.
- Complete width of screen is used, which leads to higher production and efficient screening.
- Ease of access when changing meshes. No set up required.
- More time feeding machine, less time taking product away = more production.
- Allows for legal transport width.
- Prevents roll back of rounded stones.

Nordberg SW348 engine and axle:



- Deutz F4L1011, 50HP / 37kW @ 2315 rpm.
- All controls at centralised location within easy reach.
- All set up and tear down operations are hydraulically controlled.
- Lockable security engine enclosure.
- Easy access to hydraulic filters for servicing.
- Danfoss and Lamborghini hydraulic components used.
- 412 Lt (109 gallon) capacity hydraulic tank.
- Dual Granning air braked and sprung axles with dual wheels. On site towbar.
- Reliable engine manufacturer, with engine running below capacity giving it a long life.
- Fast setup and ease of use for operator.
- Quick set up and fold away without need for auxiliary equipment.
- Vandal resistant.
- Service downtime is kept to a minimum.
- Long life, low maintenance and reliable.
- Acts as cooling reservoir for oil capacity to drive other components.
- Compliant with most country transport regulations. Ease of transport on and off site.

Nordberg SW348 options:

Shredder:



- 16 no. Manganese tips used to break up material.
- Heavy duty chain curtain inside shredder chamber.
- Hydraulically folds out of position when not in use.
- Peat blades (knives) can be purchased as option to replace manganese tips.
- Sealed for life bearings and Danfoss hydraulic motor.
- Can be used in very abrasive material, long lasting.
- Helps meter material flow onto shredder tips.
- Quick change over time from when shredder is not in use.
- No need to purchase additional shredder unit for light material.
- Low maintenance costs.

SCOPE OF SUPPLY

Feature	Machine Specification		
	Base	Euro 1	Euro 2
Grid and Feeder			
Manual tipping grid	Opt.	Opt.	Opt.
Hydraulic tipping grid	Opt.	Opt.	Opt.
Remote hydraulic tipping grid	Opt.	Opt.	Opt.
Variable speed feeder	Opt.	Opt.	Opt.
Screen			
Two deck, four bearing screen	Incl.	Incl.	Incl.
Platform on rear of screen	Incl.	Incl.	Incl.
Access ladders to both sides of platform	Incl.	Incl.	Incl.
Remote greasing of screen bearings	Incl.	Incl.	Incl.
Main / Wing / Product Conveyors			
Hydraulic folding	Incl.	Incl.	Incl.
Skirt plates / side guards length of main conveyor	Incl.	Incl.	Incl.
Engine and Hydraulics			
F4L1011 Deutz engine	Incl.	Incl.	Incl.
Lamborghini tandem hydraulic pump	Incl.	Incl.	Incl.
Hydraulic jacklegs	Incl.	Incl.	Incl.
Engine canopy enclosure	Incl.	Incl.	Incl.
Emergency stop kit	Incl.	Incl.	Incl.
Hydraulic oil cooler	Incl.	Incl.	Incl.
Axle and Transport			
Braked axles with auto slack adjusters	Incl.	N/A	N/A
Braked axles with manual slack adjusters	N/A	Incl.	Incl.
12V ABS unit	Opt	N/A	N/A
24V ABS unit	N/A	Incl.	Opt.
12V Light system	Incl.	N/A	N/A
24V Light system (CE approved)	N/A	Incl.	Incl.
Other Options			
Shredder	Opt	Opt	Opt

Nordberg SW348 Sales Presentation

	<u>UNITS</u>			<u>SW348</u>	
	English	Conv. (x)	Metric	English	Metric
Hopper:					
Hopper capacity	yd ³	0.7646	m ³	6.8	5.2
Hopper loading width	ft	0.3048	mm	12' 7"	3.8
Hopper loading height (min)	ft	0.3048	mm	11' 2"	3.4
Grizzly area	ft	0.3048	mm	9' 10"x5' 10"	2.9x1.8
Grizzly spacing	in	25.40	mm	5"	127
Grizzly angle	°	1.0000	°	20°	
Conveyor(s):					
Feed conveyor width	in	0.0254	mm	30	750
Feed conveyor speed	ft/min	0.3048	m/min	45	13
Main conveyor width	in	0.0254	mm	30	750
Main conveyor height (ctr)	ft	0.3048	mm	13' 11"	4.24
Main conveyor angle	°	to	°	24°	
Main conveyor speed	ft/min	0.3048	m/min	306	93
Product conveyor width	in	0.0254	mm	30	750
Product conveyor height (ctr)	ft	0.3048	mm	12' 7"	3.8
Product conveyor angle	°	1.0000	°	24°	
Product conveyor speed	ft/min	0.3048	m/min	345	105
Wing conveyor width	in	0.0254	mm	24	600
Wing conveyor height (ctr) @25o	ft	0.3048	mm	14' 3"	4.34
Wing conveyor angle	°	1.0000	°	20° and 25°	
Wing conveyor #1 speed (var)	ft/min	0.3048	m/min	156	47
Wing conveyor #2 speed (fixed)	ft/min	0.3048	m/min	180	54



Nordberg SW348 Sales Presentation

	<u>UNITS</u>			<u>SW348</u>	
	English	Conv. (x)	Metric	English	Metric
Screen Box / Shakerhead:					
Screen box type				4 BRG	
# Decks				2	
Screen angle	°	to	°	30°	
Screen speed	rpm	to	rpm	1175 +/- 25	
Screen eccentric (circle size)	in	25.40	mm	0.25	6.4
Screen box size (nominal)	ft	0.3048	mm	8' x 4'	2.4 x 1.2
Screen area	ft ²	0.0929	m ²	32	2.88
Impact Shredder-Hammermill speed		rpm		629	
Engine: (Motor)					
Standard Manufacturer / Model				Deutz, F4L1011	
Type / # cylinders				Air Cooled, 4 cyl, diesel	
Max. Highly Intermittent power		hp @ rpm		56 hp @ 2800 rpm	
Max. Highly Intermittent power		kW @ rpm		42 kW @ 2800 rpm	
Power @ operating RPM		hp @ rpm		50 hp @ 2315 rpm	
Power @ operating RPM		kW @ rpm		37 kW @ 2315 rpm	
Operational speed		rpm		2315	
Operational Specifications:					
Overall length (working)	ft	0.3048	mm	50' 6"	15.39
Overall height (working)	ft	0.3048	mm	14' 3"	4.34
Overall width (working)	ft	0.3048	mm	43' 6"	13.25
Fuel tank capacity	gal	3.7850	L	37	140
Hydraulic tank capacity	gal	3.7850	L	109	412
Transport Specifications:					
Towing arrangement				5th Wheel	
Brakes				Air	



	UNITS			SW348	
	English	Conv. (x)	Metric	English	Metric
# Axles				2	
Overall width (Transport Mode)	ft	0.3048	mm	8' 2"	2.49
Overall height (Transport Mode)	ft	0.3048	mm	13' 0"	3.97
Overall length (Transport Mode)	ft	0.3048	mm	42' 6"	12.95
Length axle (ctr) to end (Transport)	ft	0.3048	mm	10' 2"	3.09
Length 5th wheel to end (Transport Mode)	ft	0.3048	mm	40' 3"	12.26
Overall weight	lb	0.4536	kg	30,473	13,820
Tongue weight	lb	0.4536	kg	8,114	3,680
Axle weight	lb	0.4536	kg	22,359	10,140
Relief valve settings:					
Stage 1 valve bank	PSI	0.0689	bar	3190	220
Stage 2 valve bank	PSI	0.0689	bar	3190	220

Due to the Metso Minerals policies of continued product improvements, specifications are subject to change without notice or obligation. No representation is made that the products depicted herein comply with any laws, codes, rules, regulations or standards. Compliance is the responsibility of the user. Additional safety equipment may be required by the particular location and application of product.

Nordberg SW348 Side View in Working Position:

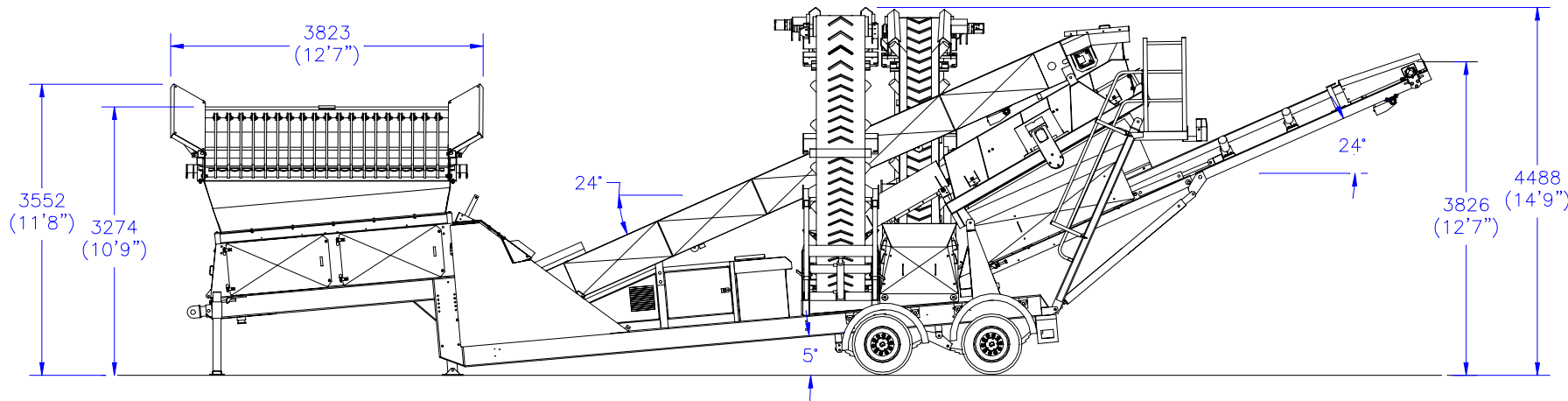

Nordberg SW348 End View in Working Position:

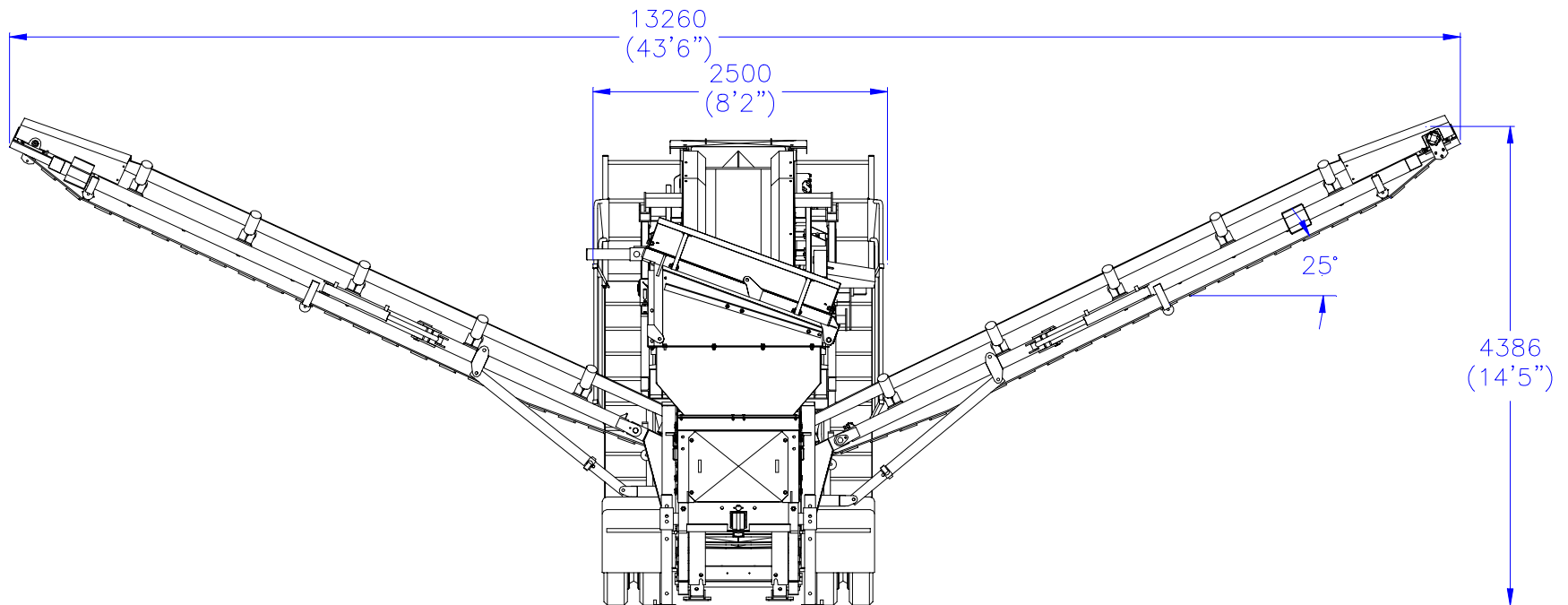

Nordberg SW348 Side View in Transport Position:

