

Information on service and
dealer network:



KAMAZ Foreign Trade
Company Incorporated
business card:



For additional information please visit the website www.kamaz.ru/en

KAMAZ Foreign Trade Company Incorporated - subsidiary of KAMAZ PTC engaged in the export
of KAMAZ PTC products and sales and service development abroad

The manufacturer reserves the right to change specifications without any notice.
This edition is an advertisement and may not be considered as a normative document

KAMAZ PTC
2018

KAMAZ-65117 6x4 (T2030, T2426-T2430) chassis

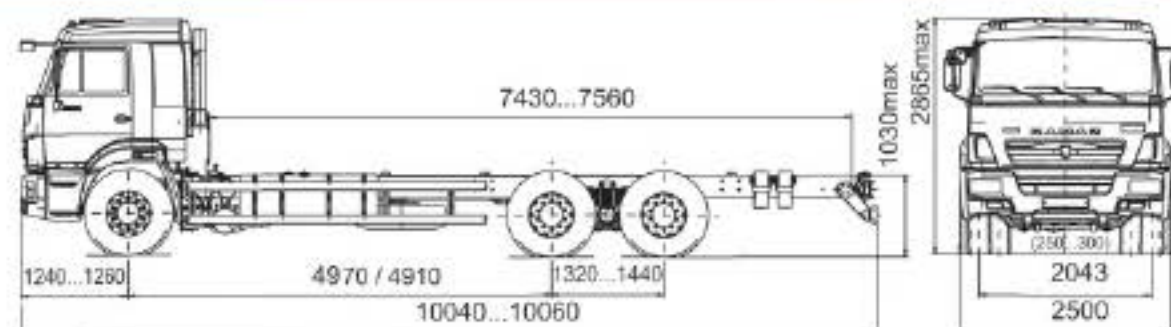

Dimensions with curb (gross) weight
4910+1440 mm wheelbase is used in modifications with the rear air suspension

Application

Logistics



- Drop-side truck
Payload
11.6-14.6 tn
[n.92-93](#)

Lift vehicles

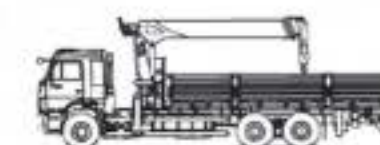

- Drop-side truck
with loader crane
Payload
10-11.7 tn
[o.86](#)

● KAMAZ products

Power unit

Engine	Make	Engine power / Component model		
		260	280	300
Diesel	Euro-2, EC-3	KAMAZ	740.30-260	
	EC-3	Cummins		6ISB α 300
	Euro-3	KAMAZ		740.62-280
	EC-4	Cummins		ISB6.7 300
	Euro-4	Cummins		ISB6.7 α 4 300
	Euro-5	Cummins		ISB6.7E5 300
Gas	Euro-4	KAMAZ		820.62-300
	Euro-5	KAMAZ		820.92-300 / 740.705-300
Clutch	ZF Sachs	MFZ-430		
Gearbox	KAMAZ	154		154 ¹
	ZF			9S1310TO

Cab

Day Cab (no sleepers)	Sleeper Cab (1 sleeper)	High Sleeper cab (2 sleepers)
	C3	
	R	
	C3 / R	
	R	
	R	
	R	
	R	
	R	

¹ only with 820.62-300 and ISB6.7 300 engines

Technical specifications

Weights and loads / engine type	Diesel	Gas (CNG)	Gas (LNG)
Chassis curb weight, kg	7925...8425	8600	8200
- front axle, kg	3775...4275	4250	4050
- rear tandem axle, kg	4150	4350	4150
Gross vehicle weight, kg	20000² / 24000	24000	
- front axle, kg	4400 ² / 6000	6000	
- rear tandem axle, kg	15600 ² / 18000	18000	
Chassis payload, kg	9500...12000 ² / 15500...16000	15400	15800
Trailer permissible weight, kg		14000	
Gross combined weight rating, kg	34000² / 38000	38000	
Final drive			
Gear ratio	4.98 or 5.43 or 5.94		
Type	Central double		
Feed system			
Fuel tank capacity, l	500	800 (4x100+4x100)	500 (effective volume 450)

Technical specifications

Wheels and tyres	
Wheel size	7.5-20 or 7.50x22.5
Tyre size (*tubeless)	11.00R20 or 11R22.5*
Specifications for a fully-loaded vehicle	
Max. speed, km/h	100
Gradeability, single / combination vehicle, % (degrees)	25% (14°) / 18% (10°)
Wall-to-wall turning circle, m	11.5
Front suspension	
Dependent, leaf spring / air, with hydraulic telescopic shock absorbers and stabiliser bar (excluding chassis with 3690+1320 mm wheelbase)	
Rear suspension	
Dependent, leaf spring, equalizing beam, with torque rods / (for chassis with 4910+1440 mm wheelbase: dependent, air with hydraulic shock absorbers and torque rods)	
Primary brake system	
Pneumatic dual circuit braking, ABS, ASR, drum brakes on all wheels	
Parking brake system	
Rear tandem axle wheel brake gears actuated by the spring accumulator drive	
Emergency brake-system	
Every circuit of the primary brake system	
Auxiliary brake-system	
Damper plate in the exhaust system	

¹ for 3690 + 1320 mm wheelbase

Drop-side trucks and (semi-) trailer trucks



2-axle drop-side vehicle



3-axle drop-side vehicle

Vehicle type	Layout view	Wheel arrangement	Payload, kg	Platform's internal length, m	Platform volume, without / with canvas	Chassis models	Combination vehicle maximum gross vehicle weight, kg
● 2-axle drop-side truck		4x2	5150-7500	5162 - 6112 7258 5162	9-11 / 34-40 13 / 48 9 / 23	4308 5308 43253 5325 43265	19900 28000 - - -
		4x4	8850-9525	5162-7000	tbd	43265	-
● 2-axle offroad drop-side truck		4x4.1	4150-4450	4892	9 / 22	43502 / 4326	19700
● 3-axle drop-side truck		6x4	11500-14500	6112	11 / 36	53215	33650
				7798	14 / 47	65117	38000
		7428		13 / 31	6520	53100	
		7800		14 / 47	65208	44000	
7800	14 / 47	65207	44000				
● 3-axle offroad drop-side truck		6x6.1	7320-11220	4892 - 5432 5162	9 - 10 / 18-20 9 / 19	5350 / 43114 43118	33600
		8x8.1	14000-20120	6648	12 / 26	63501	37750
7258	13 / 33			6560	-		

● KAMAZ products

Drop-side (semi-) trailer trucks



KAMAZ-65207 grain carrier



Combination vehicle: KAMAZ-5490 tractor unit with a drop-side semi-trailer



Combination vehicle: KAMAZ-65116 tractor unit with drop-side semi-trailer

Trailer, semi-trailer type	Layout view	Wheels per semiaxle	Trailer / semi-trailer		Combination vehicle			
			Payload, kg	Body volume, m ³	Chassis and tractor units variants	Payload, kg	Cumulative volume, m ³	
• 2-axle drop-side trailer		2	11300 - 16650	11-43	65117 (6x4) 65207 (6x4)	p.36 p.51	22600-31250 25800/311150	22; 25; 78.89 86.4/ 93.16
• 2-axle drop-side trailer		1	7400-14800	11-43	5308 (4x2) 65117 (6x4) 65207 (6x4) 43118 (6x6.1) 63501 (8x8.1)	p.29 p.36 p.51 p.40 p.47	13300 18730-22400 25225 19425 22525	14; 49.3-53 22-92 25.2-93.16 22.08; 65.7 22.98; 66.2
• 3-axle drop-side trailer		2	14700-16500	14.5-47.5	65117 (6x4) 43118 (6x6.1)	p.36 p.40	up to 40000	up to 100
• 3-axle drop-side trailer		1	14900-16650	14.5-47.5	65117 (6x4) 43118 (6x6.1)	p.36 p.40	up to 37600	up to 100
• 2-axle drop-side semi-trailer		2	16500-29000	18 - 78.0	5460 (4x2) 65116 (6x4) 65206 (6x4) 65209 (6x4) 6460 (6x4) 54115 (6x4)	p.55 p.57 p.66 p.65 p.58 p.58	21900 15600-20000 18600 18600 27900-28500 15600-20000	18-60 18-60 59 59 22-78 18-60
• 2-axle drop-side semi-trailer		1	17000 - 22500	19.2 - 50.0	53504/ 44108 (6x6.1)	p.59	17900-22500	18-50
• 3-axle drop-side semi-trailer		1	26190 - 33400	24.0 - 91.0	6460 (6x4) 5490 (4x2) 65806 (6x4)	p.58 p.64 p.67	21500-32000 25900 21500-32000	24-91 24-91 24-91

• KAMAZ products

+7-8552-45-27-45 | www.kamaz.ru