

300 Flywheel Horsepower

14/20 Cu. Yd. Capacity

CATERPILLAR

VPH
621
Wheel Tractor-
Scraper

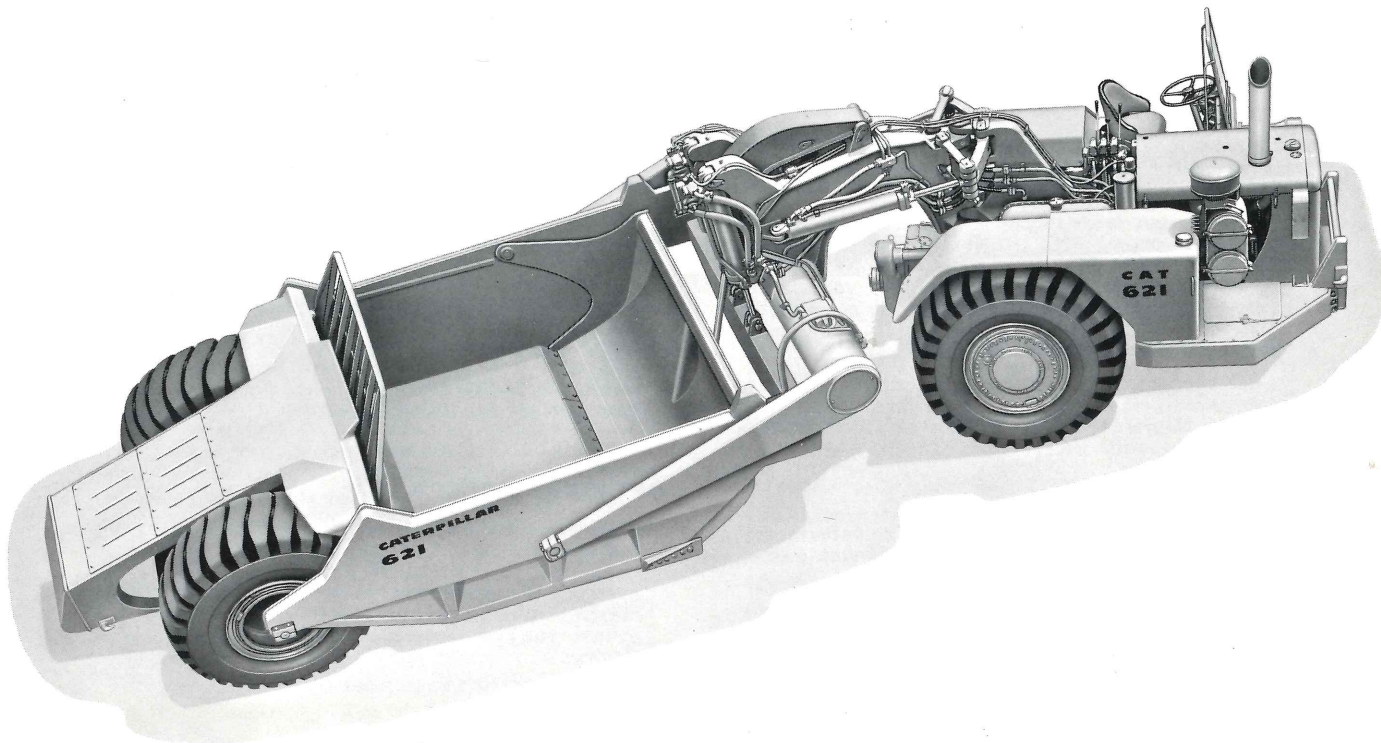

Positive-Action Scraper is hydraulically controlled for positive cutting edge penetration, apron closure and material ejection.

Extra-wide Bowl allows fast, easy loading to 20 heaped cu. yd. (15,3 m³). Struck capacity is 14 cu. yd. (10,7 m³).

Caterpillar Diesel Engine provides 300 flywheel HP and features automatic fuel-injection timing advance for optimum performance at all RPM.

Power Shift Transmission has eight manually selected forward speed ranges with top speed of 30 MPH (48,3 km/h). Optional semi-automatic range selector also available.

Servicing Ease is assured with all major components accessible and independently removable.

621 TRACTOR

CATERPILLAR ENGINE:

Flywheel Horsepower @ 2200 RPM 300

Flywheel horsepower is the net horsepower at flywheel of standard engine operating under normal temperature and barometric conditions [up to 10,000 ft. (3000 m) altitude]. Standard engine equipment includes fan, air cleaners, water pump, lubricating oil pump, fuel pump, charging generator and air compressor.

NACC H.P. for U.S.A. tax purposes 64.8

Design Data:

Four-cycle, 4.5" (114 mm) bore and 5.5" (140 mm) stroke, 60° V-type eight-cylinder diesel model D336. 700 cu. in. (11.5 lit.) displacement.

Turbocharger with intake air aftercooler. Parallel manifold porting with two intake and two exhaust valves per cylinder. Valves actuated by overhead camshafts acting through a roller rocker arm valve train. Variable Timing fuel system. Adjustment-free fuel pumps, non-clogging injection valves and precombustion chamber design.

Uses economical No. 2 Fuel Oil (ASTM Specification D396), often called No. 2 furnace or burner oil, with a minimum cetane rating of 35. Expensive, premium-quality diesel fuel can be used, but is not required.

Starting Methods, choice of:

Direct Electric Diesel Starting (24-volt motor).
Gasoline Engine Diesel Starting (12-volt gas engine starter).

POWER SHIFT TRANSMISSION:

Caterpillar-built for 621. Eight manually selected speed ranges with single-lever shift control. First and second are torque converter drive for high torque anti-stall characteristics. Remaining six ranges are direct drive for maximum efficiency on the haul.

Optional semi-automatic speed selector provides automatic shifting in ranges 3 through 8. A foot operated hold control, when engaged, prevents any shifting up or down. Reverse, 1st and 2nd are manually selected. Upshifting is limited to the speed selected by the control lever.

DIFFERENTIAL CONTROL:

Caterpillar-built Differential Lock, engaged by foot pedal, positively prevents either drive wheel from spinning free in poor traction conditions. Allows normal differential action when not engaged.

FINAL DRIVE:

Compact planetary design and full floating axles, removable independently of wheel mounting. Service-free, double-row roller bearings. Assemblies protected with Duo-Cone Floating Ring Seals.

TIRES (Tubeless):

Standard for tractor and scraper 26.5 x 29 (24 PR)
Wider optional tires..... 29.5 x 29 (22 PR)
29.5 x 29 (28 PR)

Additional tire options can be provided for special applications.

STEERING:

Two double-acting hydraulic cylinders with follow-up linkage.

Cylinders bore and stroke 5" x 32"
(127 mm x 810 mm)

Width required for non-stop turn 36' 5" (11100 mm)

BRAKES:

Air-actuated, cam-operated, expanding-shoe type (synchronized to brake scraper first). Drive wheels may be braked individually by hand lever. (Optional: hydraulic retarder).

STANDARD EQUIPMENT:

Bucket-type torsionflex seat, nylon seat belt, safety glass windshield, air vent, heat vent, dash lights, air horn, dry-type air cleaner and headlights. Maintenance tools and tool box. Charging generator and two 200-ampere hour, 12-volt batteries for 24-volt system (One 12-volt, 65-ampere hour battery for 12-volt system).

OPTIONAL EQUIPMENT:

Rear-mounted flood lights. Cap locks for fuel tank, radiator, oil filler and hydraulic tank. Instrument panel guard. Alternator for 12-volt and 24-volt systems. Engine hood door r.h., rain cap, ether starting aid, tool kit (open end wrenches and grease gun) and windshield wiper. Parking brake, Hydraulic retarder, Quick-drop bowl control valve. Semi-automatic range selector.

WEIGHTS ON WHEELS

(Total Unit, Approx.)

| Empty: | LB. | (kg) |
|---------------|--------|---------|
| Tractor — 69% | 35,900 | (16300) |
| Scraper — 31% | 16,100 | (7300) |
| Total | 52,000 | (23600) |

Loaded, based on 48,000 lb.
(21800 kg) average load:

| | | |
|---------------|---------|---------|
| Tractor — 52% | 52,000 | (23600) |
| Scraper — 48% | 48,000 | (21800) |
| Total | 100,000 | (45400) |

SERVICE INFORMATION

| | U.S. GAL. | (lit) |
|-------------------------|-----------|-------|
| Fuel tank | 120 | (455) |
| Lubricating system: | | |
| Crankcase | 8¾ | (33) |
| Transmission | 20 | (75) |
| Differential | 18 | (68) |
| Final drive — each side | 3½ | (13) |
| Cooling system | 23 | (87) |
| Total hydraulic system | | |
| (Steering and scraper) | 36 | (136) |

621 POSITIVE-ACTION SCRAPER

CAPACITIES

Heaped, SAE rating 20 cu. yd. (15,3 m³)
 Struck, SAE rating 14 cu. yd. (10,7 m³)

SCRAPER DESIGN:

Low and extra-wide scraper bowl is operated by high-speed hydraulics. Cutting edge near center of bowl for minimum material travel. Power closing, "true radius" apron. Hydraulic, dozer-type ejector. Reinforced box-section construction with extensive use of high tensile strength steel. Straddle mounted wheels.

OPERATING DATA:

Maximum depth of cut 13" (330 mm)
 Width of cut (outside router bits) 9' 11" (3000 mm)

Cutting Edge Dimensions:
STANDARD Center Section . . . 7/8" x 16" x 56 1/4"
 (22 mm x 405 mm x 1430 mm)
 Each End Section 3/4" x 13" x 29 1/2"
 (19 mm x 330 mm x 750 mm)

OPTIONAL Center Section . . . 1 1/8" x 16" x 56 1/4"
 (29 mm x 405 mm x 1430 mm)
 Each End Section . . . 1" x 13" x 29 1/2"
 (25 mm x 330 mm x 750 mm)

Maximum available hydraulic penetration force
 @ cutting edge (approx.) . . . 28,400 lb. (12900 kg)
 Maximum depth of spread 17" (430 mm)
 Apron Opening — bowl 6" (150 mm)
 off ground level 5' 8" (1730 mm)
 Apron Closure Force with cutting edge
 fully raised and apron opened 12"
 (300 mm) approx. 24,000 lb. (10900 kg)

HYDRAULIC OPERATION:

Bowl, apron and ejector individually controlled. (Combination bowl-apron lever available.) Bowl lever has raise, hold and power down positions. Quick-drop bowl control valve available for maximum pump loading ability. Apron lever has open, hold, positive close and "float" positions. Ejector lever has forward, hold, and return positions. Automatic kickout on return.

Bowl uses two, 6.0" (152 mm) bore x 32.0" (810 mm) stroke, double-acting cylinders. Carry check valves isolate circuit from load in "hold" position.

Apron uses one 7.25" (184 mm) bore and 23.50" (600 mm) stroke, double-acting cylinder with multiplier linkage controlling force, speed and length of travel. Closure force regulated by relief valve protecting apron and bowl. Circuit pressure is controlled by sequence relief valve when bowl is raised with apron closed.

Ejector uses one 6.50" (165 mm) bore and 61" (1550 mm) stroke, double-acting cylinder.

Hydraulic Circuits are filtered, closed systems and powered by vane type pump:

Output @ 2000 RPM 79 GPM (299 lit/min)
 Relief valve setting 2000 PSI (141 kg/cm²)

OVERALL DIMENSIONS:

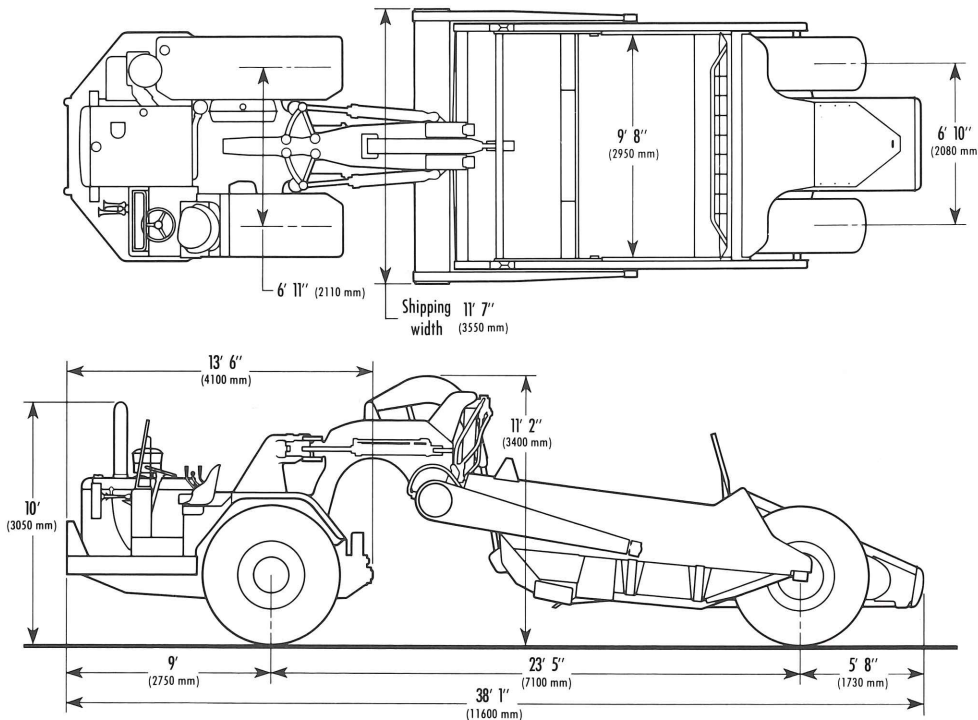

621

Wheel Tractor-Scraper

GRADEABILITY-SPEED-RIMPULL

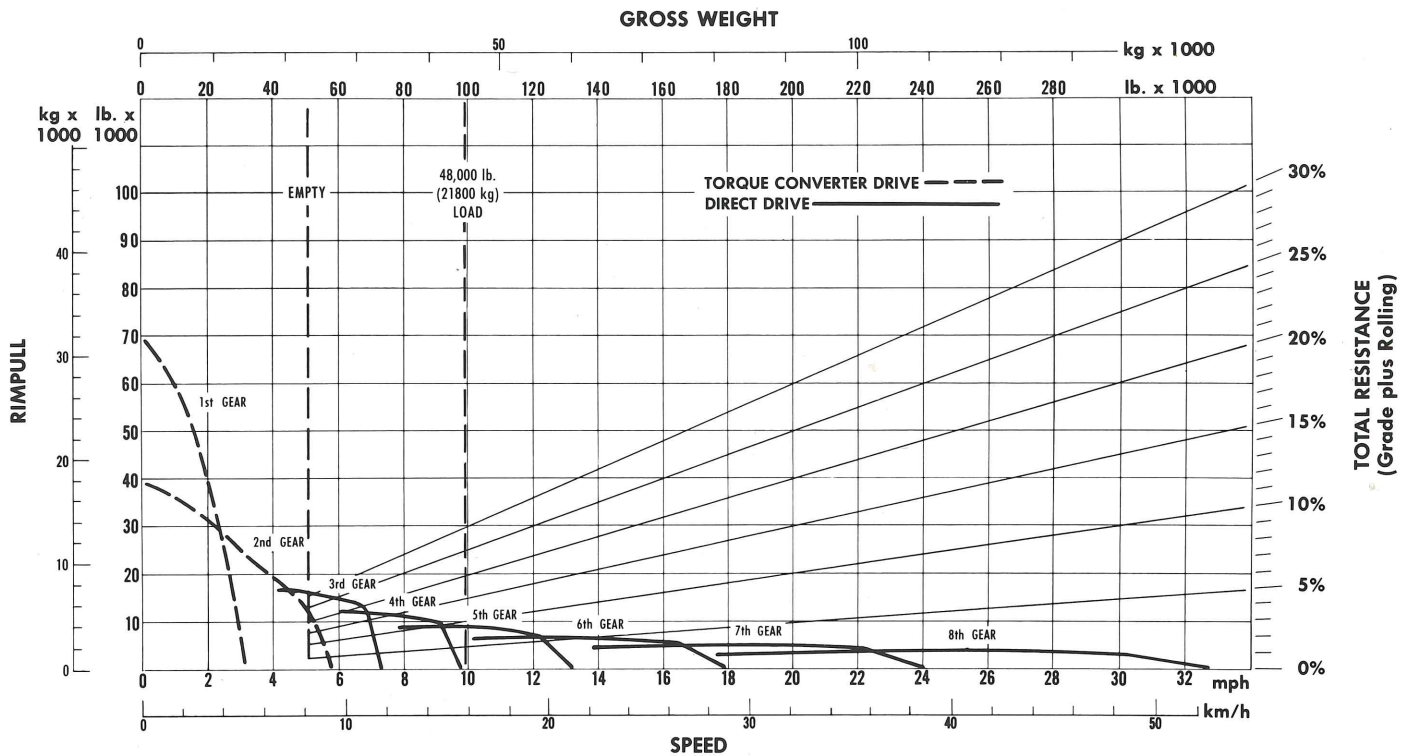

To determine gradeability performance: Read from gross weight down to the % of total resistance. [Total resistance equals actual % grade plus 1% for each 20 lb./ton (10 kg/t) of rolling resistance]. From this weight-resistance point, read horizontally to the curve with the highest obtainable speed range, then down to maximum speed. Usable rimpull depends upon traction available and weight on drive wheels.

Materials and specifications are subject to change without notice.

CATERPILLAR

Caterpillar and Cat are Registered Trademarks of Caterpillar Tractor Co.