

CB-534D
CB-534D XW
CB-564D
Vibratory Asphalt
Compactors



Cat® 3054C Turbocharged Diesel Engine

Gross Power 97 kW 130 hp

Drum Width

CB-534D 1.7 m 67"

CB-534D XW 2.0 m 79"

CB-564D 2.13 m 84"

Operating Weight (with ROPS)

CB-534D 10 380 kg 22,836 lb

CB-534D XW 11 300 kg 24,860 lb

CB-564D 12 600 kg 27,783 lb

Productivity and Reliability in a Durable Package

The CB-500 D-Series Asphalt Compactors offer compaction performance, application versatility and operator comfort in order to maximize productivity while providing exceptional product quality.

Vibratory Systems

Pod-style eccentric weights with more amplitude selections provide peak compaction performance and minimal service. The high dynamic force helps achieve density in the fewest number of passes.

The Versa Vibe™ vibratory system provides both high amplitude or high frequency in one machine for working on tough superpave mixes or on tender marshall mixes.

The dual amplitude/dual frequency vibratory system provides the capability of working in high frequency on thin lift applications.

Page 4

CB-564D

The CB-564D includes a 2.13 m (84") drum for increased lane coverage. It is a versatile machine that provides Versa Vibe as the standard vibratory system. The compactor can be used in breakdown or intermediate positions. When in the static mode, the CB-564D can be used in the finish position.

Page 5

Engine

Cat® 3054C turbocharged diesel engine delivers 97 kW (130 hp) and is built for performance and reliability without sacrificing fuel economy.

The cooling system delivers fresh air from above the engine for clean and efficient operation.

Page 5

Performance and Reliability You Can Depend On.

Based upon the industry-proven reputation of the Caterpillar® Asphalt Compactors, the CB-500 D-Series Asphalt Compactors establish innovative new standards for productivity and reliability in the asphalt compaction industry.

Durable Cat® powertrain, field-proven hydraulic systems, vibratory systems, and the world's largest and most dedicated dealer support system ensure the CB-500 D-Series Asphalt Compactors will provide maximum productivity.



Operator's Station

The operator's station features comfort and visibility. A tilting steering column, propel lever wrist rest, and conveniently located and grouped control switches and gauges enhance operator productivity and reduce fatigue.

Heavy-duty isolation mounts provide a smooth ride. Machines with the ROPS/FOPS platform include quick release handrails that can be individually adjusted to accommodate multiple operating positions. For FOPS protection to be effective, the operator must be seated under the canopy.

Page 6

Water Spray System

Caterpillar's exclusive dual-pump water spray system provides the operator with an efficient, easy access drum watering system. A large polyethylene tank, triple water filtration and infinitely variable spray settings are some of the benefits integrated into the system.

An optional overnight freeze protection kit is also available for cold weather construction.

Page 7

Serviceability

The one-piece fiberglass hood opens upward and rearward to allow access to the engine and daily maintenance points. Daily check points are accessible from ground level. Ground level service is also provided on the water spray system with pumps, filters, and drain valves grouped together and centrally located.

The rear mounted cooling system with fresh air intake reduces the need for cleaning. The engine oil change interval is 500 hours and the vibratory bearing lube service interval of 3 year/3000 hour keeps maintenance to a minimum and maximizes production. The articulation hitch area features sealed-for-life bearings that never need maintenance.

Page 8



Comfort and Serviceability You Deserve.

The operator's station provides a comfortable and user friendly environment that promotes productive operation. Simplified service access and extended service intervals minimize maintenance time and increase machine production.

Five Amplitude Vibratory System

The pod-style vibratory system delivers optimum compactive force while offering serviceability advantages.

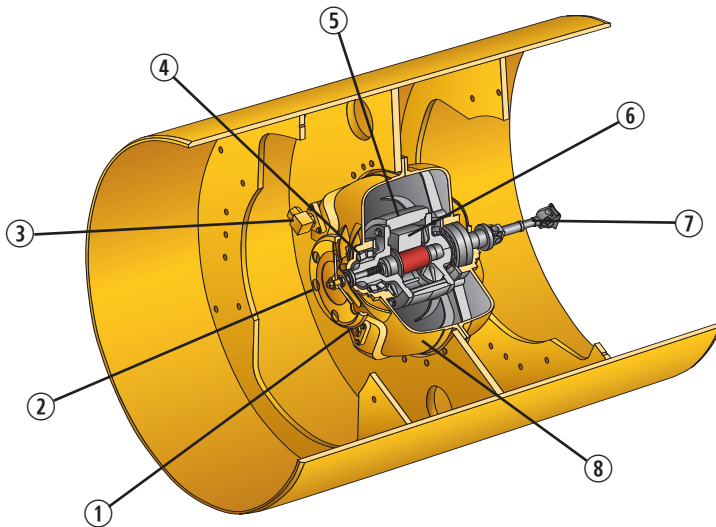

- | | |
|-----------------------------------|-------------------------------|
| 1 Oil Level Sight Gauge | 5 Fixed Eccentric Weight |
| 2 Amplitude Selection Wheel | 6 5-Position Counterweight |
| 3 Oil Drain | 7 Weight Drive Shaft to Motor |
| 4 Eccentric Weight Shaft Bearings | 8 Eccentric Weight Housing |

Five Amplitude Selections

The five amplitude selections provide efficient operation on thick or thin lift applications.

Automatic Corresponding Rotation

Eccentric weight rotation automatically matches drum rotation providing good mat quality.

Automatic Vibration Control

The vibratory system automatically starts when the propel lever is moved from neutral and stops when positioned in neutral. A manual vibratory control is also provided.

3 Year/3000 Hour Service Interval

Moving parts are separated from lubricating oil keeping oil clean to ensure long bearing life. Bearing oil has a 3 year/3000 hour service interval.

Versa Vibe™ Vibratory System

The Versa Vibe vibratory system provides high amplitude or high frequency in one machine for maximum versatility.

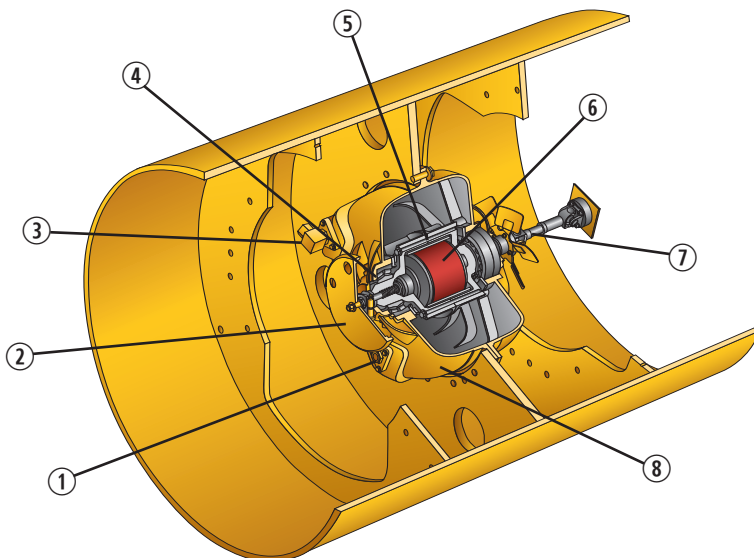

- | | |
|-----------------------------------|-------------------------------|
| 1 Oil Level Sight Gauge | 5 Eccentric Weight |
| 2 Amplitude Selection Wheel | 6 2-Position Counterweight |
| 3 Oil Drain | 7 Weight Drive Shaft to Motor |
| 4 Eccentric Weight Shaft Bearings | 8 Eccentric Weight Housing |

Four Amplitudes and Two Frequencies

Versa Vibe offers four amplitude selections and two frequencies of 42 Hz (2,520 vpm) and 63.3 Hz (3,800 vpm) for customers who value both high amplitude and high frequency in one machine.

Vibratory Control Switch

The vibratory control switch on the console allows the operator to change vibe settings on-the-run from aggressive high amplitude to fast high frequency.

Counter-Rotating Weights

The eccentric weights in the front and rear drums counter-rotate from each other, one eccentric weight is always rotating in the direction of travel.

Automatic Vibration Control

The vibratory system automatically starts when the propel lever is moved from neutral and stops when positioned in neutral.

CB-564D

The CB-564D offers a wider drum and the Versa Vibe™ vibratory system for increased production and versatility.



Wider Drum Width

The CB-564D incorporates a drum width of 2.13 m (84") and a drum diameter of 1300 mm (51") providing increased lane coverage resulting in fewer passes.

Operating Weight

The operating weight of the CB-564D is 12 600 kg (27,783 lb) providing a high centrifugal force of 112.6 kN (25,305 lb)

Versa Vibe™ Vibratory System

The CB-564D is equipped with the Versa Vibe vibratory system which includes two frequencies of 63 Hz (3,800 vpm) and 42 Hz (2,520 vpm). The Versa Vibe system provides high frequency for thin lifts or high amplitude for demanding Superpave mixes.

Caterpillar 3054C Diesel Engine

High-tech four-cylinder engine provides outstanding performance and reliability.

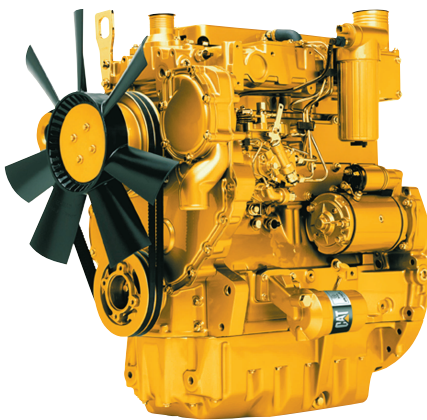

Cat® 3054C Engine

The 3054C engine produces 97 kW (130 hp) of power at 2,200 rpm providing fuel efficiency.

Turbocharged for Top Performance

The turbocharged engine provides efficient operation especially at high altitudes, up to 2500 meters (8,200 feet) without derating.

Balanced Power

The Pressure Override (POR) valve balances power demand in order to provide responsiveness.

Power Draw Comparison

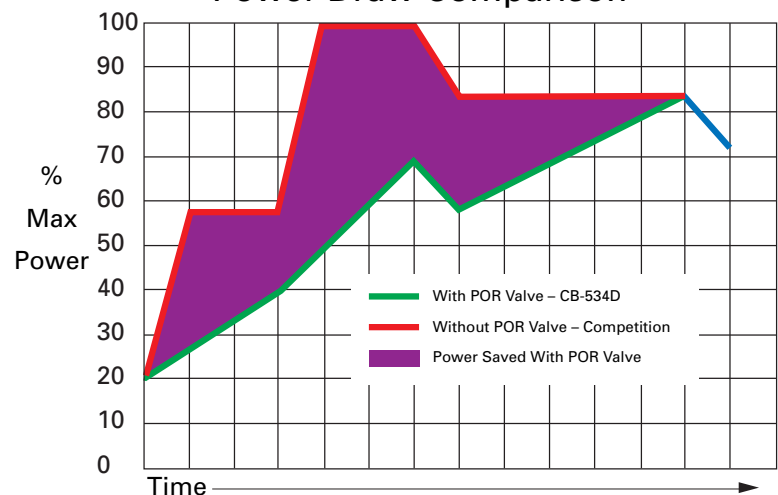

Operator's Station

Ergonomically designed for maximum operator productivity and unmatched comfort.



For FOPS protection to be effective, the operator must be seated under the canopy.

Comfortable Operating Environment

The console and instrumentation move with the operator, staying in the same relative position to the operator.

Multi-Position Operator's Station

The operating station has nine rotating and seven sliding positions, maximizing comfort.

Multi-Function Propel Handle

The multifunction propel handle simplifies operation with the following controls: propel speed, vibrate on/off, water spray on/off, horn and optional drum offset.

Steering Console

The entire console tilts for simple entrance and exit. A lockable vandal cover is provided for the console.

Comfortable and Durable Seat

The seat has adjustable fore/aft position, suspension stiffness, and flip-up arm rests with a 76 mm (3") wide retractable seat belt.

Automatic Speed Control Dial



Isolated Operator's Station

The operator's station with four, heavy-duty rubber mounts reduce machine vibration to the operator.

Automatic Speed Control

A speed control dial located on the operator's console simplifies operation by allowing the operator to preset the machine speed or impact spacing.

The speed control dial allows the operator to push the propel lever to the forward or reverse positions while repeating the desired speed or impact spacing.



Water Spray System

Corrosion-proof system and long-life components for reliable operation.



- 1 Single Water Fill Port
- 2 Spray Nozzle with Filter
- 3 Water Distribution Mat

- 4 Water Filter
- 5 Water Pumps
- 6 Single Water Tank Drain

High-Capacity Water Tank

The single, high capacity, polyethylene water tank is enclosed within the machine frame providing extended operation.

Two Pump System

An auto pump control setting selects water from one pump while traveling forward and water from the other pump while traveling rearward. The system maintains even pump usage for uniform life. Manual override control is provided.

Triple Water Filtration

Water filtration reduces machine downtime caused by system clogs. A mesh strainer is located in the water fill port. The water pump and spray nozzles, include screen filters that provide simple access and cleaning.

Nozzle Orientation

The upward spray nozzle orientation allows water to drain back into the supply line, limiting particle accumulation in the nozzle filter.

Constant or Intermittent Spray Capability

The water spray system provides constant or intermittent spray settings. The intermittent spray setting provides longer operation between fill-ups. The intermittent spray is infinitely variable allowing fine-tuning for any condition.

On/Off Spray Control

The spray control is located on the propel lever providing simple operation.

Quick Release Spray Bars Covers

Quick release spray bar covers shield the spray bars and nozzles from wind and sun, allowing the spray nozzles to provide consistent coverage across the drum surface.

Freeze Protection Kit (Optional)

The freeze protection kit includes an in-line antifreeze bottle that allows the operator to pump antifreeze into the system.

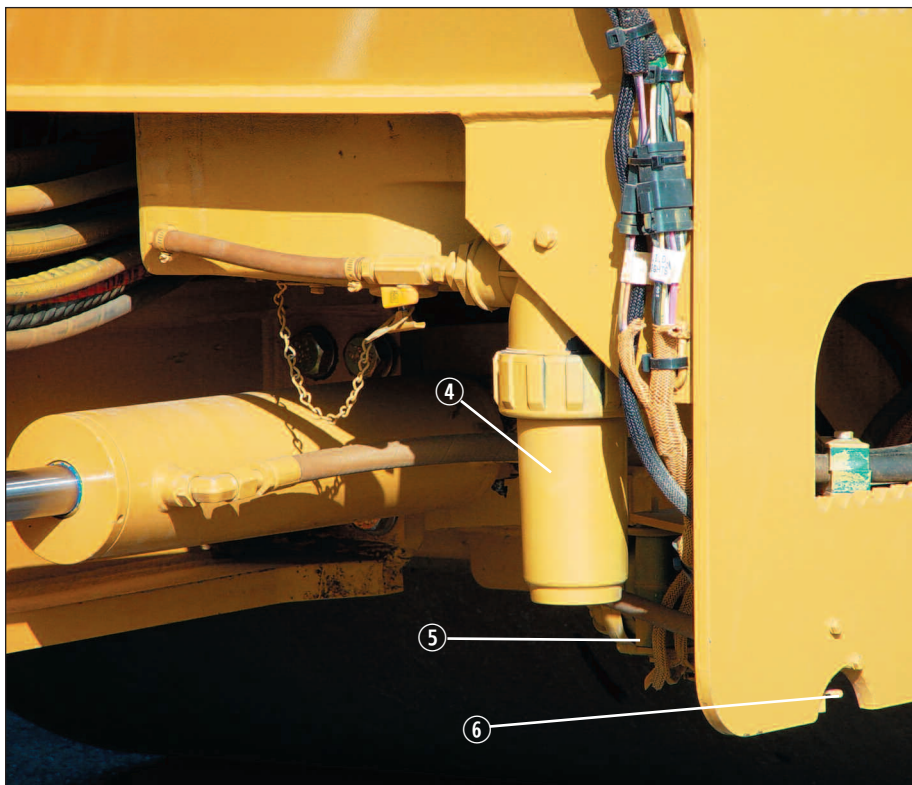

Visibility

The CB-500 D-Series Asphalt Compactors provide good visibility for precise control and operator comfort.



Multi-Position Seating

The multi-position operator's station provides good visibility to the drum edges, drum surfaces, water spray nozzles and overall visibility around the machine.

Folded Drum Supports

Vertically folded drum supports provide the operator with good sight lines to the drum edges when working near obstructions.

Backlit Spray Nozzles

The water spray nozzles include LED lights for easy on/off determination in various lighting conditions.

Reliability and Serviceability

The CB-500 D-Series Asphalt Compactors continue to provide exceptional reliability and serviceability that you've come to expect from Caterpillar.



Vertical-Lift Hood Arrangement

The vertical-lift hood allows routine service when parked close to other machines and structures, providing easy ground level access to routine maintenance points.

Easy Access and Removal

The filters and spray nozzles are easily removed by hand without the need for special tools.

Sealed Hitch Design

The sealed hitch design simplifies overall machine maintenance.

Product Link Ready

The Product Link System ensures maximum uptime and minimum repair costs by simplifying tracking of equipment fleets. The system provides automatic machine location and hour updates.

Engine

The Caterpillar® 3054C engine is a four cylinder, turbocharged, diesel engine. The engine meets U.S. EPA Tier 2 and E.U. Stage II engine emission regulations.

Engine	Cat® 3054C	
Gross Power	kW	hp
SAE J1995	97	130
Net Power	kW	hp
ISO 9249	93	125
EEC 80/1269	93	125
SAE J1349	92	124

Specifications

Bore	105 mm	4.12"
Stroke	127 mm	5.0"
Displacement	4.4 L	268 in ³

- The power ratings apply at a rated speed of 2200 RPM when tested under the reference conditions for the specific standard.
- The net power advertised is the power available at the flywheel when the engine is equipped with alternator, air cleaner, muffler and fan at minimum speed.
- Derating is not required up to an altitude of 2134 m (7,000 ft).
- 12-volt electrical starting system with 80 amp alternator and one, 12-volt, 950 cold cranking amp, maintenance-free battery.

Transmission

Variable displacement piston pump supplies pressure flow to two-speed hydraulic motors driving the front and rear drums through planetary gearboxes. A single propel lever located on the control console provides smooth hydrostatic control of the machine's infinitely variable speeds in both forward and reverse. When the propel lever is positioned in reverse, a backup alarm emits an audible alarm.

Speeds (forward and reverse):

Low	0-7.3 km/h	0-4.5 mph
High	0-13 km/h	0-8 mph

Brakes

Service Brake Features

- Closed-loop hydrostatic drive system provides dynamic braking during machine operation.

Secondary Brake Features

- Spring-applied/hydraulically released brake on front and rear drums. Actuated by switch on console or automatically when pressure is lost in brake circuit or when the engine is shut off. A manual release pump is included.

Steering

Priority-demand hydraulic power-assist steering system provides smooth, firm machine handling. The automotive-type steering wheel and column are integral with the operator's swivel platform and allow steering from multiple positions.

Minimum turning radius:

Inside drum edge			
CB-534D	4.15 m	13' 8"	
CB-534D XW	4.0 m	13' 1"	
CB-564D	3.94 m	12' 11"	

Outside drum edge

CB-534D	5.85 m	19' 2"	
CB-534D XW	6.0 m	19' 8"	
CB-564D	6.07 m	19' 11"	

Steering Angles 40°

Frame

Fabricated from heavy gauge steel plate and rolled sections. The frame is joined at the articulation pivot. 50% of the machine is rear of the articulation pivot and 50% is in front of the pivot. The two sections are joined by two hardened steel pins that are supported by heavy-duty roller bearings. A vertical pin provides a $\pm 40^\circ$ steering angle and the frame/yoke provides $\pm 4^\circ$ oscillation for a smooth ride, uniform drum loading and no maintenance interval.

Instrumentation

The instrument panel is located in front of the operator and contains the speedometer, vibrate tachometer, vibration mode selector, light switches, hour meter, alternator indicator light, fuel gauge, water tank gauge and warning lights. An audible alarm sounds and a warning light illuminates if abnormal conditions occur in engine oil pressure, engine coolant temperature or charge pressure. Operational lights are also positioned on the instrument panel. They illuminate if the vibratory system, drum spray system, neutral or parking brake are engaged.

Machine controls are also located to the operator's right on the control console. These controls include the start switch with cold-start aid, electric throttle, propel lever, speed selector switch, automatic speed control (ASC) dial, drum spray switch, vibration switch, horn and secondary brake switch. Electrical system fuses and relays are located on the side of the control console.

Drum Spray System

The entire drum spray system is corrosion-proof and includes a large water tank with a single fill port and drain valve.

The system consists of two diaphragm pumps driven by electric motors. Only one pump operates at a time, supplying pressurized water to both sets of drum spray bars. The pump operation is controlled from operator's station. The system provides complete back-up capability controlled from operator's station.

Spray can be set on continuous for maximum wetting action or intermittent for maximum duration between fill-ups. The "Auto" selection pulls water from one pump traveling forward and from the other pump while traveling backward. The spray nozzles on the drum can be easily removed for replacement or cleaning without the need for tools.

Five Amplitude Vibratory System

Frequency: 42 Hz (2,520 vpm)

Nominal Amplitude	CB-534D (Standard)		CB-534D XW (Standard)	
	mm	in	mm	in
High	1.05	0.041"	0.86	0.034"
Medium-high	0.91	0.036"	0.75	0.030"
Medium	0.72	0.028"	0.58	0.023"
Medium-low	0.54	0.021"	0.45	0.018"
Low	0.33	0.013"	0.26	0.010"

Centrifugal Force Per Drum

High	112.6 kN	25,208 lb	112.6 kN	25,208 lb
Medium-high	97 kN	21,847 lb	97 kN	21,847 lb
Medium	77 kN	17,285 lb	77 kN	17,285 lb
Medium-low	58 kN	12,964 lb	58 kN	12,964 lb
Low	35 kN	7,922 lb	35 kN	7,922 lb

Versa Vibe™ Vibratory System

Frequency: 42 Hz (2,520 vpm)

Nominal Amplitude	CB-534D (Optional)		CB-534D XW (Optional)		CB-564D (Standard)	
	mm	in	mm	in	mm	in
High	0.86	0.034"	0.73	0.029"	0.67	0.026"
Low	0.73	0.029"	0.62	0.024"	0.57	0.022"

Centrifugal Force Per Drum

High	98.9 kN	22,234 lb	98.9 kN	22,234 lb	98.9 kN	22,234 lb
Low	82.6 kN	18,570 lb	82.6 kN	18,570 lb	82.6 kN	18,570 lb

Frequency: 63.3 Hz (3,800 vpm)

Nominal Amplitude	CB-534D (Optional)		CB-534D XW (Optional)		CB-564D (Standard)	
	mm	in	mm	in	mm	in
High	0.44	0.017"	0.37	0.015"	0.34	0.013"
Low	0.30	0.012"	0.25	0.010"	0.23	0.009"

Centrifugal Force Per Drum

High	112.6 kN	25,305 lb	112.6 kN	25,305 lb	112.6 kN	25,305 lb
Low	76.7 kN	17,227 lb	76.7 kN	17,227 lb	76.7 kN	17,227 lb

Dual Amplitude and Dual Frequency Vibratory System

Frequency: 42 Hz (2,520 vpm)

Nominal Amplitude	CB-534D (Optional)		CB-534D XW (Optional)	
	mm	in	mm	in
Nominal Amplitude	0.83	0.033"	0.67	0.026"
Centrifugal Force	93.0 kN	20,925 lb	93.0 kN	20,925 lb

Frequency: 63.3 Hz (3,800 vpm)

Nominal Amplitude	CB-534D (Optional)		CB-534D XW (Optional)	
	mm	in	mm	in
Nominal Amplitude	0.34	0.013"	0.27	0.010"
Centrifugal Force	36.0 kN	8,100 lb	36.0 kN	8,100 lb

Dimensions and Weights

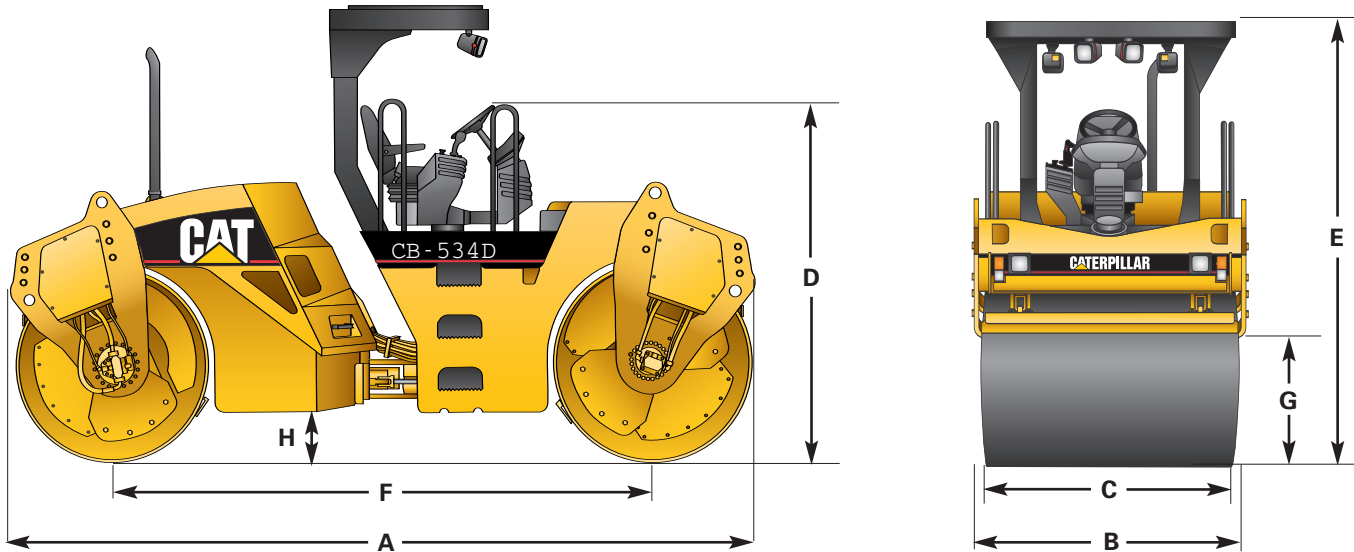

Dimensions	CB-534D		CB-534D XW		CB-564D	
Overall length (A)	4.94 m	16' 2"	4.94 m	16' 2"	4.94 m	16' 2"
Overall width (B)	1.88 m	6' 2"	2.18 m	7' 2"	2.31 m	7' 6"
Drum width (C)	1.70 m	67"	2.0 m	79"	2.13 m	84"
Drum shell thickness	18 mm	0.71"	18 mm	0.71"	18 mm	0.71"
Drum diameter	1.3 m	4' 3"	1.3 m	4' 3"	1.3 m	4' 3"
Height at steering wheel (D)	2.32 m	8' 8"	2.32 m	8' 8"	2.32 m	8' 8"
Overall height at ROPS/FOPS (E)	3.05 m	10'	3.13 m	10' 3"	3.13 m	10' 3"
Wheelbase (F)	3.64 m	11' 11"	3.64 m	11' 11"	3.64 m	11' 11"
Curb clearance (G)	870 mm	34.5"	870 mm	34.5"	870 mm	34.5"
Ground clearance (H)	306 mm	12"	306 mm	12"	306 mm	12"

Operating Weights (with ROPS/FOPS)

Standard Machine	10 380 kg	22,836 lb	11 300 kg	24,860 lb	12 600 kg	27,783 lb
at front drum	5066 kg	11,170 lb	5712 kg	12,595 lb	6340 kg	13,980 lb
at rear drum	4942 kg	10,897 lb	5588 kg	12,322 lb	6260 kg	13,803 lb
Maximum machine	11 297 kg	24,853 lb	12 217 kg	26,877 lb	13 507 kg	29,715 lb
Static linear load (at drum)	29.4 kg/cm	164 lb/in	28.3 kg/cm	158 lb/in	29.6 kg/cm	165 lb/in

* Maximum machine weight includes all attachments, full fluids and an 80 kg (175 lb) operator.

* Standard operating weights include lubricants, coolant, 80 kg (175 lb) operator, full fuel tank, full hydraulic system and 1/2 full water tank.

Optional Equipment

- Versa Vibe™ Vibratory System
- Dual Amplitude and Dual Frequency Vibratory System (CB-534D, CB-534D XW)
- Offset Hitch (CB-534D, CB-534D XW)
- Water Distribution Mats
- Cocoa Mats
- Water Spray Freeze Protection Kit
- Drum Covers
- High Intensity Discharge Lights
- Warning Beacon
- External Mirrors
- Brass Water Spray Nozzles

Service Refill Capacities

	Liters	Gallons
Fuel Tank	219	58
Cooling System	19.5	5
Engine Oil (w/filter)	9	2.4
Vibratory Bearing Lubrication	20	5.3
Hydraulic Tank*	60	15.8
Water (Spray) Tank	1100	290

* Figures describe tank at "full" level. Actual tank capacity is higher. Hydraulic/Charge oil is filtered by a 10 micron charge oil filter.

Caterpillar offers a comprehensive line of vibratory asphalt compactors.

Contact your local Caterpillar dealer to learn more about the complete line of Caterpillar's Paving Products.

12 Ton



CB-634D

Operating Weight (with ROPS)	12 800 kg	28,160 lb
Drum Width	2.13 m	84"
Frequency	44 Hz	2,640 vpm
Centrifugal Force		
Maximum	159 kN	35,745 lb
Minimum	58 kN	13,039 lb
Gross Power	108 kW	145 hp

12 Ton



CB-564D

Operating Weight (with ROPS)	12 600 kg	27,783 lb
Drum Width	2.13 m	84"
Frequency	42/63 Hz	2,520/3,800 vpm
Centrifugal Force		
Maximum	112.6 kN	25,208 lb
Minimum	35 kN	7,922 lb
Gross Power	97 kW	130 hp

11 Ton



CB-534D XW

Operating Weight (with ROPS)	11 300 kg	24,860 lb
Drum Width	2.0 m	79"
Frequency	42/63 Hz	2,520/3,800 vpm
Centrifugal Force		
Maximum	112.6 kN	25,208 lb
Minimum	35 kN	7,922 lb
Gross Power	97 kW	130 hp

11 Ton



CB-534D

Operating Weight (with ROPS)	10 380 kg	22,836 lb
Drum Width	1.7 m	67"
Frequency	42/63 Hz	2,520/3,800 vpm
Centrifugal Force		
Maximum	112.6 kN	25,208 lb
Minimum	35 kN	7,922 lb
Gross Power	97 kW	130 hp

© 2005 Caterpillar
All Rights Reserved.
www.cat.com

Featured machines in photography may include optional equipment.
Materials and specifications are subject to change without notice.

QEHQ1211 (10/05)
Replaces QEHQ9978-01 and QEHQ9960

CAT, CATERPILLAR, their respective logos and "Caterpillar Yellow", as well as corporate and product identity used herein, are trademarks of Caterpillar and may not be used without permission.

CATERPILLAR®