

24M

Motor Grader



Engine

Engine Model	Cat® C18 ACERT™	
Base Power (all gears) – Net	397 kW	533 hp
Base Power (all gears) – Net (Metric)		540 hp

Moldboard

Width	7.3 m	24 ft
-------	-------	-------

Weights

Gross Vehicle Weight – Typically Equipped	65 840 kg	145,141 lb
---	-----------	------------

Features

Operator Station

A revolutionary cab design gives you unmatched comfort, visibility and ease of use, so your operators can be more confident and productive.

Structures, Drawbar, Circle and Moldboard

Durable structures with fast and simple DCM adjustments save you service time. Shims and wear strips save you money and make it easy to maintain factory tightness of components for better grading results.

Hydraulics

Load sensing, proportional hydraulics mean operators can rely on consistent power. This precise, predictable implement response will save time and help assure quality work.

Integrated Technologies

Grade control and machine monitoring technologies help you improve grading efficiency and enhance fleet management for improved machine utilization.

Safety

The safety of your operators and those on the job site is key in the design of every Cat machine. Features like outstanding visibility, Operator Not Present Monitoring System and redundant steering and braking systems help you meet your goals of getting everyone home safely at the end of each work day.

Contents

Operator Station.....	4
Steering and Implement Controls	5
Engine	6
Power Train.....	7
Structures and Drawbar-Circle-Moldboard....	8
Hydraulics	9
Integrated Technologies.....	10
Safety	12
Serviceability and Customer Support.....	14
Sustainability	15
Specifications.....	16
Standard Equipment.....	20
Optional Equipment.....	21





The M Series Motor Grader represents a revolution in operational efficiency and overall productivity. The 24M is designed to help you build and maintain the haul roads needed to support maximum efficiency in large mining operations. The 24M has set a new standard of quality to maximize your return on investment.



Operator Station

Comfort, productivity, advanced technology

Visibility

Good visibility is key to your safety and efficiency. Large windows make it easy to see the moldboard and tires, as well as behind the machine. The front frame, lift arms and rear enclosure are coated with glare reducing paint to help you operate more safely at night. Available front and rear facing cameras further enhance lines of sight all around the machine.

Comfort and Control

Experience the most spacious, comfortable cab in the industry. Revolutionary joystick controls replace levers, so hand and arm movement is reduced by 78%, leaving operators much less fatigued at the end of the day. Rocker switches and control levers are in easy reach.

A standard Cat® Comfort Series suspension seat and arm/wrist rests are fully adjustable for even more comfort and productivity. Multiple isolation mounts significantly reduce sound and vibration for a more relaxed work environment.

The high capacity Heating, Ventilation and Air Conditioning (HVAC) system dehumidifies and pressurizes the cab, circulates fresh air, seals out dust and keeps windows clear.

Available Bluetooth technology enables streaming audio from a portable device and hands-free use of a mobile phone while operating machine.

In-Dash Instrument Cluster

Easy-to-read, high-visibility gauges and warning lamps keep you aware of critical system information. Cat Messenger offers real-time machine performance and diagnostic data to help you get the most from your machine.

Steering and Implement Controls

Unprecedented precision and ease of operation



Operators are more comfortable and productive with two electro-hydraulic joysticks. New and experienced operators around the world report that the controls are easy to learn, and that the electronically adjustable control pods help position them for optimal comfort, visibility and proper operation.

Joystick Functions

The left joystick controls steering, articulation, return-to-center, wheel lean, gear selection, left moldboard lift cylinder and float.

The right joystick controls drawbar, circle and moldboard functions as well as electronic throttle control and manual differential lock/unlock.

Joystick lean angle mirrors the steer tires' turning angle. A brake tensioning system holds the joystick in position until the operator moves it. The steering control automatically reduces steering sensitivity at higher ground speeds for predictable control. Infinitely variable roller switches control of the rear ripper and/or front lift group (when equipped).



Electronic Throttle Control

Provides easy, precise and consistent throttle operation. An automatic/manual mode switch offers flexibility for different applications and operator preferences.

Articulation Return-to-Center

Automatically returns the machine to a straight frame position from any angle with the touch of a button.

Engine

Power and reliability



The Cat C18 engine with ACERT™ Technology gives you the performance you need to maintain consistent grading speeds for maximum productivity. Superior torque and lugging capability provide the power to pull through sudden, short-term increases in loads.

ACERT Technology lowers combustion chamber temperatures and optimizes fuel combustion to generate more work output for your fuel cost. ACERT engines also generate fewer emissions to meet the needs of operations around the world.

Hydraulic Demand Fan

The hydraulic demand fan automatically adjusts the cooling fan speed according to engine cooling requirements. When cooling demand is reduced, you benefit from more power to the ground and improved fuel efficiency.

Compression Brake

The standard three-phase compression brake enables higher travel speeds downhill, while reducing wear on brake components. This improves overall productivity and lowers your maintenance costs.

Ether Starting Aid

A standard ether starting aid feature helps cold-weather startups in extreme temperatures.



Power Train

Maximum power to the ground

We designed the 24M to give you efficiency and longevity in your most demanding applications.

- Full Electronic Clutch Pressure Control (ECPC) system optimizes inching modulation for smooth shifts and directional changes, reducing stress on gears.
- Standard Programmable Autoshift simplifies operation by allowing the operator to program the transmission to shift at optimal points to match your application.
- Lockup Clutch Torque Converter permits the machine to operate in direct drive for more efficient operation at higher engine speeds and in converter mode for more low end torque.
- Six forward and three reverse gears are specifically designed to give you a wide operating range for maximum productivity in all mining applications.
- Balanced Planetary Transmission provides superior load distribution and heat dissipation for longer transmission life.
- Engine Over-Speed Protection prevents downshifting until an acceptable safe travel speed has been established.

Front and Rear Axles

The sealed spindle keeps front axle bearings lubricated and protected from contaminants. The Cat "Live Spindle" design places the larger tapered roller bearing on the outside, where the load is greater, extending bearing life.

A bolt-on modular rear axle improves serviceability and contamination control with easy access to differential components.

Hydraulic Brakes

Oil-bathed multi-disc service brakes are hydraulically actuated for smooth, predictable braking and lower operating costs. Brakes are located at each tandem wheel for a large total brake surface area to give you dependable stopping power and longer life.

Structures and Drawbar-Circle-Moldboard

Service ease and precise blade control

Caterpillar designs motor grader frame and drawbar components to give you performance and durability in heavy duty applications. The one-piece forged steel circle stands up to high stress loads, and a sacrificial wear system helps keep your service time and costs down.

The articulation hitch features a large tapered roller bearing to carry loads evenly and smoothly. It is sealed to prevent contamination and a locking pin prevents articulation for safety during service or transport.

Blade Angle and Moldboard

An aggressive blade angle helps you work more efficiently by allowing material to roll more freely along the blade.

The moldboard features heat-treated rails, hardened cutting edges and end bits, and heavy duty bolts to give you greater reliability and long service life. Optimized moldboard curvature and large throat clearance help you move material more efficiently.

Easy Maintenance for More Uptime

A series of shims, patented top-adjust wear strips and wear inserts are easy to add or replace. This keeps drawbar-circle-moldboard components factory-tight for higher quality work, and saves you service time and costs.

An adjustable rear circle drive reduces service time and reduces wear by keeping components light. Six bolt-on tooth segments on the circle can be individually replaced to reduce cost and downtime for maintenance.



Hydraulics

Advanced machine control

State-of-the-art electro-hydraulics give you advanced machine controls with precise and predictable movements.

Load Sensing Hydraulics (PPPC)

A proven load-sensing system and advanced Proportional Priority Pressure-Compensating (PPPC) electro-hydraulic valves give you superior implement control and enhanced machine performance. Continuously matching hydraulic flow/pressure to power demands creates less heat and reduces power consumption.

- Consistent, Predictable Movement – PPPC valves have different flow rates for the head and rod ends of the cylinder, so you can count on consistent, predictable implement response.
- Balanced Flow – Hydraulic flow is proportioned to give you confidence that all implements will operate simultaneously without slowing the engine or speed of some implements.



Blade Float

Allows the blade to move freely under its own weight. By floating both cylinders, the blade can follow the contours of the haul road. Floating only one cylinder permits the toe of the blade to follow a hard surface while the operator controls the slope with the other lift cylinder. An optional Variable Down Pressure feature allows you to select the amount of down force when the blade is in float. This helps you extend cutting edge life and is effective for removing snow and mud from a road surface.

Independent Oil Supply

Large, separate hydraulic oil supplies prevent cross-contamination and provide proper oil cooling, which reduces heat build-up and extends component life. Cat XT™ hose allows high pressures for maximum power and reduced downtime.

VIMS™

VIMS uses on-board sensors to monitor a wide range of vital machine functions. If an abnormal condition is detected, it will alert the operator and instruct them to take appropriate action. This improves availability, component life and production while reducing repair cost and the risk of a catastrophic failure.

Cat Grade Control Cross Slope

Cross Slope is a fully integrated, factory installed system that helps your operator more easily achieve the desired cross slope by automating one end of the blade. The system is scalable, supporting all two- and three-dimensional upgrades to be fully compatible with all AccuGrade™ kits.

Cat MineStar™ System

Cat MineStar System is the industry's broadest suite of integrated mine operations and mobile equipment management technologies, configurable to suit your operation's needs.

- **Fleet** provides real-time machine tracking, assignment and productivity management, giving you a comprehensive overview of all operations from anywhere in the world.
- **Terrain** enables high-precision management of drilling, dragline, grading and loading operations through the use of guidance technology. It increases machine productivity and provides you real-time feedback for improved efficiency.
- **Detect** helps increase operator awareness, enhancing safety at your operation. It includes a range of capabilities designed to assist the operator with areas of limited visibility around fixed and mobile equipment.
- **Health** works to minimize unscheduled downtime and productivity loss, plus helps you keep your operating costs in check by streamlining service and maintenance management.

For additional information, please see your Cat dealer or visit mining.cat.com/miningtechnology.



Integrated Technologies

Solutions to make work easier and more efficient



Cat Product Link*

Remote monitoring with Product Link improves your overall fleet management effectiveness. Events, diagnostic codes and data like hours, fuel, idle time are transmitted to a secure web based application, VisionLink™. VisionLink includes powerful tools to convey information to you and your Cat dealers, including mapping, working and idle time, fuel level and more.

*Product Link licensing not available in all areas. Please consult your Cat dealer for availability.



Safety

Designed with protection in mind



Operator Not Present Monitoring System

Keeps the parking brake engaged and hydraulic implements disabled until the operator is initially seated and the machine is ready for operation.

Speed Sensitive Steering

Makes steering less sensitive as ground speed increases for greater operator confidence and control.

Secondary Steering System

Automatically engages a mechanical pump driven by transmission output so the operator can steer the machine to a stop.

Hydraulic Lockout

Disables all implement functions while still providing machine steering control. This safety feature is especially useful while roading.

Brake Systems

Brakes are located at each tandem wheel to eliminate braking loads on the power train. Redundant brake systems utilize accumulators to enable stopping in case of engine failure.

Walkways and Grab Rails

Perforated steel tandem walkways and conveniently located grab rails offer a sturdy platform and support for moving on, off and around the machine. Lighting can be activated from ground level and turned off via in-cab switch.



Object Detection

Optional camera and radar system alerts operator via an in-cab display if any objects are in close proximity when the machine is in reverse. The scalable system allows cameras and a display to be installed initially and radar to be added later for additional functionality.

Front and Rear Cameras

Cameras with in-cab monitors are available to further enhance lines of sight to help increase operator awareness of their surroundings.

Circle Drive Slip Clutch

Protects the drawbar, circle and moldboard from shock loads when the blade encounters an immovable object. This standard feature also reduces the possibility of abrupt directional changes in poor traction conditions.

Blade Lift Accumulators

Help absorb impact loads to the moldboard by allowing vertical blade travel. This standard feature helps reduce unnecessary wear and also help reduce impact loading for enhanced operator safety.



Other Safety Features

- Grouped, ground level service points
- Laminated front window glass
- Optional LED Lighting
- Ground-level electrical disconnect switch
- Ground-level engine shutoff switch
- Optional window cleaning platform
- Dual exits
- Auxiliary equipment mounting area
- Glare reducing paint for night operation

Serviceability and Customer Support

When uptime counts

Cat motor graders are designed to help customers increase uptime and reduce costs. Grouped service points and extended service intervals save maintenance time. A standard Automatic Lubrication System maintains proper grease on working surfaces, increasing component life and purging contaminants from pins and bushings to help prevent damage. Standard Fast-Fill allows customers to refuel in less than four minutes to get back on the job quickly.

Advanced Diagnostics

- Cat VIMS monitors vital machine functions and alerts the operator if action is needed.
- Cat Messenger, combined with full systems integration, enhances diagnostic capability for quick analysis of critical data.
- Electronic Technician (Cat ET) lets service technicians access stored diagnostic data and configure machine parameters through the Cat Data Link.
- Low Battery Elevated Idle raises idle speed when low system voltage is detected, ensuring adequate system voltage and improving battery reliability.
- Automatic Engine Deration protects the engine and aftertreatment by automatically lowering engine torque output and alerting the operator if critical conditions are detected.

Unparalleled Dealer Support

When it comes to supporting customers, especially in remote or challenging conditions, Cat dealers are second to none. From machine selection and purchase to maintenance support and rebuilds, Cat dealers have the experience and capabilities to keep customers up and running.

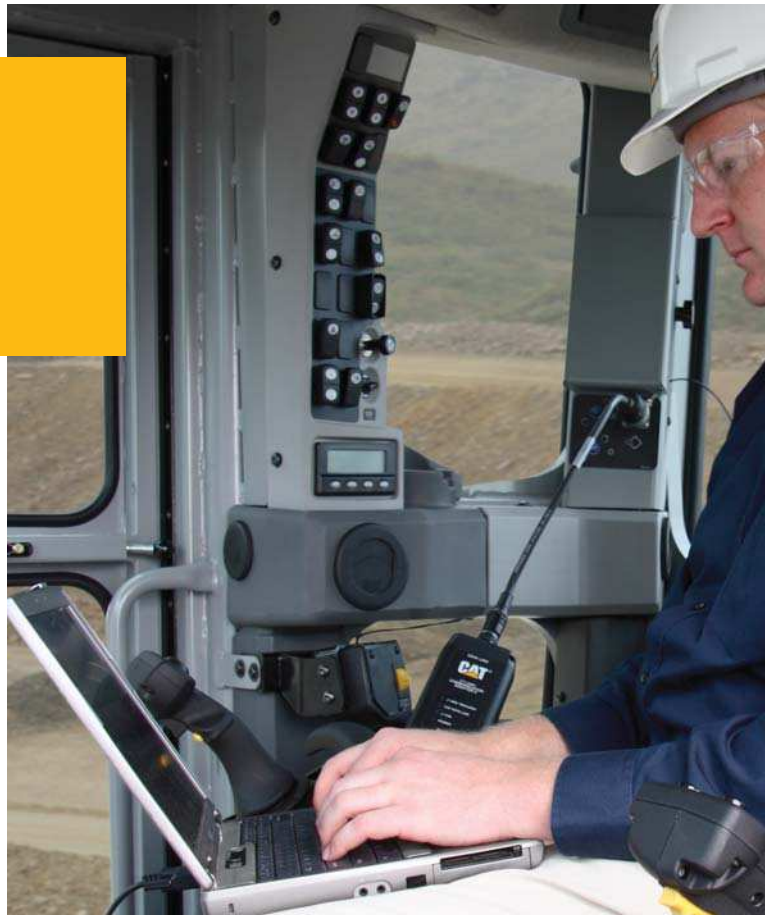

Sustainability

Thinking generations ahead



Fuel Efficiency

- ACERT™ engine technology helps improve fuel efficiency. The 24M motor grader is 5–8 percent more fuel efficient* than the 24H.
- Integrated machine systems and technologies improve productivity for greater accuracy, lower fuel use and reduced machine wear.

Green House Gas Emissions

- Reduced fuel consumption means reduced CO₂ emissions.

Material Efficiency and Life Cycle Costs

- Replaceable wear parts save maintenance time and cost, and extend major component life.
- Major components are built to be rebuilt, eliminating waste and saving customers money by giving the machine and/or major components a second – and even third – life.
- Machine is built with a 97% recyclability rate (ISO 16714) to conserve valuable natural resources and further enhance machine end-of-life value.

Sound

- Reduced engine noise and quieter cabs mean lower operator and spectator sound levels.

Safety and the Environment

- Ecology drains help make draining fluids more convenient and help prevent spills.
- Cartridge style fluid filters provide safe clean draining of filters prior to replacement – helping to prevent fluid spills.
- A variety of safety features help safeguard operators and others on the job site.

**Fuel efficiency and productivity estimates may vary based on application, operator, operating conditions and other factors influencing machine performance.*

24M Motor Grader Specifications

Engine – U.S. EPA Tier 4 Interim Certified*

Base Power (all gears) – Net	397 kW	533 hp
Base Power (all gears) – Net (Metric)		540 hp
Engine Model	Cat® C18 ACERT™	
Displacement	18.1 L	1,104.5 in ³
Bore	145 mm	5.7 in
Stroke	183 mm	7.2 in
Maximum Torque	2389 N·m	1,762 ft-lb
Speed @ Rated Power	1,800 rpm	
Number of Cylinders	6	
Derating Altitude	1676 m	5,500 ft
Standard – Fan Speed		
Maximum	1,325 rpm	
Minimum	60 rpm	
Standard – Ambient Capability	50° C	122° F

* For U.S. and Canada, meets EPA/ARB Flexibility Engine or EPA/ARB Tier 4 Interim AB&T certified engine (Tier 3, credit using engine). For EU, meets EU Stage IIIA certified engine.

Note: For all other regulated regions, engine meets non-current U.S. EPA Tier 3 and EU Stage IIIA emission standards.

- Net power is tested per ISO 9249, SAE J1349, and EEC 80/1269 standards in effect at the time of manufacture.
- Net power advertised is the power available at a rated speed of 1,800 rpm, measured at the flywheel when engine is equipped with fan running at minimum speed, air cleaner, muffler and alternator.
- Power as declared per ISO 14396 is 398 kW.

Engine – Tier 0*

Base Power (all gears) – Net	397 kW	533 hp
Base Power (all gears) – Net (Metric)		540 hp
Engine Model	Cat C18 ACERT	
Displacement	18.1 L	1,104.5 in ³
Bore	145 mm	5.7 in
Stroke	183 mm	7.2 in
Maximum Torque	2389 N·m	1,762 ft-lb
Speed @ Rated Power	1,800 rpm	
Number of Cylinders	6	
Derating Altitude	3048 m	10,000 ft
Standard – Fan Speed		
Maximum	1,325 rpm	
Minimum	60 rpm	
Standard – Ambient Capability	50° C	122° F

* For all non-regulated regions, engines suitable for regions not subjected to any emission regulations.

- Net power is tested per ISO 9249, SAE J1349, and EEC 80/1269 standards in effect at the time of manufacture.
- Net power advertised is the power available at a rated speed of 1,800 rpm, measured at the flywheel when engine is equipped with fan running at minimum speed, air cleaner, muffler and alternator.
- Power as declared per ISO 14396 is 398 kW.

Power Train

Forward/Reverse Gears	6 Forward/3 Reverse	
Transmission	Automatic, electronic power shift	
Brakes		
Service	Oil-actuated, oil-disc	
Service – Surface Area	101 508 cm ²	15,733 in ²
Parking	Spring applied, hydraulically released	
Secondary	Oil-actuated, oil-disc	

Hydraulic System

Circuit Type	Electro-hydraulic load sensing, closed center	
Pump Type	Variable piston	
Pump Output	537 L/min	142 gal/min
Maximum System Pressure	24 150 kPa	3,500 psi
Standby Pressure	3100 kPa	450 psi

- Pump output measured at 2,100 rpm.

Operating Specifications

Top Speed		
Forward	40.9 km/h	25.4 mph
Reverse	39.2 km/h	24.4 mph
Turning Radius (outside front tires)	12.4 m	40 ft 9 in
Steering Range – Left/Right	47.5°	
Articulation Angle – Left/Right	25°	
Forward		
1st	3.5 km/h	2.2 mph
2nd	5.4 km/h	3.4 mph
3rd	9.2 km/h	5.7 mph
4th	14.2 km/h	8.8 mph
5th	26.4 km/h	16.4 mph
6th	40.9 km/h	25.4 mph
Reverse		
1st	5.2 km/h	3.2 mph
2nd	13.6 km/h	8.5 mph
3rd	39.2 km/h	24.4 mph

- Machine speed measured @ 2,100 engine rpm with 29.5R29 radial tires, no slip.

Service Refill

Fuel Capacity	1326 L	350 gal
Cooling System	90 L	24 gal
Hydraulic System		
Total	264 L	70 gal
Tank	135 L	36 gal
Engine Oil	60 L	16 gal
Transmission Oil	87.1 L	23 gal
Differential/Final Drives	184 L	49 gal
Tandem Housing (each)	322 L	85 gal
Front Wheel Spindle Bearing Housing	4 L	1 gal
Circle Drive Housing (each)	7.5 L	2 gal

Frame

Circle		
Diameter	2631 mm	103.6 in
Blade Beam Thickness	160 mm	6.3 in
Drawbar		
Height	215 mm	8.5 in
Thickness	16 mm	0.6 in
Width	225 mm	8.9 in
Front-Top/Bottom Plate		
Width	514 mm	20.2 in
Thickness	50 mm	2 in
Front-Side Plates		
Width	415 mm	16.3 in
Thickness	25 mm	1 in
Front Axle		
Height to Center	817 mm	32.2 in
Wheel Lean, Left/Right	18°	
Total Oscillation per Side	32°	
Height – Front Axle Center	858 mm	33.8 in

Tandems

Height	1040 mm	41 in
Width	353 mm	13.9 in
Sidewall Thickness		
Inner	25 mm	1 in
Outer	30 mm	1.2 in
Drive Chain Pitch	76 mm	3 in
Wheel Axle Spacing	2285 mm	90 in
Tandem Oscillation		
Front Up	20°	
Front Down	20°	

Moldboard

Width	7.3 m	24 ft
Height	1025 mm	40 in
Thickness	50 mm	2 in
Arc Radius	550 mm	21.7 in
Throat Clearance	162 mm	6.4 in
Cutting Edge		
Width	330 mm	13 in
Thickness	29 mm	1.1 in
End Bit		
Width	203 mm	8 in
Thickness	25 mm	1 in
Blade Pull		
Base	39 236 kg	86,500 lb
Maximum	43 518 kg	95,940 lb
Down Pressure		
Base	31 563 kg	69,583 lb
Maximum	34 316 kg	75,654 lb

24M Motor Grader Specifications

Blade Range

Circle Centershift		
Right	5338 mm	210.2 in
Left	5332 mm	209.9 in
Moldboard Sideshift		
Right	4902 mm	193 in
Left	4528 mm	178.3 in
Maximum Blade Position Angle	35°	
Blade Tip Range		
Forward	40°	
Backward	0°	
Maximum Shoulder Reach Outside of Tires		
Right	3228 mm	127.1 in
Left	3222 mm	126.9 in
Maximum Lift above Ground	634 mm	25 in
Maximum Depth of Cut	657 mm	25.9 in

Ripper

Ripping Depth – Maximum	454 mm	17.9 in
Ripper Shank Holders	7	
Shank Holder Spacing		
Minimum	593 mm	23.4 in
Maximum	604 mm	23.8 in
Penetration Force	13 601 kg	29,985 lb
Pryout Force	18 621 kg	41,052 lb

Weights

Gross Vehicle Weight – Typically Equipped		
Total	65 840 kg	145,141 lb
Front Axle	19 550 kg	43,100 lb
Rear Axle	46 290 kg	102,051 lb

Gross Vehicle Weight – Base		
Total	62 726 kg	138,287 lb
Front Axle	19 131 kg	42,177 lb
Rear Axle	43 595 kg	96,110 lb

Gross Vehicle Weight – Maximum		
Total	69 335 kg	152,856 lb
Front Axle	20 800 kg	45,856 lb
Rear Axle	48 535 kg	107,000 lb

- Typically equipped weight includes base plus ripper, push block, transmission guard, 29.5R29 tires and other equipment.
- Base operating weight calculated on standard machine configuration with 29.5-29 28PR tires, full fuel tank, coolant, lubricants and operator.

Standards

ROPS/FOPS	ISO 3471/ISO 3449
Steering	ISO 5010
Brakes	ISO 3450
Sound	ISO 6394/ISO 6395

- The static operator sound pressure level measured according to ISO 6394 for a cab offered by Caterpillar, when properly installed, maintained and tested with doors and windows closed and hydraulic fan at maximum speed, is 74 dB(A).
- The dynamic spectator sound pressure level is 111 dB(A) when ISO 6395:2008 is used to measure the value of an enclosed cab.

Dimensions

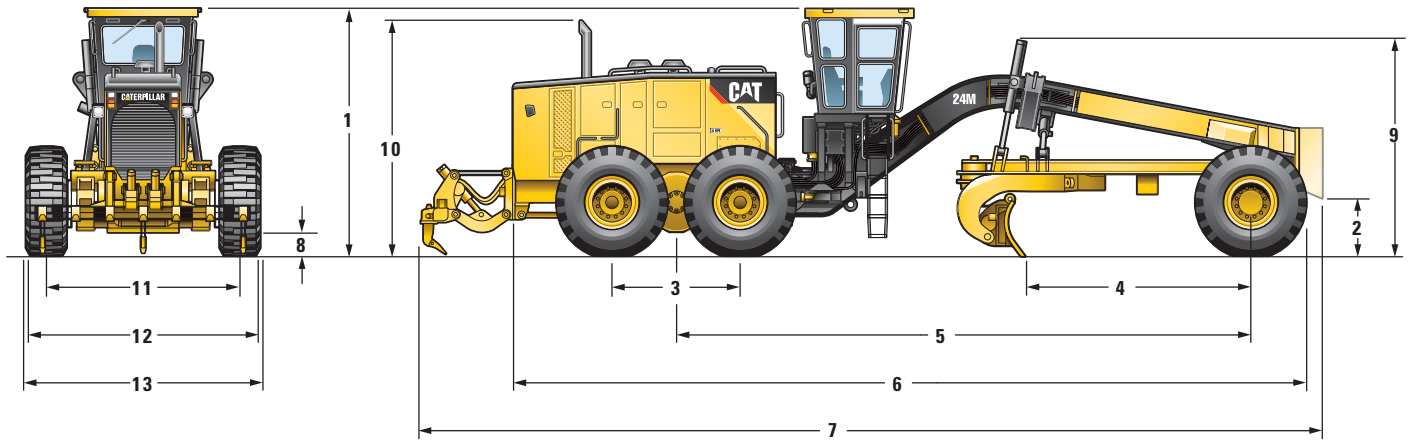

1	Height – Top of Cab	4452 mm	175.3 in
2	Height – Front Axle Center	858 mm	33.8 in
3	Length – Between Tandem Axles	2285 mm	90 in
4	Length – Front Axle to Moldboard	4048 mm	159.4 in
5	Length – Front Axle to Mid Tandem	10 278 mm	404.6 in
6	Length – Front Tire to End of Rear Frame	14 194 mm	558.8 in
7	Length – Counterweight to Ripper	16 102 mm	633.9 in
8	Ground Clearance at Rear Axle	607 mm	23.9 in
9	Height to Top of Cylinders	3846 mm	151.4 in
10	Height to Exhaust Stack	4322 mm	170.2 in
11	Width – Tire Center Lines	3450 mm	135.8 in
12	Width – Outside Rear Tires	4225 mm	166.3 in
13	Width – Outside Front Tires	4280 mm	168.5 in

Standard Equipment

Standard equipment may vary. Consult your Cat dealer for details.

POWER TRAIN

- Air cleaner, dual stage dry type radial seal with service indicator and automatic dust ejector
- Air-to-air after cooler (ATAAC)
- Brakes, oil disc, four-wheel
- Demand fan, hydraulic
- Differential, lock/unlock, Automatic/Manual
- Drain, engine oil, high speed
- Electronic over speed protection
- Engine, C18 with ACERT Technology, diesel, with automatic engine derate and idle control, and compression brake
 - C18 ACERT (Tier 3 for use in Lane 3 only EPA/ARB Tier 4 Interim AB&T Certified Engine Tier 3, credit using engine)
 - C18 ACERT (non-regulated) Provides improved performance in regions using fuel with high sulfur content; improved altitude capability, fuel economy, and resistance to piston deposits. For use only in non-regulated markets. **NOT FOR USE BY:** United States, Canada, Guam, Samoa, Croatia, Turkey, European Union, Russia Saudi Arabia, UAE, South Africa, Israel, China, India, Japan, Singapore and South Korea
- Note: For U.S. dealers only, EPA/ARB Tier 4 Interim AB&T Certified Engine (Tier 3, credit using engine)
- Note: For Canadian dealers only, engine is certified to Environment Canada Tier 3 standards
- Note: For all other regions, engine meets non-current U.S. EPA Tier 3 or EU Stage IIIA emission standards
- Note: For all non-regulated regions, engines suitable for regions not subjected to any emission regulations
- Ether starting aid
- Parking brake, multi-disc, sealed and oil cooled
- Sediment drain, fuel tank
- Transmission, 6 speed forward and 3 speed reverse, power shift, autoshift

ELECTRICAL

- Alarm, back-up
- Alternator, 150 ampere, sealed, filtered air intake
- Batteries, maintenance free, 1,500 CCA
- Electrical hydraulic valves, base 8
- Electrical system, 24 volt
- Grade Control Ready (cab harness, software, electrical hydraulic valves, bosses and brackets)
- Lights, reversing, stop, tail, turn
- Starter, receptacle, plug-in

OPERATOR ENVIRONMENT

- Air conditioner and heater
- Articulation, automatic return to center
- Defroster fan, rear window
- Display, digital speed and gear
- Gauges (analog) inside the cab (fuel, articulation, engine coolant temp, engine RPM and system voltage)

- Messenger operator information system
- Mirror, inside rearview, wide angle
- Power port, 12V
- Radio ready (entertainment)
- ROPS cab, sound suppressed less than 75 dB(A) ISO 6394 100% fan speed
- Seat, cloth, air suspension
- Throttle control, electronic
- Windows: laminated glass – fixed front with intermittent wiper, sides (2), rear with wiper/washer

TECHNOLOGY PRODUCTS

- Product Link Ready

SAFETY AND SECURITY

- Clutch, circle drive slip
- Doors, 8 engine compartment, (four left-hand, four right-hand) locking
- Ground level engine shutdown
- Horn, electric
- Lockout, hydraulic implement for roading and servicing
- Paint, glare reducing, top of front frame and top of rear enclosure
- Seat belt, retractable 76 mm (3 in)
- Secondary steering
- Tandem walkway/guards

TIRES, RIMS, AND WHEELS

- 25 × 29 multi-piece rims

GROUND ENGAGING TOOLS

- Cutting edges, 330 mm × 28 mm (13 in × 1 1/8 in), curved DH-2 steel, 25 mm (1 in), mounting bolts, 19 mm (0.75 in), includes endbits
- Moldboard, 7315 mm × 1067 mm × 50 mm (24 ft × 42 in × 2 in)
- Ripper, rear, 7 shank capacity, 3 shanks/tips provided

FLUIDS

- Extended Life Coolant to –50° C (–58° F)
- Fluid check, ground level

OTHER STANDARD EQUIPMENT

- Accumulators, blade lift
- Autolube, Lincoln Centro-Matic
- Drawbar, 8 shoe with replaceable wear strips
- Electrical hydraulic valves, base 8
- Fuel tank, 1325 L (350 gal) Fast Fill
- Ground level fueling
- Push plate-counterweight
- S·O·SSM ports, engine, hydraulic, transmission, coolant, fuel

Optional Equipment

Optional equipment may vary. Consult your Cat dealer for details.

	kg	lb		kg	lb
GROUND ENGAGING TOOLS			LIGHTING PACKAGES		
• Cutting edge, 330 mm × 28 mm (13 in × 1.12 in) straight cutting edge	—	—	• Lighting package, basic (halogen)	17	38
• Cutting edge, 330 mm × 45 mm (13 in × 1.77 in) straight cutting edge	363	800	• Lighting package, plus (HID)	48	106
• Cutting edge, 406 mm × 28 mm (16 in × 1.12 in) straight cutting edge	181	400	• Lights, work, heel 5×5	5	10
• Cutting edge, 406 mm × 45 mm (16 in × 1.77 in) straight cutting edge	589	1,300	• Lights, work, heel HID	15	32
• Tooth, ripper, straight shank, one tooth	51	158	• Light, LED warning strobe	2	5
HYDRAULICS			OPERATOR ENVIRONMENT		
• Control, blade, variable float	91	200	• Radio, 12V, AM/FM weather band	2	5
OPERATOR ACCESS			• Radio, satellite, Sirius	2	5
• Dual access platform package, basic	639	1,410	• Radio ready, satellite	2	5
• Dual access platform package, plus	651	1,436	• Camera, rear vision	9	20
• Cab basic	26	57	• Mirrors, outside mounted	13	28
• Cab plus	26	57	• Mirrors, outside heated 24V	14	30
TECHNOLOGY PRODUCTS			GUARDS		
• Product Link	5	10	• Guard package	249	550
• Installation, AccuGrade Ready	18	40	• Guard, sound	204	450
OTHER ATTACHMENTS			• Sound suppression, engine enclosure	28	62
• Fenders, rear	574	1,265			
• Rim, spare 29.5-29	363	800			
• Cold weather package	—	—			

24M Motor Grader

For more complete information on Cat products, dealer services, and industry solutions, visit us on the web at www.cat.com

© 2012 Caterpillar Inc.
All rights reserved

Materials and specifications are subject to change without notice. Featured machines in photos may include additional equipment. See your Cat dealer for available options.

CAT, CATERPILLAR, SAFETY.CAT.COM, their respective logos, "Caterpillar Yellow" and the "Power Edge" trade dress, as well as corporate and product identity used herein, are trademarks of Caterpillar and may not be used without permission.

AEHQ6771 (07-2012)

