



Machines

ASC Single Drum Rollers 7 – 25 t

www.ammann-group.com



Powerful, Efficient, Safe

Outstanding safety, best compaction outputs and up-to-date design ensure highest efficiency and best results under hardest working conditions. Best quality of compaction with minimum number of passes brings more profit to the enduser.

Operator's comfort and safety

- State of the art design, perfect visibility ensured (1 m x 1 m)
- Roomy, ergonomic cabin, ventilated and heated (platform version available)
- Accessibility of cab from both sides
- ROPS/FOPS protection of cabin and platform version
- All maintenance points easy accessible for safe and efficient service
- Simple and clearly laid out operating instruments

Minimum operating costs

- Minimum number of passes to reach compaction targets
- Reliable engine with minimum fuel consumption
- Anti-corrosive protection of fuel tank – no big fuel filter needed
- Concept endurance and lifetime for longtime satisfaction

Highest efficiency and reliability

- High performance vibration system, best values of static and dynamic loads, effective amplitudes
- Hydrostatic powertrain without rear axle for max. traction and stability
- Articulation joint with high capacity cross rolling bearing
- ACE system for measuring and automatic regulation of compaction parameters (option)

Highest working output

- Balanced drum for uniform compaction effect
- Highest values of the centrifugal forces and amplitudes
- Maximal depth effect



Different Versions for all needs

- D Standard version for compaction applications with a smooth drum.
- PD Padded drum rollers are designed for medium- and large-scale compaction of semi-cohesive and cohesive materials. Available for all models.

- HD Heavy duty version for better traction abilities in heavy terrain – ATC system (interwheel, interaxle differential control), tyre ballast, tractor tyres and HD power drive.
- HT High traction version for long time operation on slopes and landfills. ATC system, tyre ballast, tractor tyres and HT power drive.

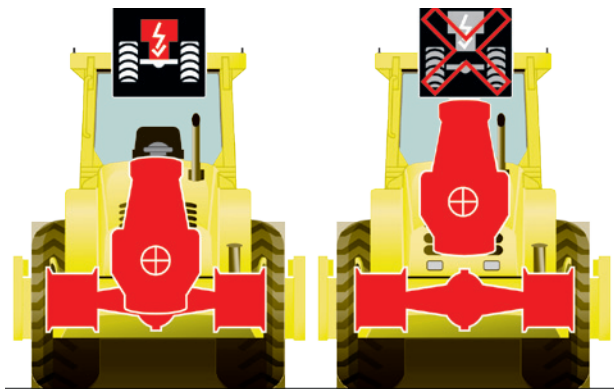

ASC concept uses three Hydromotors for drum and independent rear wheel drive. This “no axle” solution allows very low emplacement of the engine, shortening wheelbase and covered contour of the machine.

Benefits are significant. Very low centre of gravity giving to ASC rollers outstanding stability in extreme terrains. Short wheelbase provides very small turning radius and best maneuverability. Compact design and contour ensured best visibility from cab onto working field and rear of the machine.

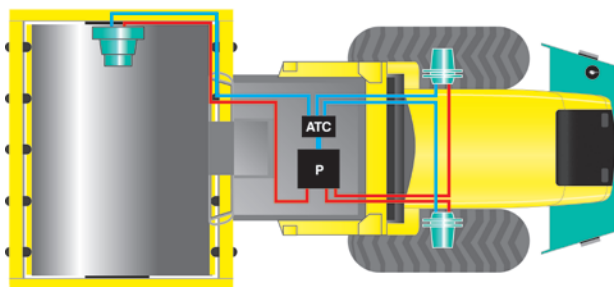

Blue = D-Version
 Blue + Red = ATC-Version



Accessible engine compartment and battery location

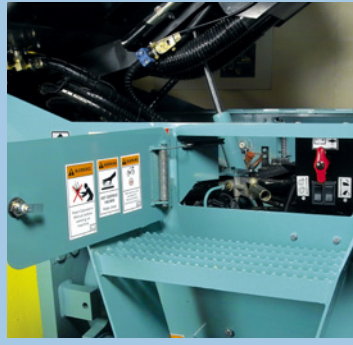

Tilting cabin for safe and easy maintenance and service

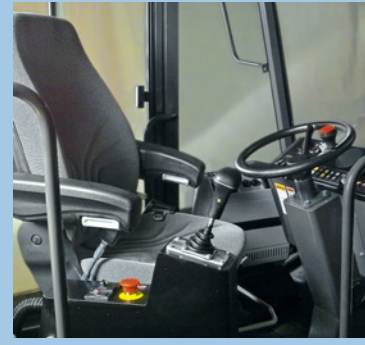

Integrated cockpit with rotating seat

Efficient compaction

Pre-selected working speeds provide optimum impact spacing for efficient compaction process.

Max. compaction results

Front frame and drum of the machine are optimally balanced. This feature keeps uniform compaction effect on the whole working width and increases compaction result.

Articulation joints

Double bearing articulation and oscillating joint.

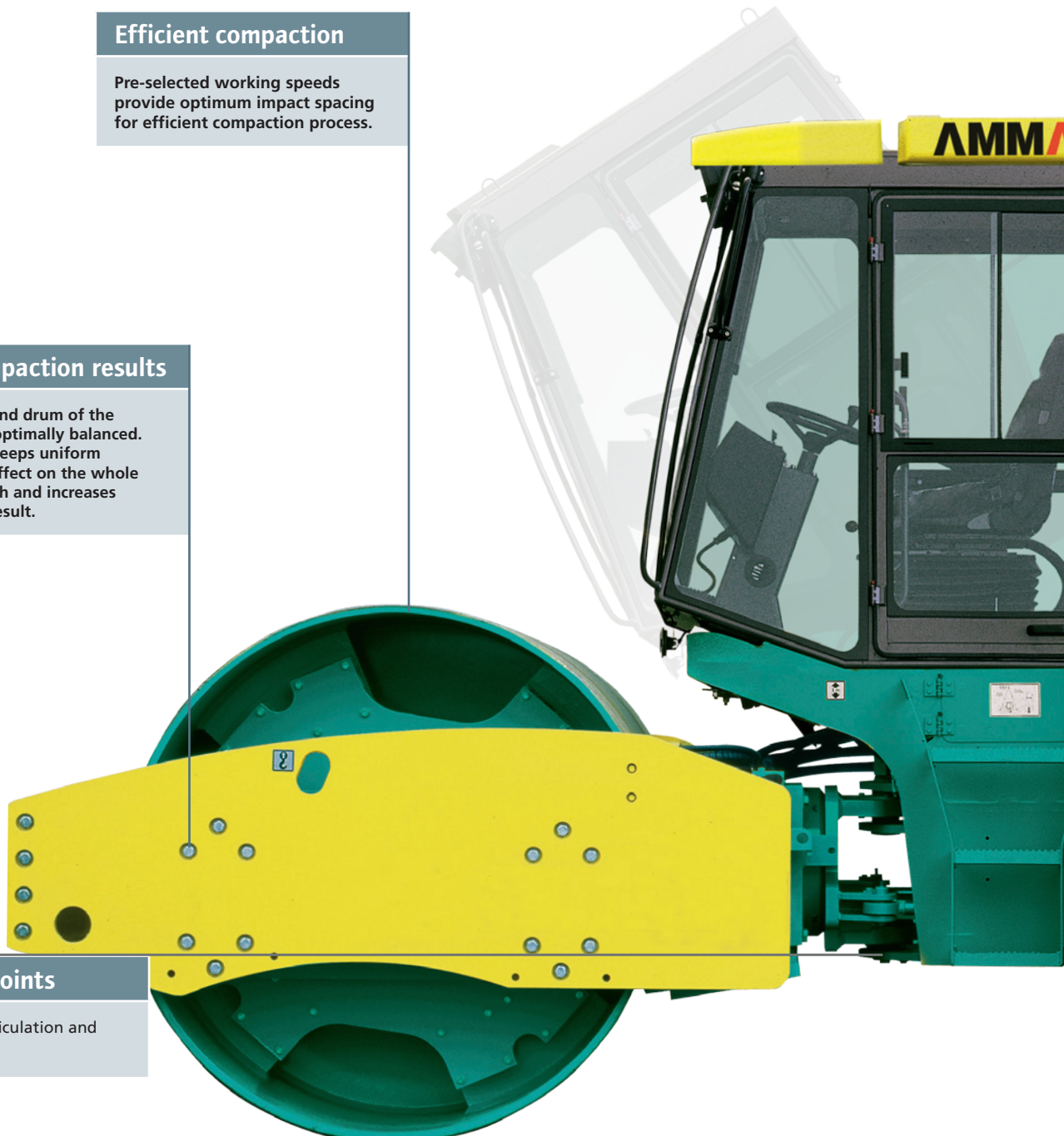

ASC Single Drum Rollers

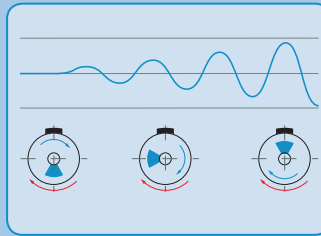
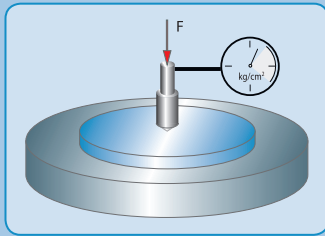

Optional equipment

ACE – Ammann Compaction Expert is the unique electronic measuring and controlling system for vibrating rollers. It automatically adjusts amplitudes and frequencies to suit the characteristic of the ground; optional printing device and GPS for Continuous Compaction Control (CCC).



Accessibility
Electrohydraulic cabine and engine hood tilt for easiest and safest access of all maintenance and service.

Long working intervalls
The large fuel tank (from 275 lt. of 7-tonner up to 405 lt. of 25-tonner) is able to extend working intervalls up to 32 hours.

Hydrostatic drive
ASC machines are given great operational opportunities through Ammann's original concept of all wheel hydrostatic drive. Very low center of gravity ensures an outstanding stability of the machine in the heaviest terrain.



Technical Specifications

	Type	ASC 70 D	ASC 90 D	ASC 110 D	ASC 130 D	ASC 150 D	ASC 200 D	ASC 250 D
Weights								
Operating weight max	kg	9325	10585	15400	16535	18285	25780	29205
Operating weight CECE	kg	7140	8820	11495	12630	14380	20750	25330
Static linear load	kg/cm	23,9 / 24,3	31,6 / 32,0	32,4 / 32,6	36,8 / 36,7	46,4 / 46,5	63,2 / 63,2	78,4 / 78,4
Front axle load	kg	4020 / 4080	5315 / 5375	7130 / 7165	8035 / 8075	10200 / 10235	14150 / 14150	17570 / 17570
Rear axle load	kg	3120 / 3540	3505 / 3505	4365 / 5565	4365 / 5565	4180 / 5380	6555 / 7755	7760 / 7760
Drum and wheels								
Working width	mm	1680	1680	2200	2200	2200	2240	2240
Drum diameter	mm	1300	1300	1500	1500	1500	1700	1700
Shell thickness	mm	25	25	25	35	40	45	50
Tires	-	Mitas 14,9 - 24	Mitas 14,9 - 24	Mitas 23,1 - 26	Mitas 23,1 - 26	Mitas 23,1 - 26	Mitas 23,5 - 25	Mitas 23,5 - 25
	Type	ASC 70 PD	ASC 90 PD	ASC 110 PD	ASC 130 PD	ASC 150 PD	ASC 200 PD	ASC 250 PD
Weights								
Operating weight max.	kg	8180	9440	14150	14955	16515	25850	29390
Operating weight CECE	kg	7058	8765	11925	12730	14290	20775	25515
Front axle load	kg	4020 / 4025	5260 / 5320	7560 / 7795	8125 / 8165	10110 / 10145	14220 / 14220	17755 / 17755
Rear axle load	kg	3120 / 3540	3505 / 3505	4365 / 5565	4365 / 5565	4180 / 5380	6555 / 7755	7760 / 7760
Drum and wheels								
Working width	mm	1680	1680	2200	2200	2200	2240	2240
Drum diameter	mm	1240	1240	1440	1440	1440	1600	1600
Shell thickness	mm	15	15	20	25	28	30	30
No. of pads	-	104	104	140	140	140	150	150
Contact area per pad foot	cm ²	114	114	120	120	120	143	145
Height of pad	mm	80	80	100	100	100	120	154
Tires	-	Mitas 14,9 - 24	Mitas 14,9 - 24	Mitas 23,1 - 26	Mitas 23,1 - 26	Mitas 23,1 - 26	Mitas 23,5 - 25	Mitas 23,5 - 25
Engine								
Engine make	-	Cummins	Cummins	Cummins	Cummins	Cummins	Cummins	Cummins
Type	-	QSB 3.3-C99 Tier III		QSB 4.5- C160 Tier III		QSB 6,7 - C 220 Tier III		
Rated power DIN 6271	kW/HP	74 / 99	74 / 99	119 / 160	119 / 160	119 / 160	164 / 220	164 / 220
Drive								
No. of travel speed	-	4	4	4	4	4	4	4
Max. speed	km/h	12	11	10,6	10,6	10	10,5	10
Max. speed - HD/HT	km/h	10 / 8,4	10,3 / 8,5	8,7 / 8	8,7 / 8	8,1 / 7	9,1 / 7,5	8,6 / 8,7
Gradeability with vib.	%	45	45	45	45	45	50	45
Gradeability - HD/HT	%	55 / 60	50 / 55	55 / 60	55 / 60	55 / 60	55 / 60	55 / 60
Steering								
Turning radius inside	mm	3090	3090	3050	3050	3050	3900	3900
Steering and oscillating angle	+ / - °	36 / 12	36 / 12	36 / 10	36 / 10	36 / 10	36 / 10	36 / 10
Vibration								
Amplitudes	mm	1,7 / 0,86	1,85 / 0,96	1,85 / 1,15	1,9 / 1	2,0 / 1,0	2,0 / 1,0	2,2 / 1,1
Frequencies	Hz	30 / 40	30 / 40	32 / 35	30 / 36	29 / 35	28 / 34	28 / 34
Centrifugal force	kN	145 / 130	160 / 145	277 / 206	300 / 200	325 / 237	400 / 300	460 / 340
Capacities								
Fuel	l	275	275	410	410	410	405	405

Dimensions in mm	A	D	D1	G	G1	H	H1	L	T	W	W1	W2
ASC 70 D	2560	1300		385	375	2870	2200	5195	25	1680	1880	95
ASC 70 PD	2560	1240	1400	385	375	2870	2200	5195	15	1680	1880	95
ASC 90 D	2560	1300		385	375	2870	2200	5195	25	1680	1930	120
ASC 90 PD	2560	1240	1400	385	375	2870	2200	5195	15	1680	1930	120
ASC 110 D	2820	1500		420	430	3030	2375	5686	25	2200	2436	118
ASC 110 PD	2820	1440	1640	420	430	3030	2375	5686	20	2200	2436	118
ASC 130 D	2820	1500		420	430	3030	2375	5686	35	2200	2436	118
ASC 130 PD	2820	1440	1640	420	430	3030	2375	5686	25	2200	2436	118
ASC 150 D	2820	1500		420	430	3030	2375	5686	40	2200	2500	142
ASC 150 PD	2820	1440	1640	420	430	3030	2375	5686	28	2200	2500	142
ASC 200 D	3160	1700		500	430	3265	2560	6300	45	2240	2500	120
ASC 200 PD	3160	1600	1840	500	430	3265	2560	6300	30	2240	2500	120
ASC 250 D	3290	1700		500	430	3265	2560	6560	50	2240	2500	120
ASC 250 PD	3290	1600	1908	500	430	3265	2560	6560	30	2240	2500	120

Dimensions of the HD and HT versions are identical.

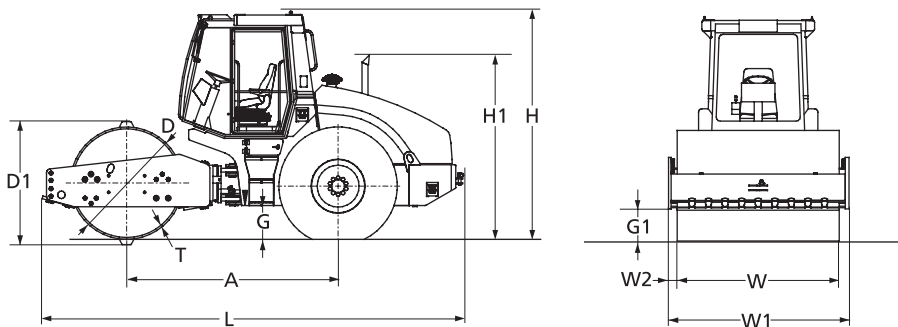

PD shell kit



Dozer blade



Platform version

Standard

- CE conformity - ROPS, TIER III, seat switch, noise reduction kit
- 2 mode vibratory system
- Working lights
- Cabin vented, heated
- Hydraulic testports
- Inter-wheel diff. lock
- Steel scrapers
- Manual tilting of hood/cab
- Murphy multifunction display

Special application kits

- ATC -Ammann Traction Control: Interaxle diff. lock
- PD shell kit
- Dozer blade
- Tyres ballast filling Working
- Vulcolan scrapers
- Engine pre-filter
- Padlock device for fuel tank inlet

Compaction control and special

- ACE Ammann Compaction Expert with ADS and printer
- ADC Ammann Digital Compactometer
- ACEplus – ccc through ACEplus GPS

Optional items

Operators platform and cabin

- Open platform w. guarding rails and sun roof
- Air conditioning
- Radio preparation with antenna
- Radio CD
- Electrohydraulic cabin and hood tilting

Safety

- Warning beacon
- Back-up alarm, fan
- Alternator safety screen
- Road lighting

Other

- Biological degradable hydr. oil (Panolin)
- Tools kit
- First service kit
- Fire extinguisher (Minimax)
- First aid package
- Special color/design of machine

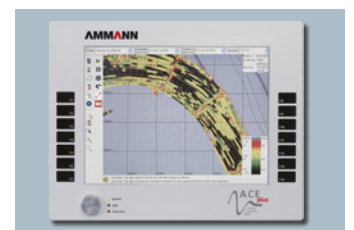

ACEplus



ADC

Amman distribution companies:

Germany:

Ammann Verdichtung GmbH
D-53773 Hennef
Tel +49 22 42 880 20
Fax +49 22 42 88 02 59
ammann@ammann-hennef.de

RAMMAX Maschinenbau GmbH

D-72555 Metzingen
Tel +49 71 23 922 30
Fax +49 71 23 92 23 50
rammax@ammann-group.com

France:

Ammann France SA
F-94046 Créteil/Cedex
Tel +33 1 45 17 08 88
Fax +33 1 45 17 08 90
contact@ammann.fr

United Kingdom:

Ammann Equipment Ltd.
Bearley Stratford-upon-Avon
GB-Warwickshire, CV37 OTY
Tel +44 1789 414 525
Fax +44 1789 414 495
sales@ammann.co.uk

USA:

Ammann America Inc.
Ponte Vedra, Florida 32082, USA
Tel +1 904 543 1691
Fax +1 904 543 1781
info@ammann-america.com

Poland:

Ammann Polska sp.zo.o.
02-230 Warszawa
Tel +48 22 33 77 900
Fax +48 22 33 77 929
ammann@ammann.com.pl

Ammann manufacturing
companies:

Switzerland:

Ammann Schweiz AG
CH-4901 Langenthal
Tel +41 62 916 63 56
Fax +41 62 916 64 03
info@ammann-group.com

Germany:

Ammann Verdichtung GmbH
D-53773 Hennef
Tel +49 22 42 880 20
Fax +49 22 42 88 02 59
ammann@ammann-hennef.de

RAMMAX Maschinenbau GmbH

D-72555 Metzingen
Tel +49 71 23 922 30
Fax +49 71 23 92 23 50
rammax@ammann-group.com

Czech Republic:

Ammann Czech Republic a.s.
CZ-54901 Nové Město nad Metují
Tel +420 491 476 111
Fax +420 491 470 405
info@ammann-group.cz

