



# 445 EXL

## Featuring...

- ❑ 260 HP Cummins QSC engine
- ❑ Auto reversing cooling fan
- ❑ Individual operator settings for smooth functions
- ❑ System self diagnostics and troubleshooting features
- ❑ 540° upper turntable rotation
- ❑ Purpose built forestry carbody with high ground clearance and independent closed loop hydrostatic drive.

*The EX-Series machines are the perfect evolutionary blend of the legendary Timbco concept and advanced Valmet technologies. The next generation machines integrate total electronic control into an easy-to-use operator interface providing smoother performance, better productivity and improved fuel economy for both feller-buncher and harvester applications.*

 **Timbco**



**Komatsu Forest LLC**  
1075 Airport Road, P.O. Box 516  
Shawano, WI 54166 - USA  
Telephone 1-715-524-2820  
Fax 1-715-526-2347  
[www.komatsuforest.com](http://www.komatsuforest.com)

# 445 EXL

# Technical Specifications

Komatsu Forest LLC reserves the right to change specifications without notice or obligation. Products illustrated may be equipped with non-standard equipment. Other manufacturer's equipment or attachments shown are used for illustration purposes only. Komatsu Forest LLC does not warrant the safety, reliability or operation of other manufacturer's equipment or attachments.

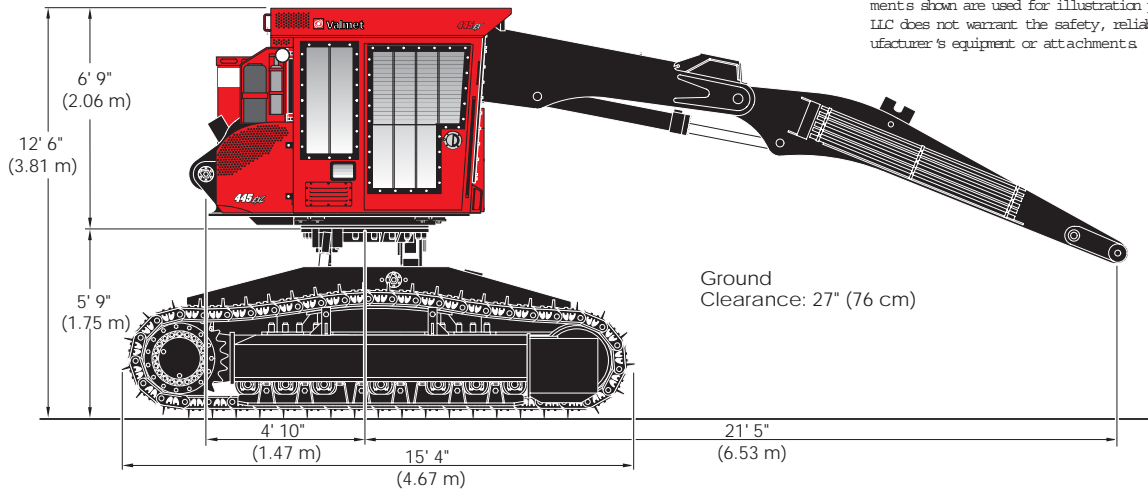

## Engine

Cummins QSC	260 HP (194 KW)
Torque	870 ft.- lbs. (1179 Nm) @ 1200 RPM
Fuel capacity	180 gal. (681 litre)

## Machine Width

STD 600 mm single grouser	10'4" (3,15 m)
OPT 700 mm single grouser	10'8" (3,25 m)
OPT 700 mm double grouser	10'8" (3,25 m)
OPT 900 mm triple grouser	11'4" (3,45 m)

## Machine Weight

Base machine	60,980 lb. (28 408 kg)
--------------	------------------------

Approximate "woods ready" operating weight without attachment, fully serviced including 1/2 tank fuel 90 gal. (189 litres) at 738 lb. (335 kg) and 175 lb. (80 kg) operator.

## Ground Pressure

STD 600 mm single grouser	8.65 psi
OPT 700 mm single grouser	7.45 psi
OPT 700 mm double grouser	7.45 psi
OPT 900 mm triple grouser	5.85 psi

## Cab Leveling

Front	27° (51%)
Rear	7° (12%)
Side	20° (36%)

## Cutting Area (std length boom, to attachment pin)

Maximum	21'5" (6,53 m)
Minimum	7'6" (2,29 m)
Swath	13'11" (4,24 m)

## Lifting Capacity (without attachment)

@ 10' (3,05 m)	24,250 lb. (11 000 kg)
@ 15' (4,57 m)	18,200 lb. (8 255 kg)
@ 20' (6,10 m)	11,500 lb. (5 216 kg)

## Track System

Caterpillar 330 D7 with 600 mm SG track shoes, greased chain assembly, Lohmann GFT80 final drive, Rexroth auto-shift track motors.

Tractive effort	78,145 lb. (35 446 kg)
Effort to weight ratio	1.28:1
Speed	(0-3.3 mph (0-5,3 km/h))

## Hydraulics

Implement circuits feature IQAN digital control system with Rexroth 145 cc 86 gpm (325 litre) pump and Parker K220/L90 9-section main control valve. Dual track drives feature closed loop hydrostatic circuits with separate Rexroth 55gpm (208 litre) pumps. Independent horsepower control for track drive and implement systems.

## Swing

Swing torque, standard motor	47,100 ft-lbs
------------------------------	---------------

## Booms

Box construction with 3" (76 mm) minimum diameter pins and Timbco's legendary setback boom geometry. Main to stick knuckle joint 3 1/2" pin.

## Operator's Cab

ROPS/FOPS/OPS certified, low noise excellent

visibility, and 3 emergency escape routes. Other features include a Red Dot A/C and heater, AM/FM radio with cassette, and halogen lighting.

## Machine Control System

- Engine management
  - Electronic interface between machine function & engine
  - anti-engine stall independent for track and implement systems
- Operator push button interface
  - Function speed
  - Function smoothness
  - 4 operator mode settings
  - Multiple languages
- System self-diagnostics
- Troubleshooting features
  - On board multi-meter with graphics error logging events
- Machine protection
  - Over temperature and under temperature conditions results in reduced machine output
  - System records all at-limit events

## Optional Equipment

- Track shoe widths (Contact Dealer)
- 4 boom options (Contact Dealer)
- SisuDiesel 260 HP (194 KW) or 300 HP (224 kW)
- Komatsu QSC 300HP (224 kW)
- High swing torque option 58,400 ft-lbs
- Fire suppression system
- 1-1/4" (32 mm) front window
- Xenon high intensity lighting
- Engine and cab accessories
- Hydraulic pump, valve, and line options



**Komatsu Forest, LLC**  
 1075 Airport Road, P.O. Box 516, Shawano, WI 54166 - USA  
 Telephone 1-715-524-2820, Fax 1-715-526-2347, www.komatsuforest.com

