

PK 100002

PALFINGER

LIFETIME EXCELLENCE

**WITH HPSC AND POWER LINK PLUS
OPERATIONS ARE POSSIBLE EVEN IN
RESTRICTED SPACES**



LIFETIME EXCELLENCE

PALFINGER LOADER CRANES ARE OUTSTANDING WITH THEIR SUPERIOR LIFE-CYCLE PERFORMANCE. THEY ARE THE MOST ECONOMICAL AND ALSO THE MOST RELIABLE OVER THE ENTIRE PRODUCT LIFE. FROM SOLUTION FINDING TO RESALE.

BETTER
SOLUTIONS

BETTER
EFFICIENCY

BETTER
ERGONOMICS

HIGHER VALUE
RETENTION



HIGHER
AVAILABILITY

HIGHER
SERVICEABILITY

BETTER
ECOLOGY

MORE
RELIABILITY

For further information please visit: www.palfinger.com/thebrand



ENORMOUS OUTREACH AND PRECISION





- More lifting power due to E-HPLS
- Additional applications due to Power Link Plus
- More efficient and faster due to continuous slewing system
- Shorter loadcycles due to high speed extension
- Maximum reliability due to PAL 50



FIRST-RATE IN DESIGN AND PERFORMANCE

12

HIGHLIGHTS

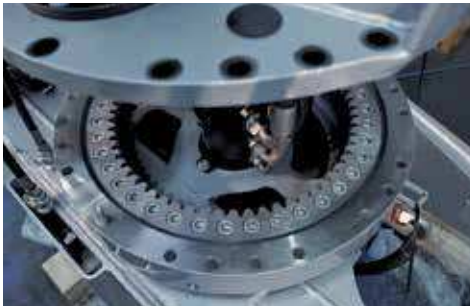

CONTINUOUS SLEWING SYSTEM
UNRESTRICTED MOVEMENT

More efficient in operation due to faster loading cycles, since the crane can be slewed over a shorter distance. The crane works more efficiently and faster.



POWER LINK PLUS
HIGH VARIETY OF USES

With the 10-degree reverse linkage system, you can reach through low door openings and also work inside buildings. Heavy crane work – even in difficult conditions.



HIGH SPEED EXTENSION
FOR EFFICIENT ASSIGNMENTS

The High Speed Extension speeds up the extension boom system. Crane works faster and more efficiently.

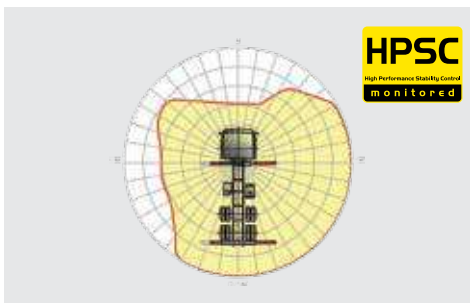

HPSC
MAXIMUM UTILISATION OF THE WORKING RANGE

The variable stabiliser positioning of the High Performance Stability Control System makes it possible to utilise the lifting capacity to the maximum. It enables working within tight spaces.



PAL 50
COMFORT AND SAFETY

The PALTRONIC 50, PALFINGER offers the latest control electronics for the series production crane. The custom designed electronic operates and monitors the crane and offers more efficiency in use and safety.



E-HPLS
INCREASED LIFTING CAPACITY

The manually activated E-HPLS increases the capacity of the crane up to 10% while the operating speed is reduced. The crane operates more efficiently.



ROPE WINCH
ADDITIONAL APPLICATIONS

Greatest possible attention was paid to the operator-friendliness and efficiency in use thanks to the high lifting capacity, speed and optimum winding performance.



INTERGAL BASE FRAME
PERFECT INTEGRATION

A Torsion resistant construction is possible due to an integral base frame. The low overall installation height and the weight savings allow for more efficiency in use.



RADIO REMOTE CONTROL
DIALOGUE WITH THE OPERATOR

PALFINGER radio remote controls are equipped with linear lever or cross lever and provide the greatest possible comfort for the operator. All EH models with LED-Display inform the crane operator about the different operating conditions.



HOSE EQUIPMENT FOR ATTACHMENTS
VERSATILE AND USER-FRIENDLY

The hose equipment offers an easy means of connecting auxiliary equipment. The hose equipment is guided in hose trays for protection.

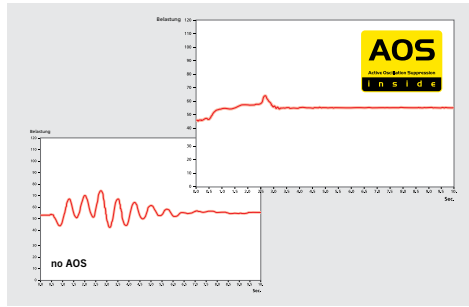

AOS
MAXIMUM PRECISION AND SAFETY

The active oscillation suppression system prevents "post-oscillation" in the event of rapid braking or load changes. The stress peaks on the extension boom system are reduced and material fatigue and wear are minimised. This increases the resale value.



FLY-JIB
ADDITIONAL WORKING RANGE

A fly-jib system extends the working range of the crane and increases the possible areas of application. More efficiency in use thanks to the improvement of the movement geometry of the crane.



* Optional features / country-specific equipment

PK 100002 PERFORMANCE

C

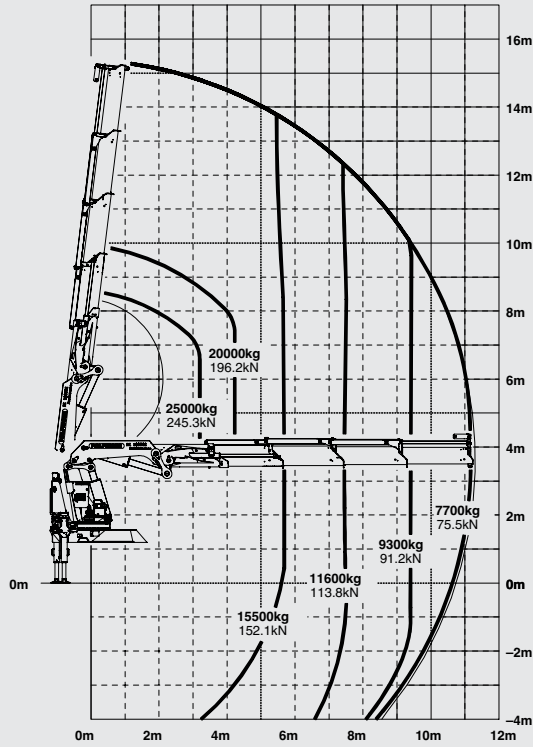

E

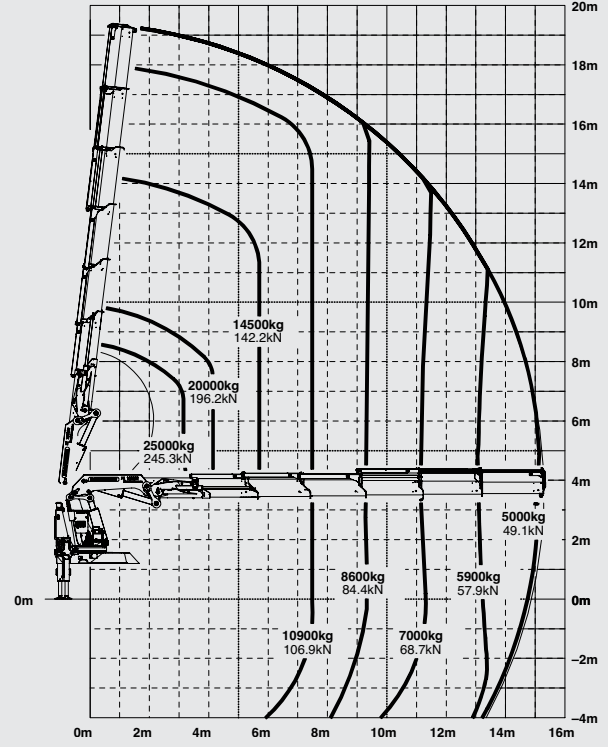

F

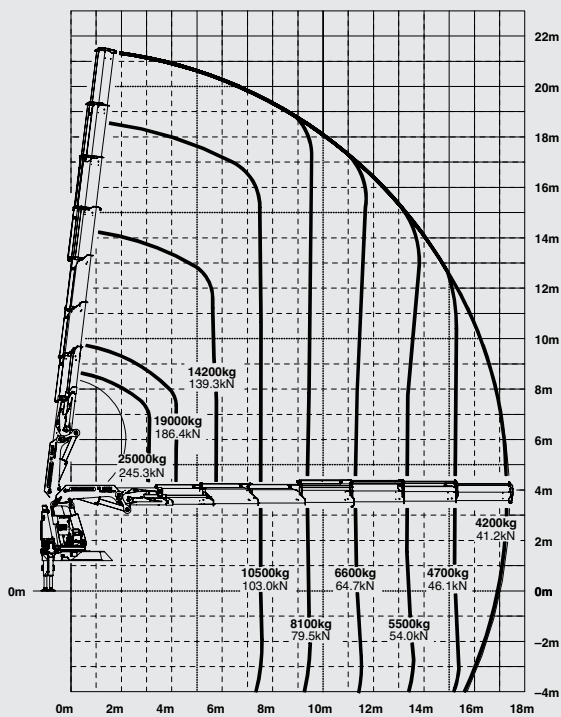

H

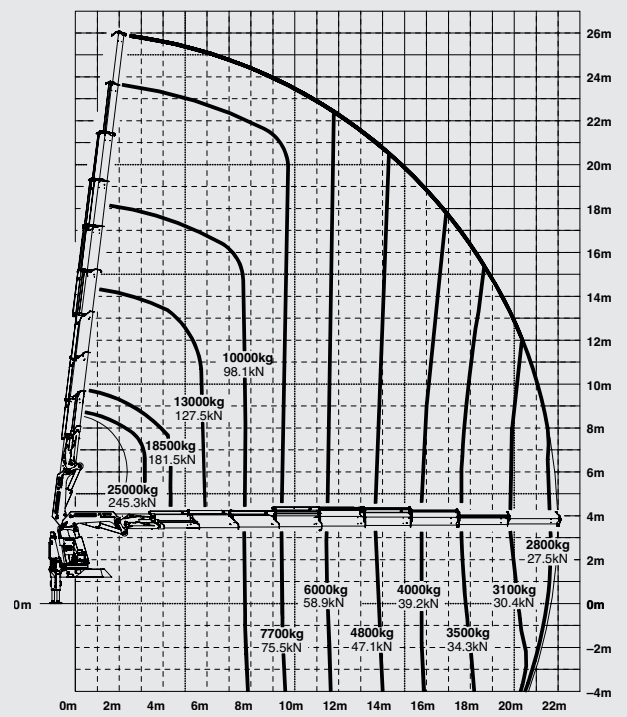

RELIABLE IN EVERY SITUATION

G PJ125E JV1

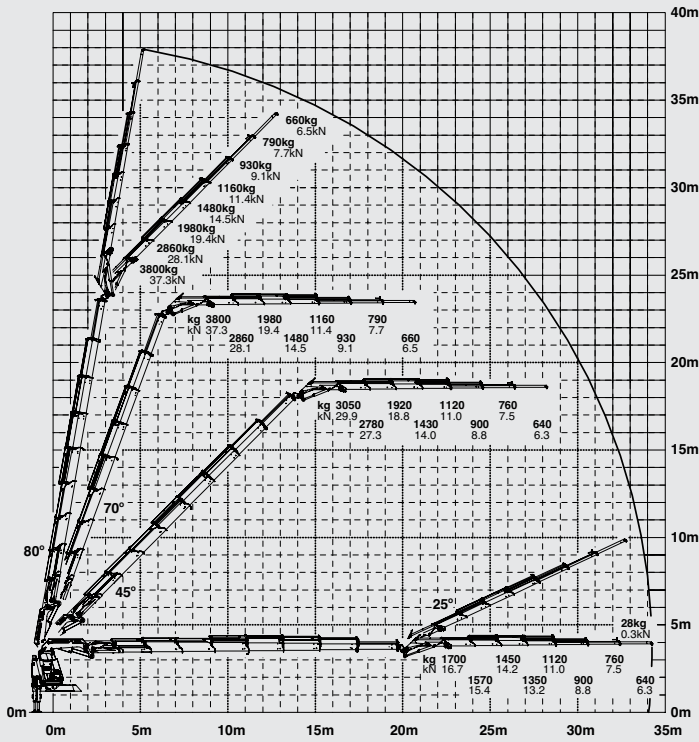

F PJ170 JV1

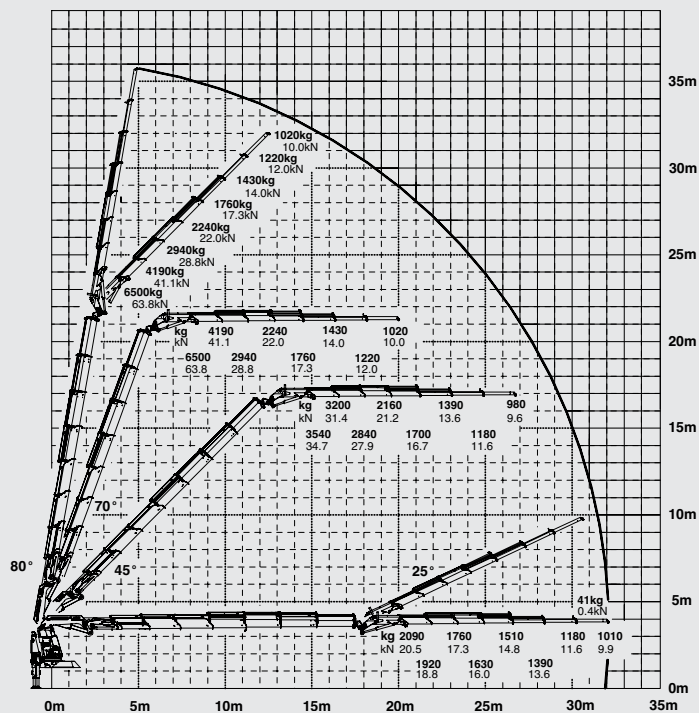

LIFTING CAPACITIES

B	max.	30000 kg	66140 lbs
4.4 m	14' 5"	19900 kg	43870 lbs
5.6 m	18' 4"	15700 kg	34610 lbs
7.4 m	24' 3"	12000 kg	26450 lbs
9.2 m	30' 2"	9700 kg	21380 lbs

C	max.	30000 kg	66140 lbs
4.4 m	14' 5"	19640 kg	43300 lbs
5.6 m	18' 4"	15400 kg	33950 lbs
7.4 m	24' 3"	11640 kg	25660 lbs
9.2 m	30' 2"	9320 kg	20550 lbs
11.1 m	36' 5"	7720 kg	17020 lbs

D	max.	30000 kg	66140 lbs
4.4 m	14' 5"	19300 kg	42550 lbs
5.6 m	18' 4"	15100 kg	33290 lbs
7.4 m	24' 3"	11300 kg	24910 lbs
9.2 m	30' 2"	8960 kg	19750 lbs
11.1 m	36' 5"	7370 kg	16250 lbs
13.1 m	43' 0"	6230 kg	13730 lbs

E	max.	30000 kg	66140 lbs
4.4 m	14' 5"	19000 kg	41890 lbs
5.6 m	18' 4"	14800 kg	32630 lbs
7.4 m	24' 3"	10960 kg	24160 lbs
9.2 m	30' 2"	8630 kg	19030 lbs
11.1 m	36' 5"	7020 kg	15480 lbs
13.1 m	43' 0"	5870 kg	12940 lbs
15.2 m	49' 10"	5050 kg	11130 lbs

F	max.	30000 kg	66140 lbs
4.4 m	14' 5"	18800 kg	41450 lbs
5.6 m	18' 4"	14530 kg	32030 lbs
7.4 m	24' 3"	10670 kg	23520 lbs
9.2 m	30' 2"	8300 kg	18300 lbs
11.1 m	36' 5"	6700 kg	14770 lbs
13.1 m	43' 0"	5540 kg	12210 lbs
15.2 m	49' 10"	4700 kg	10360 lbs
17.3 m	56' 9"	4120 kg	9080 lbs
19.5 m*	64' 0"	3500 kg	7720 lbs
21.8 m*	71' 6"	3000 kg	6610 lbs

G	max.	30000 kg	66140 lbs
4.4 m	14' 5"	18620 kg	41050 lbs
5.6 m	18' 4"	14330 kg	31590 lbs
7.4 m	24' 3"	10430 kg	22990 lbs
9.2 m	30' 2"	7960 kg	17550 lbs
11.1 m	36' 5"	6360 kg	14020 lbs
13.1 m	42' 12"	5220 kg	11510 lbs
15.2 m	49' 10"	4420 kg	9740 lbs
17.3 m	56' 9"	3820 kg	8420 lbs
19.6 m	64' 4"	3350 kg	7390 lbs
21.7 m*	64' 0"	2880 kg	6350 lbs
24.8 m*	81' 4"	2480 kg	5470 lbs

H	max.	29200 kg	64370
4.4 m	14' 5"	18500 kg	40780 lbs
5.6 m	18' 4"	14150 kg	31190 lbs
7.4 m	24' 3"	10200 kg	22490 lbs
9.2 m	30' 2"	7850 kg	17310 lbs
11.1 m	36' 5"	6200 kg	13670 lbs
13.1 m	42' 12"	5030 kg	11090 lbs
15.2 m	49' 10"	4200 kg	9260 lbs
17.3 m	56' 9"	3580 kg	7890 lbs
19.6 m	64' 4"	3100 kg	6830 lbs
21.9 m	71' 10"	2770 kg	6110 lbs
24.3 m*	79' 9"	2400 kg	5290 lbs
26.9 m*	88' 3"	1650 kg	3640 lbs

*mechanical extension

PERFECT DIMENSIONS

EXTENSION BOOM VARIATIONS

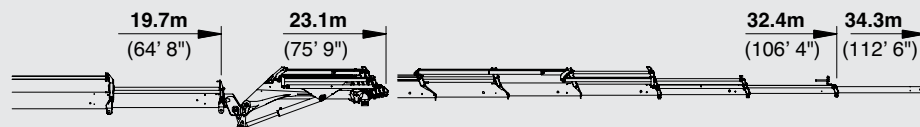
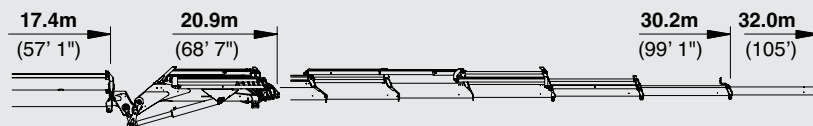
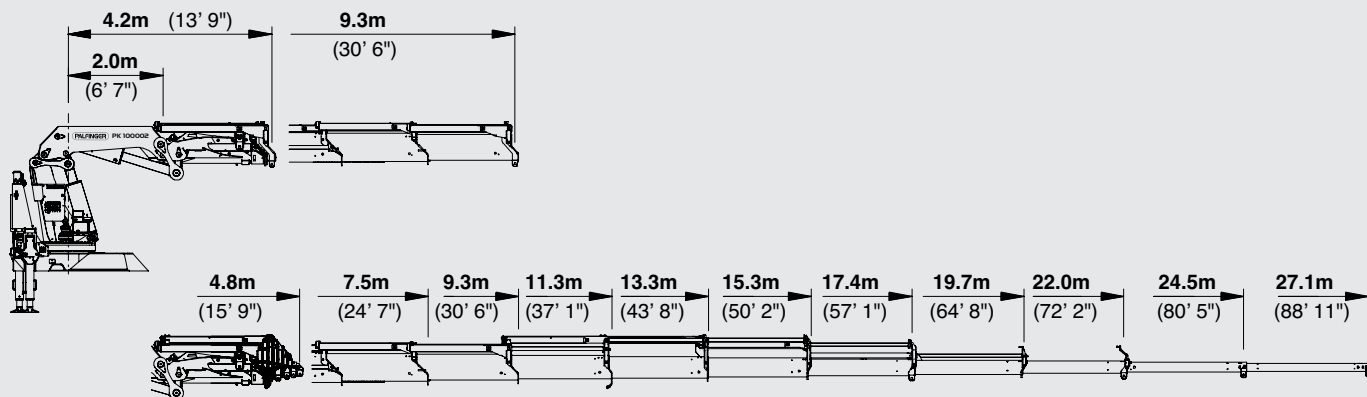

DIMENSIONS

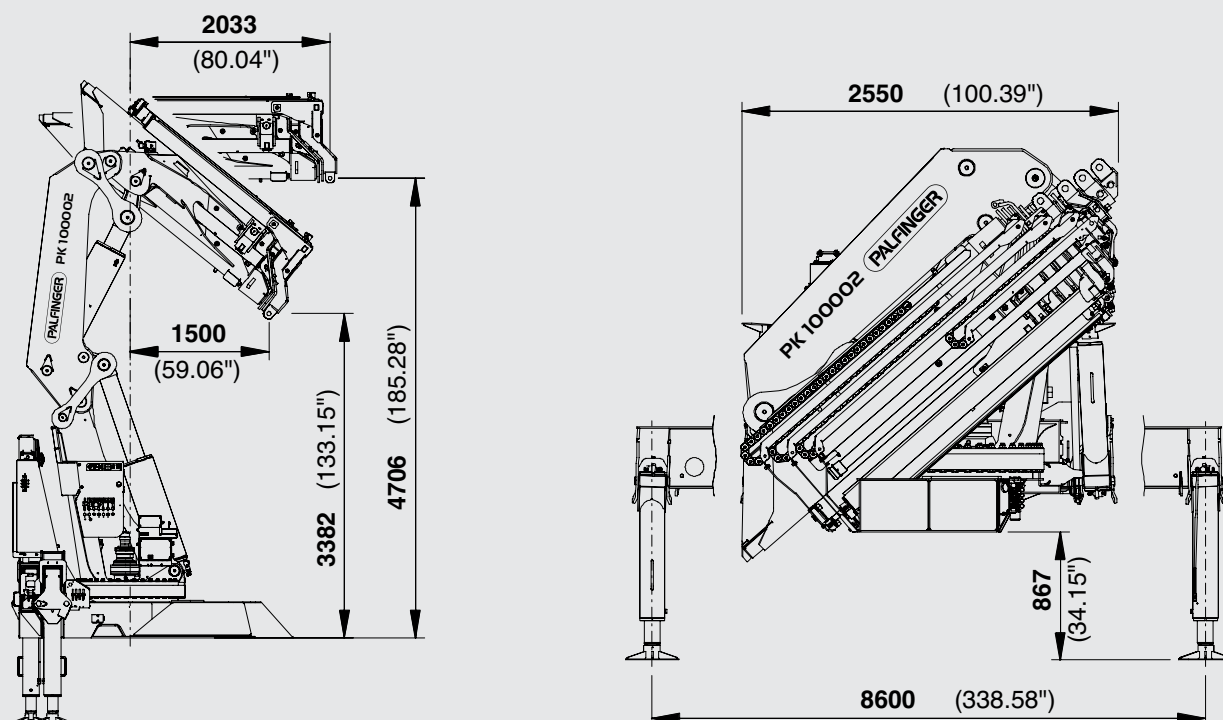

PK 100002

F PJ170E JV1

G PJ125E JV1

TECHNICAL SPECIFICATIONS (EN 12999 HC1 HD4/B3)

Max. lifting moment	92.2 mt/904.5 kNm	666870 ft.lbs
Max. lifting capacity	30000 kg/294.3 kN	66140 lbs
Max. hydraulic outreach	22.0 m	72' 2"
Max. manual outreach	27.1 m	88' 11"
Max. outreach (with fly-jib)	32.0 m	104' 12"
Slewing angle	continuously variable	
Slewing torque	9.0 mt/88.3 kNm	65100 ft.lbs
Stabiliser spread (std.)	8.6 m	28' 3"
Fitting space required (std.)	2.31 m / 2.47 m	7' 7" / 8' 1"
Width folded	2.55 m	8' 4"
Max. operating pressure	365 bar	5293 psi
Recommended pump capacity	from 90 l/min	23.8 US gal./min
	to 110 l/min	29.1 US gal./min
Dead weight (std.)	8800 kg	19400 lbs

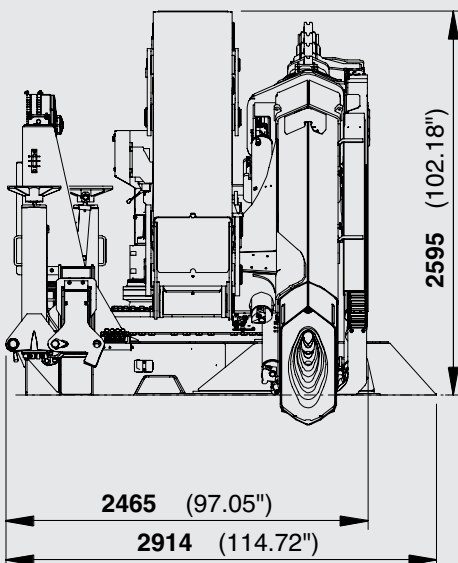



Cranes shown in the leaflet are partially optional equipped and do not always correspond to the standard version. Country-specific regulations must be observed. Dimensions may vary. Subject to technical changes, errors and translation mistakes.