

CLARK

475 C

MICHIGAN

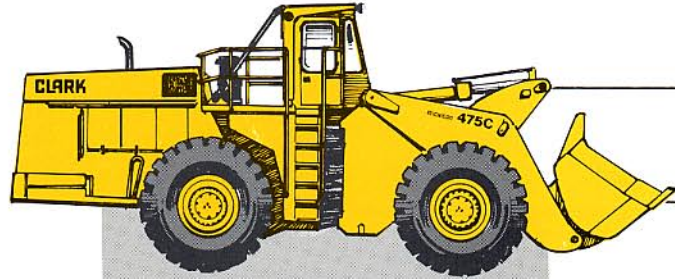



ENGINE

		Detroit
Make	Cummins	Diesel
Model	VTA-1710C	16V-92N80
Maximum hp (kW)*	700 (522)	702 (524)
Flywheel hp (kW)**	630 (470)	632 (471)
Governed rpm	2000	2000
Maximum torque, lbf • ft	2175 @ 1500	1966 @ 1400
N • m	2947 @ 1500	2664 @ 1400
Bore and stroke, in	5.50 x 6.00	4.84 x 5.00
mm	139,7 x 152,4	123,0 x 127,0
Number of cylinders	12	16
Displacement, in ³	1710	1472
L	28,0	24,1
Electrical system (alt.)	24V, 100A	24V, 100A

*Maximum horsepower of basic engine under SAE standard J816—barometric pressure of 29.38 in Hg (74,62 cm Hg), 85°F (29,4°C) and maximum engine speed with fuel pump, water pump and lubricating oil pump.

**Net usable horsepower at engine flywheel under SAE standard J816—barometric pressure of 29.38 in Hg (74,62 cm Hg), 85°F (29,4°C) and governed engine speed with fan, alternator and air cleaner.



DRIVETRAIN

TORQUE CONVERTER: Clark industrial type, single-stage; 2.96:1 torque multiplication ratio.

TRANSMISSION: Clark countershaft type powershift with directional clutch modulation; four speeds forward, four speeds reverse.

Travel Speeds:*	1st	2nd	3rd	4th
mph	3.7	6.4	10.9	18.6
km/h	6,0	10,3	17,5	29,9

*Measured with 41.25/70-39, 34PR (L-5) tires.

DIFFERENTIAL: Clark limited slip, front and rear.

AXLES: Heavy-duty Clark planetary design with single-piece cast steel housing. Front axle fixed, rear axle oscillates a total of 20°. Vertical wheel travel of 20.0 in (508 mm) with all wheels remaining on ground.

PLANETARY DRIVES: Clark low-friction, roller bearing planetary in each wheel.



STEERING SYSTEM

Articulated frame with full hydraulic power steering.

ANGLE OF STEER: Each direction 35°; total 70°.

DEMAND VALVE: Provides constant volume of oil to the steer valve for positive steering control at all engine rpm.

PUMP: Gear-type design, torque converter mounted. Output is 82.0 U.S. gpm (310 L/min) @ 2000 rpm and 1000 psi (6894 kPa).

RELIEF PRESSURE: 2500 psi (17 236 kPa).

CYLINDERS: Two double-acting with chrome plated piston rods. Bore and stroke—6.00 x 23.80 in (152,4 x 604,5 mm).



BRAKES (SAE J1152) (ISO 3450)

SERVICE: Four wheel dry disc type; 29.0 in (737 mm) dia. x 1.25 in (31,8 mm); two calipers per wheel, hydraulic actuation. Application of left pedal also neutralizes transmission in FORWARD only.

SECONDARY: System split axle-by-axle; manually actuated by service brake pedal; audible and visible alarms; dead-engine braking capability provided by two (2) accumulators pre-charged with nitrogen.

PARKING: Dry disc type; 20.0 in (508 mm) dia. x 0.50 in (12,7 mm); mounted to front axle input shaft; spring-on, hydraulic-off with dash-mounted hand valve actuation; transmission interlock applies service brakes to prevent moving machine when parking brake is applied.

PUMP: Piston; pressure compensated; 3000 psi (20 684 kPa).

FILTER: Full flow; 10 micron.



TIRES

Tubeless, nylon body, extra deep tread rock 41.25/70-39, 34PR (L-5)**.

Other tires available: 37.5-39, 36PR (L-5)*

*Use of tire chains on rear axle not recommended.

37.5-39, XRD2A★Radial**

41.25/70-39, 42PR (L-5)**

**Use of tire chains requires oscillation stops on rear axle.



HYDRAULIC SYSTEM

Closed and pressurized with a capacity of 248.0 U.S. gal (938,8 L); oil supplied from sturdy plate steel reservoir. Access hole in tank for easy cleaning; in-tank magnets provide extra protection.

BOOM CONTROLS: Valve has four positions: raise, hold, lower, float. Automatic electric/magnetic kickout adjustable for any position between maximum boom reach and full lift height.

BUCKET CONTROLS: Valve has three positions; rollback, hold, dump. Automatic electric/magnetic bucket positioner adjustable to any desired loading angle.

PUMPS: Three, gear-type design, torque converter mounted. Total output is 231.0 U.S. gpm (874 L/min)—two pumps each rated 82.0 U.S. gpm (310 L/min) @ 2000 rpm and 1000 psi (6894 kPa); one pump rated 67.0 U.S. gpm (254 L/min) @ 2000 rpm and 1000 psi (6894 kPa).

VALVE: Split spool with built-in pressure relief valve; actuated by remote mounted pilot valve. Mounted on front frame for easy access.

RELIEF PRESSURE: 2700 psi (18 615 kPa).

CYLINDERS: Two boom and two bucket, all double-acting. Boom, bore & stroke—10.50 x 58.38 in (266,7 x 1482,9 mm). Bucket, bore & stroke—9.00 x 33.38 in (228,6 x 847,9 mm).

FILTERS: Full-flow 10 micron return filter (4 elements), in reservoir.



HYDRAULIC SPEEDS

Raising time (with load)	12.0 s
Dumping time (with load)	3.7 s
Lowering time (empty)	6.3 s
Total cycle	22.0 s

OPERATING DATA with 41.25/70-39, 34PR (L-5) tires

Data below conforms to applicable standards J732 and J742 recommended by the Society of Automotive Engineers for wheel loaders. Change in standard configuration may change machine dimensions or operating data. Refer to Supplemental Operating Data.

Bucket Type	LONG BOOM		
	Straight Edge Rock	Spade Nose Rock	
Capacity, Rated (heaped)	yd ³ m ³	12 9,18	12 9,18
Rated (struck)	yd ³ m ³	9.84 7,52	10.22 7,81
Cutting Edge Width	in mm	176.2 4475	176.2 4475
Dump Height @ Full Lift and 45° Discharge Angle*	ft mm	15'5" 4699	14'10" 4521
Reach @ Full Lift and 45° Discharge Angle*	ft mm	5'11" 1803	6'6" 1981
Reach @ 45° Discharge Angle and 7 ft (2130 mm) Height*	ft mm	9'10" 2997	10'5" 3175
Overall Length	ft mm	40'10" 12 446	41'8" 12 700
Overall Operating Height*	ft mm	28'9" 8763	28'9" 8763
Clearance Circle (bucket in carry position)	ft mm	68'6" 20 879	68'6" 20 879
Breakout Force	lbf kN	95 640 425,4	92 360 410,8
Static Tipping Load, Straight	lb kg	101 550 46 063	101 730 46 145
Full (35°) Turn	lb kg	91 520 41 513	90 790 41 182
Operating Weight** Total	lb kg	167 760 76 096	168 320 76 350

475C Wheel Loader

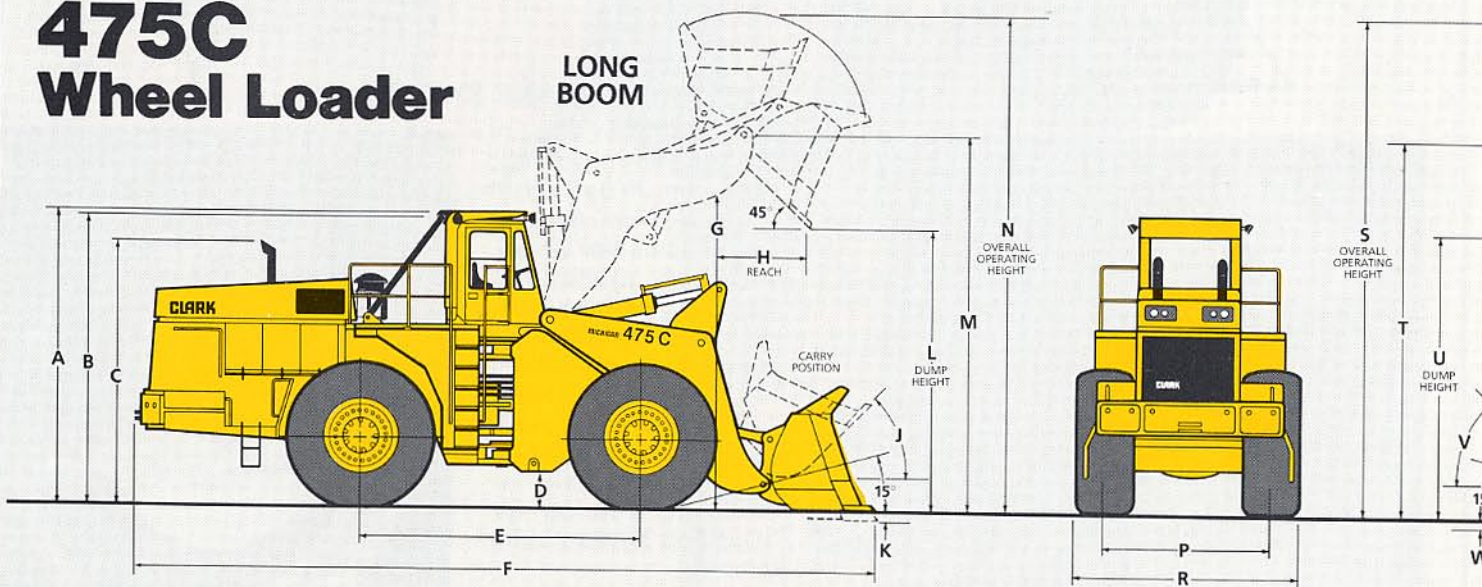

MACHINE DIMENSIONS*

Tire Size	A	B	C	D	E	F	G	H▲	J	K	L▼	M	N	P	R	S
41.25/70-39 (L-5)	16'0" mm 4877	15'4" 4674	14'0" 4267	1'11" 584	15'2" 4623	†	16'11" 5156	‡	40°	3.0" 76,2	‡	20'7" 6274	‡	9'11" 3023	13'6" 4115	‡
37.5-39 (L-5)	16'2" mm 4928	15'6" 4724	14'2" 4318	2'1" 635	15'2" 4623	‡	17'1" 5207	‡	40°	1.0" 25,4	‡	20'9" 6325	‡	9'11" 3023	13'2.3" 4021	‡
37.5-39 XRD2A* Radial	16'0" mm 4877	15'4" 4674	14'0" 4267	1'11" 584	15'2" 4623	‡	16'11" 5156	‡	40°	3.0" 76,2	‡	20'7" 6274	‡	9'11" 3023	13'3" 4039	‡

*See Operating Data. ▼Deduct 10.3 in (261,6 mm) when bucket teeth used. ▲Add 10.3 in (261,6 mm) when bucket teeth used.

STANDARD BOOM

Straight Edge Rock	Spade Nose Rock
12 9,18	12 9,18
9.84 7,52	10.22 7,81
176.2 4475	176.2 4475
14'3" 4343	13'8" 4166
5'11" 1803	6'6" 1981
9'2" 2794	9'9" 2972
39'8" 12 090	40'6" 12 344
27'6" 8382	27'6" 8382
67'6" 20 574	67'6" 20 574
104 060 462,9	101 760 452,7
109 600 49 715	109 030 49 456
99 070 44 938	98 560 44 707
165 760 75 189	166 320 75 443

STANDARD BOOM

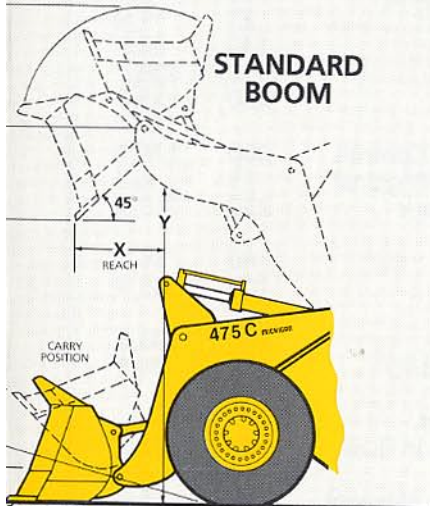

T	U▼	V	W	X▲	Y
19'5" 5918	÷	42°	3.5" 89	÷	16'3" 4953
19'7" 5969	÷	42°	1.5" 38	÷	16'5" 5004
19'5" 5918	÷	42°	3.5" 89	÷	16'3" 4953

SUPPLEMENTAL OPERATING DATA

*Dimensions: change with tires other than 41.25/70-39, 34PR(L-5); add (or subtract) as applicable.

	37.5-39, 36PR	37.5-39 Radial
VERTICAL	2.0 in (50,8 mm)	0
HORIZONTAL	-1.2 in (30,5 mm)	-0.25 in (-6,35 mm)

**OPERATING WEIGHT: Is approximate and includes bucket shown, cab, ROPS canopy, and 3,936 lb (1785 kg) counterweight. Rear tire hydroinflation is not recommended. A change in tire size or the addition of either optional equipment or attachments will affect both operating weight and tipping load. Changes are shown below for selected items.

ITEM	CHANGE IN OPERATING WEIGHT		CHANGE IN FULL TURN STATIC TIPPING LOAD			
	lb	kg	LONG BOOM		STANDARD BOOM	
41.25/70-39, 34PR (L-5)	0	0	0	0	0	0
41.25/70-39, 42PR (L-5)	900	408	520	236	590	268
37.5-39, 36PR (L-5)	0	0	0	0	0	0
37.5-39, XRD2A★Radial	-2800	-1270	-1630	-739	-1820	-826
Bucket Teeth: Heavy Duty	850	386	-1060	-481	-1060	-481
Cab (removal)	-700	-318	-572	-259	-550	-249
Counterweight: four 3 in (76,2 mm) bumper plates	1384	628	2924	1326	3295	1495
Counterweight: eight 3 in (76,2 mm) bumper plates	2768	1256	5875	2665	6620	3003
ROPS Canopy (removal)	-2400	-1088	-1620	-735	-1620	-735

BOOM/TRUCK REFERENCE CHART

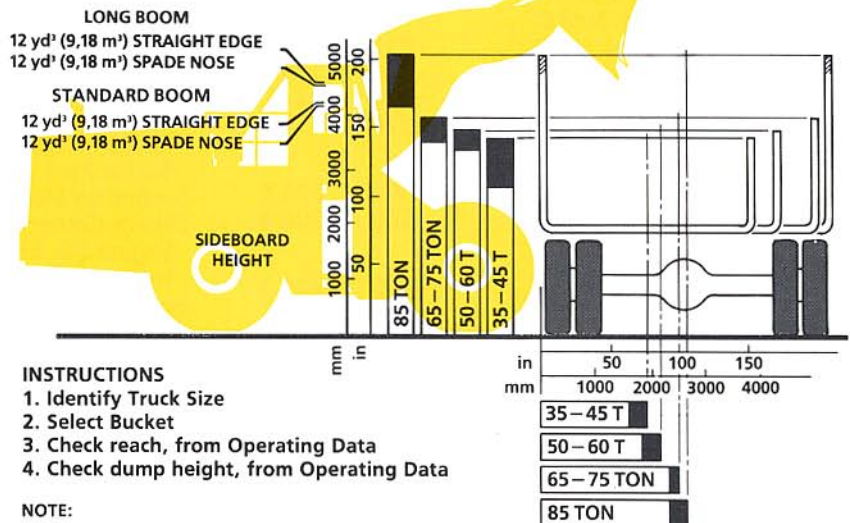

INSTRUCTIONS

1. Identify Truck Size
2. Select Bucket
3. Check reach, from Operating Data
4. Check dump height, from Operating Data

NOTE:

This chart is designed to provide you with a quick reference for selection of proper boom to match truck requirements. Be sure to check Operating Data for exact dimensions when making final selection.

DISTANCE TO CENTER OF TRUCK

Black area represents manufacturer variance

STANDARD EQUIPMENT

Alternator 100A	Safety Glass, Tinted	Lifting Lugs
Battery Disconnect, Lockable	Seat Belt (SAE J386)	Lights, Work (150W) 3 Front, 2 Side, 2 Rear
BOOMS	Seat, Suspension, 6-way Adjustable	Neutral Start Feature
Long or Standard	Steering Wheel Spinner Knob	Quick Connect Hydraulic Pressure Test Ports
Boom and Bucket Control Levers, Dash Mounted	Windshield Washer and Wiper; Front & Rear	Rearview Mirrors (2) Exterior
Boom Kickout, Automatic	Cold Start Aid, Ether	ROPS Canopy (SAE J1040) (ISO 3471)
Brakes; Hydraulic Disc 4-Wheel	Dead Engine Parking Brake Release	Sealed Pins
Brake System, Secondary	Differentials, Limited Slip, Front and Rear	Service Platforms
Bucket Leveler, Automatic	Drawbar With Pin	Tires: 41.25/70-39, 34PR (L-5) (Goodrich or General Brand)
Cab Access Steps and Handrails (SAE J185)	Hood Side Panels	VANDALISM LOCK,
CAB (NON-ROPS)	Hydraulic Oil Cooler; Oil to Air	Provisions For:
Acoustical Lining	INSTRUMENTS/GAUGES	Batteries
Doors, Lockable with Self-Locking Sliding Glass Windows	Air Cleaner Restriction Indicator	Engine Coolant
Door Hold Open Struts (2)	Engine Coolant Level Sight Glass	Engine Oil
Electrical System; 24V Circuit	Engine Coolant Temperature Gauge	Hydraulic Fluid
Breaker Protected, Prewired for Optional Accessories	Engine Oil Pressure Gauge	Transmission Fluid
Environmental Control; Heater/ Defroster/Pressurizer (45,000 BTU) With Three Speed Blower Fan, Filtered Air	Hourmeter	WARNING LIGHTS/AUDIBLE ALARMS
Floor Mats	Hydraulic Fluid Level Sight Glass	Brake Parking
Interior Lights, Red and White	Torque Converter Fluid Temperature Gauge	Brake Pump Differential Pressure
	Transmission Fluid Level Sight Glass	Brake System, Front
	Voltmeter	Brake System, Rear
		Horn
		Reverse Alarm (SAE J994)

OPTIONAL EQUIPMENT and approximate installed weights

BUCKETS

For Standard Boom: SAE Heaped Capacity Shown

	lb	kg
12 cu yd Spade Nose, Rock	13,900	6305,0
12 cu yd Straight Edge, Rock	13,400	6078,2

For Long Boom: SAE Heaped Capacity Shown

12 cu yd Spade Nose, Rock	14,000	6350,4
12 cu yd Straight Edge, Rock	13,500	6123,6

BUCKET TEETH AND WEAR CAPS

Teeth (8) Spade Nose Bucket, Weld-On Flush Leg Shank	800	362,9
Teeth (8) Spade Nose Bucket, Weld-On 1 1/2 Leg Shank	850	385,6
Teeth (8) Straight Edge Bucket, Weld-On Flush Leg Shank	850	385,6
Teeth (8) Straight Edge Bucket, Weld-On 1 1/2 Leg Shank	850	385,6
Rock Points, Standard	230	104,3
Rock Points, Heavy Abrasion	280	127,0
Rock Points, Flush Cut Point, Clean-Up	270	122,4

CUTTING EDGE WEAR CAPS

Spade Nose Bucket	500	226,8
Straight Edge Bucket	500	226,8

TIRE OPTIONS

37.5-39, 36PR (L-5)	18,700	8482,3
37.5-39, XRD2A★	19,600	8890,5
41.25/70-39, 42PR (L-5)	15,900	7212,2

CAB AND ROPS CANOPY RELATED OPTIONS

Air Conditioner (21,500 BTU)	150	68,0
Lights, Work (2) 150 W Hood Mounted, Side/Rear	20	9,1

SERVICE CAPACITIES

	U.S. gal	litres
Axle Differentials, front & rear	29.0	109,8
Cooling System (Cummins)	60.0	227,1
Cooling System (Detroit Diesel)	68.0	257,4
Crankcase (Cummins)	27.0	102,2
Crankcase (Detroit Diesel)	16.0	60,6

GENERAL OPTIONAL EQUIPMENT	lb	kg
Cold Starting Aid, Engine Water and Oil Preheater, 220V	10	4,5
Counterweight Kit (four 3" Plates)	1,384	627,8
Counterweight Kit (eight 3" Plates)	2,768	1255,6
Coupler, Fast Fuel (Wiggins)	25	11,3
Engine Oil Evacuation (Wiggins)	15	6,8
Engine Shutdown to Idle Kit	25	11,3
Fan, Sucker	140	63,5
Fenders, Front	900	408,2
Fire Suppression Kit	250	113,4
Hydraulic Control Kit — 3-Spool Valve, Piping, and Controls	300	136,1
Hydraulic Fluid Evacuation (Wiggins)	15	6,8
Lubrication System, Automatic	250	113,4
Lubrication System, Single Point, Manual	80	36,2
Radiator Sand Grid	100	45,4
Radiator Shutters (Includes Sucker Fan)	240	108,8
Secondary Steering Kit (Electric)	120	54,4
Service Center (Wiggins)		
Engine Oil, Engine Coolant, Hydraulic Fluid, Transmission Fluid	60	27,2
Sun Visor	10	4,5
Transmission Fluid Evacuation (Wiggins)	30	13,6
Warning System A.I.D. High Water Temperature, Low Oil Pressure	15	6,8

	U.S. gal	litres
Fuel Tank	273.0	1033,4
Hydraulic Reservoir	150.0	567,8
Propshaft Mid-Mount	1.25	4,7
Torque Converter/Transmission	33.0	124,9
Wheel Hubs (each)	10.6	40,1

CLARK POWERSHIFT TRANSMISSION

For tough jobs that demand fast cycle times, the Clark powershift transmission features a rugged countershaft design and directional clutch modulation. Directional clutch modulation enables the operator to shift smoothly from forward to reverse—at full power—without using the brakes to stop the machine. This feature helps reduce operator fatigue and strain on the drivetrain.



LONG OR STANDARD BOOMS

The choice of booms permits customizing the machine for productivity. The long boom for jobs that require extra dump height and reach. The standard boom lifts hefty bucket loads of material with ease and also provides heavy-load stability for load and carry applications. Each boom is constructed from alloy steel with boom and bucket cylinders in-line for smooth, coordinated lifting action. Pivots are equipped with sealed pins with a 100 hr. lubrication interval, except bucket pins, 50 hr.

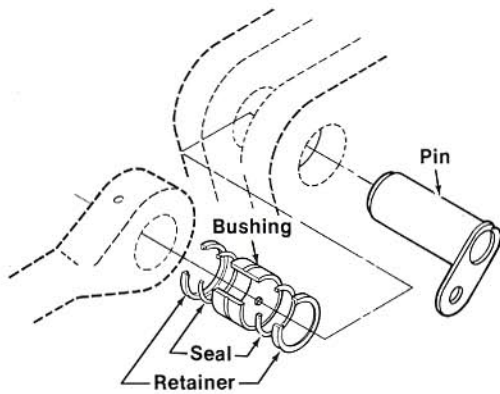

CLARK LIMITED SLIP DIFFERENTIALS

Standard in both the front and rear axles, the limited slip differentials proportion driving torque in all wheels to match the operating conditions. This arrangement provides the best available traction for varying conditions and ease in steering, while minimizing wheel spin.

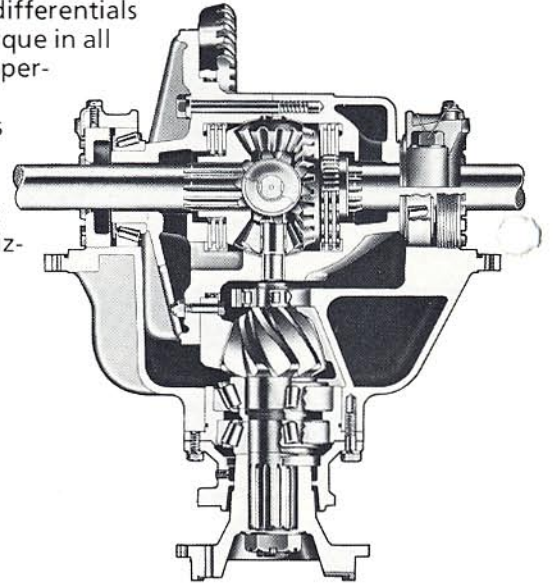

HYDRAULIC BRAKE SYSTEM

Service brakes are dry disc type with hydraulic actuation, 29.0 x 1.25 in. (737 x 31,8 mm) disc and two calipers per wheel. Secondary, axle-by-axle dead engine braking is provided by nitrogen charged accumulators. The 20.0 x .50 in. (508 x 1,27 mm) dry disc parking brake, mounted on the front axle input shaft, is spring applied and hydraulically released.

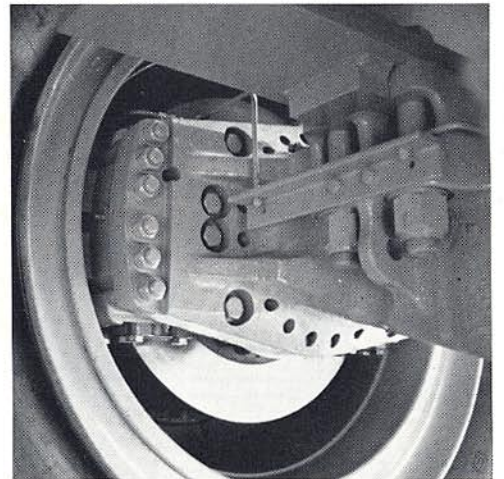

Specifications subject to change without notice or obligation.
Illustrations used in this publication include optional equipment.

WL475C OCT 83

R.C.S. STRASBOURG B 303 376 990

CLARK Construction
Machinery
Division